



Ethernet - serial interface e-ILPH

Ethernet – serial interface

e-ILPH

1. Description

This interface realizes conversion from TCP/IP connection to serial link.

The TCP/IP connection use RJ45 connector for 10/100 Base T link

The serial connection is provided with RS232 and R485 signals.

The interface is able to work in slave MODBUS/TCP protocol (server mode), direct connection (tunnel) in server or client mode, e-ILPH is also able to send mail via SMTP protocol using simple HAYES command on the serial line.

Isolation: Serial lines (RS232 and RS485) uses common potential but are isolated from power supply and network connection. Isolation is 1500V from network connection to power supply and serial lines. The voltage isolation is 750 V from power supply and serial lines.

2. Connection

2.1. Power supply

Power supply use standard, removable, 5.08 mm size connector with ground connection. The voltage might be from 10 V AC/DC to 24V AC/DC. The consumption is less then 2 Watt.

The following figure shows the power supply connection:

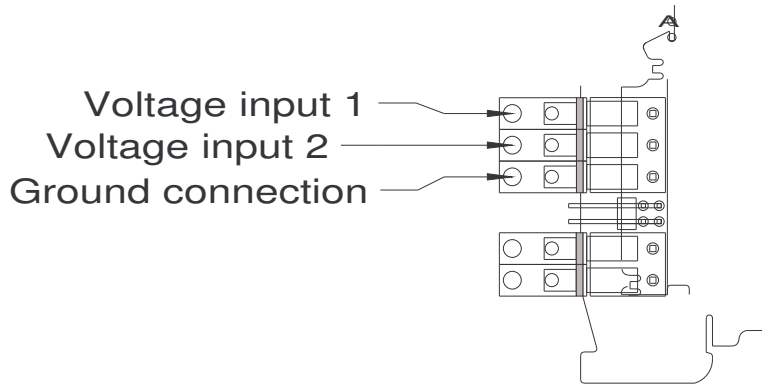

Ground connections are also available with screw connection on the same side of e-ILPH, this connection uses A and B connector as shown on the following figure:

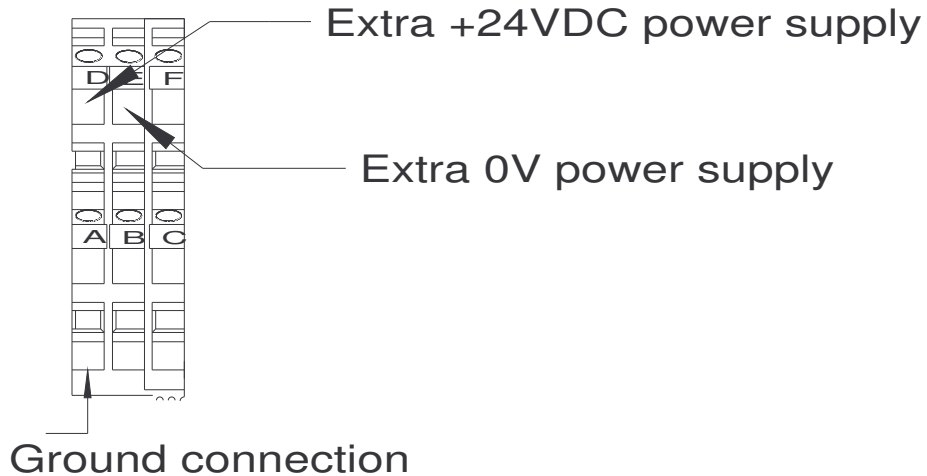

Additional connector allowed extra power supply for redundant power management

Ethernet – serial interface

e-ILPH

2.2. Network

Network connection is realized through standard RJ45 CAT5 cable, the connection could be realized when product is under power.

The speed of connection is automatically chosen between 10 or 100 mb depending on network possibilities.

2.3. Serial port

RS485 connection:

This connection uses two plug of removable 5.08 mm size connector, the following figure shows connection with indicated polarity

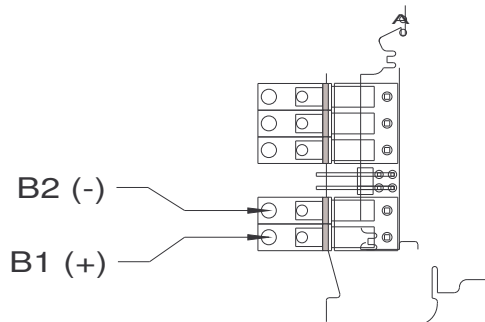

RS232 Connection:

The RS232 connection uses standard male DB9 connector. Only 3 wires of connector are used (TX, TX, GND), metallic part of connector is connected to ground. The wire configuration is the same as it is on P.C. that means this configuration:

TX: 3 RX: 2 GND: 5

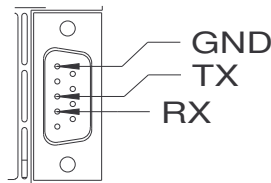

This configuration is able to replace any old serial PC connection with Ethernet connection using e-ILPH with the same cable used before. Example with AC31: Any CPU could be connected to the serial port of e-ILPH using standard 07SK50 cable

Additional connections of RS232 are available with screw connection on the same side of e-ILPH, those connections allows using any cable for connection compatibility. The configuration is shown in the following figure.

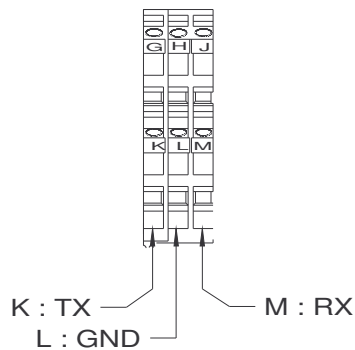

Ethernet – serial interface

e-ILPH

3. Configuration

Configuration menu or switch is used to defined parameter such as IP address, TCP port address and also serial parameters and working mode (tunnel, MODBUS/TCP)

3.1. Switch configuration

Configuration by switch is validated after a reset of the product, changes are effective only after power off and power on sequence

The switches are accessible by opening product on the left side as shown on the figure

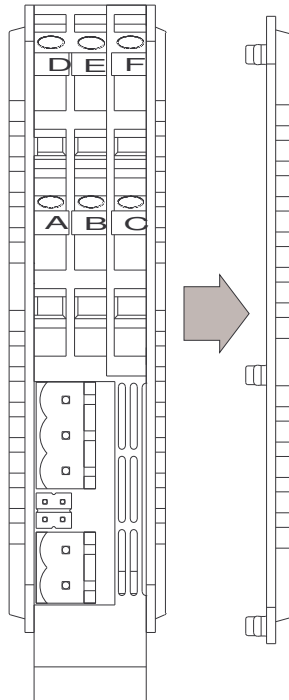

There are two groups of switches one with 4 switches, other one with 8 switches. First one (SWITCH A) is reserved for hardware configuration of RS485. Second one (SWITCH B) is used for serial parameter and main working possibilities. Following figure show location of switches:

Ethernet – serial interface e-ILPH

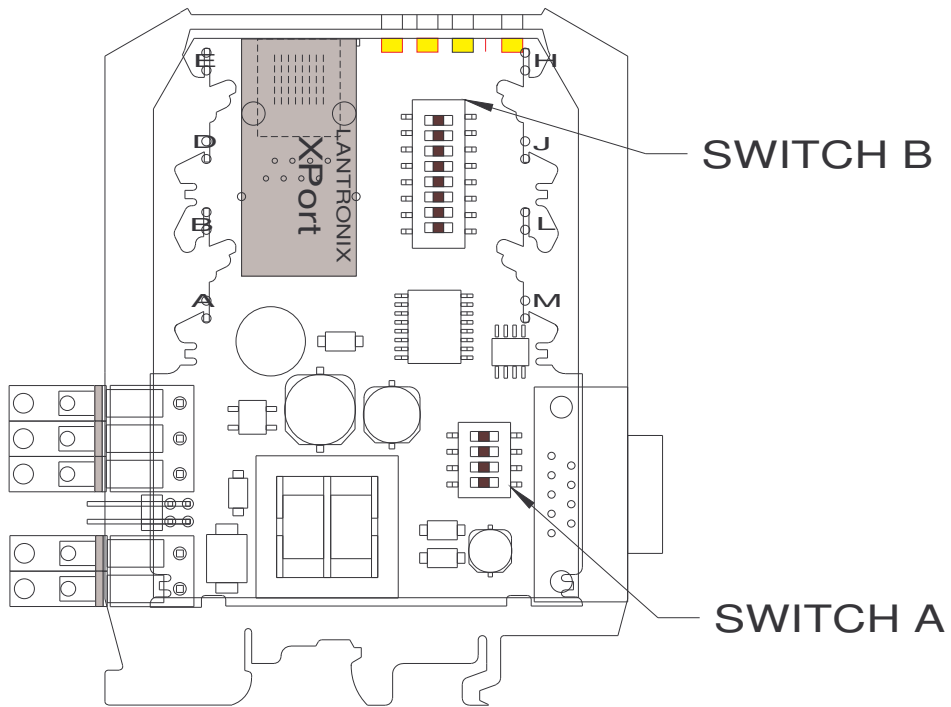

SWITCH A:

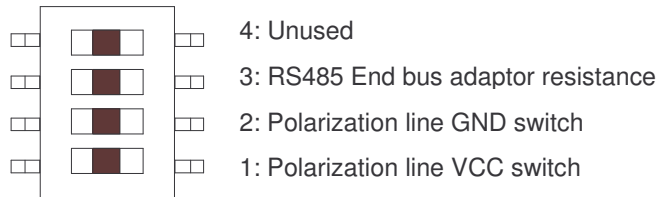

The on position is on the left side of the switch (keeping orientation of the previous figure)

Switch 1 and 2 might be in the same position, they are used to set polarization on RS485 lines, when these switch are set to the on position the line is polarized.

Switch 3 connect RS485 line to 120Ω resistor, this is done to realize adaptation line on the end of the bus. The connection is done when switch is set to the on position. The following diagram shows connections

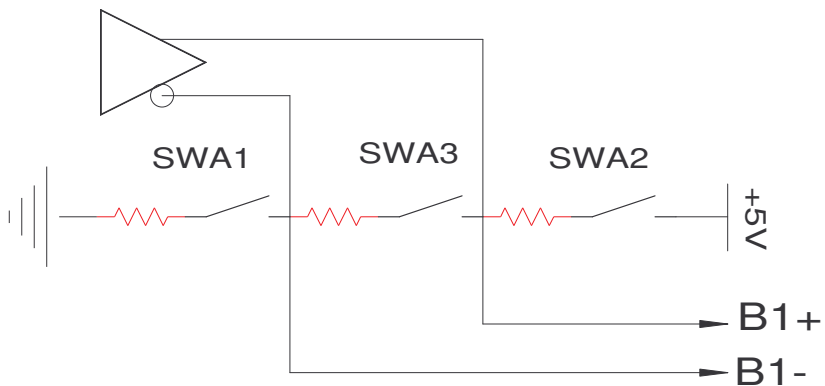

Ethernet – serial interface

e-ILPH

SWITCH B:

9600	38400	57600	115200
<input type="checkbox"/> OFF 8 <input type="checkbox"/> OFF 7	<input type="checkbox"/> OFF 8 <input type="checkbox"/> ON 7	<input type="checkbox"/> ON 8 <input type="checkbox"/> OFF 7	<input type="checkbox"/> ON 8 <input type="checkbox"/> ON 7
ON	Functionality	OFF	
Even parity	<input type="checkbox"/> 6	Odd parity	
No parity	<input type="checkbox"/> 5	Parity	
1 Stop bit	<input type="checkbox"/> 4	2 Stop bit	
AC31 mode enable	<input type="checkbox"/> 3	Disable	
Modbus slave	<input type="checkbox"/> 2	Transparent mode	
Soft config enable	<input type="checkbox"/> 1	Switch enable	

1: Selection Soft / switch configuration, when this switch is set to on position the switch configuration is ignored, configuration is fully made with software. When set to the off position, switch configuration are valid. All parameter defined in the following switch can't be modified by software

2: Selection tunnel or MODBUS mode, when the switch 1 is off position, the e-ILPH always works as server mode. The switch 2 gives the possibilities of choosing if the working mode will be Tunnel mode (transparent mode) or MODBUS/TCP slave mode. When switch n°2 is set to the off position Tunnel mode (transparent mode) will be selected. Otherwise, e-ILPH works as MODBUS slave mode.

3: Selection AC31 program mode, this switch select, when set to the on position, particular working mode to switch automatically from MODBUS TCP to direct mode automatically. This particular working mode is used give the possibility of downloading program through the Ethernet connection. See chapter 8.

4: Stop bits selection, when this switch is set to the on position the serial format use one stop bit, use two stop bit otherwise.

5: Parity / No parity selection, when this switch is set to on position the serial frame include no parity. When this switch is set to the off position the parity is determine by position of switch 6.

6: Even or Odd parity, the switch select even or odd parity when the switch 5 is set to the on position. When is set to the on position even parity is selected.

7: Speed configuration 1

8: Speed configuration 2

Theses switches select serial speed from 4 values according the following table:

Switch 7	Switch 8	Speed selected
Off	Off	9600
On	Off	38400
Off	On	57600
On	On	115200

Ethernet – serial interface

e-ILPH

3.2. Software configuration

Software configuration is accessible using network or serial link. In both case the configuration menu is the same.

Connecting to configuration menu with network connection

To connect to the e-ILPH use TELNET software, TELNET is a terminal mode under network connection; this software is always included in windows software package. The command to invoke TELNET is the following (under DOS command windows):

```
TELNET <IP> <port>
```

Where <IP> is the IP address in decimal mode separate by dot. Example 10.33.152.77

<port> is the TCP port used for connection, the default standard is 23, this is not necessary to add this value in the command. For example connecting to brand new e-ILPH (with default values coming from factory production):

```
TELNET 10.33.152.76
```

On some recent windows package (WIN2000) hyper terminal mode gives the possibility of network connection using Win sock instead of COMx connection. This software could be use to configure e-ILPH (in this case TCP channel might be set to 23)

Connecting to configuration menu using RS232 serial connection

Configuring e-ILPH is possible through R232 serial port connection. This possibility is particularly interesting because there is no need to know the IP address affected to the product. To realize this configuration do the following:

Switch off the e-ILPH

Connect it to the serial line of PC with cross cable.

Open terminal mode (hyper terminal or other), configure link with parameter 9600 bauds, 8 bits, no parity, 1 stop bit, no flow control. In this mode the serial configuration does not depend on switch or software configuration and will be always the same.

To enter in setup mode hold down the x key then switch on the e-ILPH. By detecting xxx sequence the e-ILPH enters in setup mode, and then the configuration process is the same and independent of connection type.

Entering in setup menu

Immediately after connection e-ILPH display a first interface that give possibility to select setup or monitor mode. The monitor mode is an advanced menu that allows getting and writing data from and to the setup memory. This way is expert mode and not easy for human understanding. This mode will be described in other specific document.

The first configuration menu wait few second for pressing enter key to switch to setup menu, some interesting information are displayed. See in the following line some example of this display :

```
***** ABB ----- e-ILPH *****
```

MAC address 00204A8254AF

Software version 01.1 (050118) V3 550_XPTEX

Press Enter to go into Setup Mode

MAC address is unique hardware address of each e-ILPH,

In the second line software version is displayed (with date inside of parenthesis) followed by library version number.

After pressing key ENTER the display goes to setup menu mode as following lines shows:

```
***** ABB ----- e-ILPH *****
```

Ethernet – serial interface

e-ILPH

***** Network parameters *****

Hardware: Ethernet ILPH TPI
IP Address : 10.33.152.76, no gateway set
e-ILPH is in slave MODBUS/TCP mode
Netmask: 255.255.252.000

***** Serial communication port *****

Baudrate 57600 Bauds
8 Bits, No parity, 1 Stop bit, No flow control

***** Configuration menu *****

- 0: Network configuration**
- 1: Serial line parameter**
- 2: Operation mode**
- 3: Factory defaults**
- 4: Exit without save**
- 5: Save and exit**
- 6: English/Francais**

First part displays actual configuration values, with current IP address, current working mode (in the example (e-ILPH is in slave MODBUS/TCP) and serial lines parameter.

Then it is printed the menu choice with number and the corresponding choice:

Menu description

0 Network configurations

This menu is configured network information; please ask to your local network manager before setting values.

Enter this menu by pressing 0 + enter key. E-ILPH asks you for IP address, the current value of each byte is displayed in parenthesis, if you don't want to change the byte value just press enter or dot key. The following byte will be asked, if modification is necessary just enter new value in decimal mode followed by enter or dot key.

After setting IP address display asks you if you need to set gateway address, each time this kind of request is displayed the current value is displayed in parenthesis, if no modification just press enter key. If you want to modify press Y, the answer is not case sensitive, y is also accepted.

Changing gateway IP address use the same process then setting IP address.

In this menu you are also able to change netmask, or TELNET password

Enter netmask is following the same procedure than entering IP address.

1 Serial line parameters

This menu is used to determine serial link parameter. Some parameters are not accessible is the switch 1 is set to the on position (see chapter on switch configuration) . For each parameter, actual value is shown in parenthesis. If no modification needed, just press enter.

Setting baudrate: enter desired baudrate value from the following list

300, 600, 1200, 2400, 4800, 9600, 19200, 38400, 57600, 115200

if no modification from the actual value, just press enter key, this setting is not accessible if switch 1 is on

Ethernet – serial interface

e-ILPH

Setting character size: input character size (7 or 8 bits), this value is not accessible is switch 1 is on

Input parity (0, 1, 2): 0 : no parity, 1 : Odd parity, 2 : Even parity, this value is not accessible is switch 1 is on

Input number of stop bit (1 or 2). This value is not accessible is switch 1 is on

Input flow control: 0 no flow control, 1 XON/XOFF control

2 Operation mode

This menu is used to select the working mode from the following menu that is displayed after:

e-ILPH is in slave MODBUS/TCP mode

0 : slave MODBUS/TCP mode

1 : transparent server mode

2 : transparent client mode

3 : MAIL mode

Each selected menu generates display of new menu with parameter required for the selected operation, on the first line is indicated the current operation mode. If no modification are required just press enter.

If 0 is press – Slave MODBUS/TCP mode is selected

The following menu asks for:

Source port: This is the TCP channel used for MODBUS/TCP communication. Usually the value is 502, but this value could be change (from 1 to 65536, except 23 that is reserved for TELNET configuration) to be in accordance with the configuration of the master.

Slave Timeout: This the timeout value, expressed in ms, before waiting the answer from the slave. This value is specifically used when there is two masters. This time is counted, in case of no response, before sending the request of the second master.

Enable automatic switch MODBUS-DIRECT mode <Y>: This parameter enable function of automatic switch mode from MODBUS/TCP to transparent mode. See chapter 8. If the parameter is Y (Yes) the following parameter line is displayed, otherwise the following parameter is not necessary.

Communication port on AC31 PLC (1) : Enter the communication port which is used to connect to AC31. 1 is the programming port, 2 is the CS31 port.

If 1 is press – transparent server mode is selected

The following menu asks for:

Source port: This is the TCP channel (from 1 to 65536, except 23 that is reserved for TELNET configuration) used to communicate in transparent mode.

1st ASCII code for pack data (0): This is the ASCII code that is check for Ethernet sending decision. The e-ILPH gives possibility of grouping character before sending frame to Ethernet. One or two characters can be defined. The main example is to send frame when Carriage return followed by line feed need to be detected to send frame to Ethernet. If both 1st and 2nd character are set to 0 Ethernet frame is generated for each received character.

2nd ASCII code for pack data (0): second ASCII code for pack decision.

If 2 is press – transparent client mode is selected

The following menu asks for:

SMTP server IP address: Enter the server IP address, uses the same procedure then entering own IP address.

Destination Port : Enter server destination port (from 1 to 65536)

Ethernet – serial interface

e-ILPH

Connection with HAYES command <Y>: Enter HAYES mode command is used for connection. If N (No) is answered, the following menu lines asks for characters (1 or 2) that are needed for connection

1st ASCII code for connection command (13): 1st character for connection decision

2nd ASCII code for connection command (0): 2nd character for connection decision. The procedure is the same then for packing decision. If both parameters are set to 0, connection is generated with any character.

1st ASCII code for pack data (0): this character is used for packing decision (generate Ethernet frame) when connection is established. The procedure is the same than in server mode.

2nd ASCII code for pack data (0): second character for pack decision, according to the same procedure than in server mode

If 3 is press – mail mode is selected

In this mode e-ILPH is able to send simple and limited text mail to two different receivers with a simple text command.

The following menu asks for:

SMTP server IP address: enter the SMTP server IP address (procedure is the same than entering own IP address)

TCP port for mail server: Enter the TCP port for mail server, default value is 25, this value could be modified to be in accordance with specific SMTP server

Mail recipient 1 :(mail1@fr.abb.com): Mail recipient 1: Enter (with limit of 48 characters) mail addresses of first mail recipient. To delete the value just press space bar and enter key. If no modification, press enter

Mail recipient 2 :(mail2@fr.abb.com): Enter (with limit of 48 characters) mail addresses of second mail recipient. To delete the value just press space bar and enter key. If no modification, press enter.

Domain name (e-ILPH.com): Enter (with limit of 23 characters) the domain name of e-ILPH (sender of message) .To delete the value just press space bar and enter key. If no modification, press enter.

Unit name (e-ILPH): Enter (with limit of 23 characters) the unit name of e-ILPH (sender of message). The mail sender address will be generated by addition of Domain name and unit name separate by @ such as UnitName@ DomainName. To delete the value just press space bar and enter key. If no modification, press enter.

Message 1 (This is the subject): Enter (with limit of 23 characters) the subject of the message. To delete the value just press space bar and enter key. If no modification, press enter.

Message 2 (This is first line): Enter (with limit of 23 characters) the first line of the message. To delete the value just press space bar and enter key. If no modification, press enter.

Message 3 (This is second line): Enter (with limit of 23 characters) the second line of the message. To delete the value just press space bar and enter key. If no modification, press enter.

Connection with HAYES command <N>: Enter HAYES mode command is used for connection. If N (No) is answered, the following menu lines asks for characters (1 or 2) that are needed for connection

1st ASCII code for connection command (13): 1st character for connection decision, the connection, if successful will automatically send mail

2nd ASCII code for connection command (0): 2nd character for connection decision. The procedure is the same then for packing decision. If both parameters are set to 0, connection is generated with any character.

Ethernet – serial interface

e-ILPH

3 Factory defaults

This menu, after confirmation by pressing key (depending on selected language, Y = Yes in English) set all parameters into factory default according the following list:

Name	Value	Description
Speed	9600	Speed of serial line, valid if switch configuration is inactive
Size	8	Size of serial line character
Parity	No	No parity in the character frame, valid if switch configuration is inactive
Stop bit	1	One stop bit in the frame, valid if switch configuration is inactive
Flow control	0	No flow control
AC31 Com port	1	Default value is connection on com1 for automatic protocol switch management (programming com port)
MODBUS	Yes	e-ILPH is in server configuration mode with MODBUS/TCP protocol
Source port	502	Default value for MODBUS/TCP protocol
Remote port	25	Remote destination port in client mode
CarCon1	13	Character trigger 1 for connection (default value is carriage return)
CarCon2	0	Character trigger 2 for connection, only one character will be check
CarPack1	0	Character 1 for pack decision (TCP frame will be created on each character received on serial line)
CarPack1	0	Character 0 for pack decision, (TCP frame will be created on each character received on serial line)
SMTP Port	25	Port number of remote mail SMTP server
Recipient1	mail1@fr.abb.com	First mail recipient for automatic mail transfer
Recipient2	mail2@fr.abb.com	Second mail recipient for automatic mail transfer
Domain	e-ILPH.com	Default domain name of sender
Unit	e-ILPH	Default mail address sender will be e-ILPH@e-ILPH.com
Subject	This is the subject	Subject of the mail
First line	This is first line	First line in the text of mail
Second line	This is second line	Second line in the text of mail

All IP addresses will be kept as previously defined

4 Exit without save

5 Save and exit

All the previous parameters are during configuration stored in volatile memory.

To cancel all modifications chose menu 4.

To valid all modifications chose menu 5, after store done e-ILPH will be reset automatically, if connections are still active, they will be cancel

6 English/Francais

This menu allows you to change configuration menu language; the value will be kept in non-volatile memory for the next connexion.

Ethernet – serial interface

e-ILPH

4. Hayes commands

Hayes commands are used in Mail mode; there is command for configuration, display values and command for connection. All commands are not case sensitive

Configuration command:

ATM1 or **ATM2**: Set mail recipient 1 and 2, followed by 48 characters max. if command is send alone (with no following characters) the mail recipient will be deleted

ATMU: set unit name, followed by 23 characters max. if command is send alone (with no following characters) the unit name will be deleted

ATMD: set domain name followed by 23 characters max. if command is send alone (with no following characters) the domain name will be deleted.

ATMS1, **ATMS2**, and **ATMS3**: set message 1, 2 or 3, message 1 is the subject of mail, others are lines of body. Limited to 23 characters. if command is send alone (with no following characters) the message will be deleted.

Display command:

ATL: Display command; show the actual configuration (IP address of server mail recipient etc.)

Connection command:

ATDT: Connection command, this command will automatically generate connection to the remote SMTP server and send mail to the recipients

5. Display (LED) description

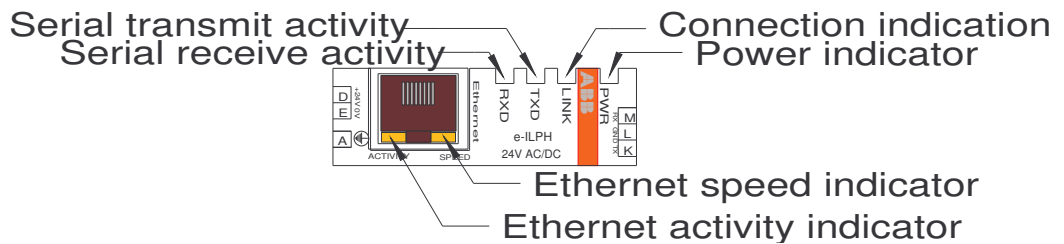

Power: indicates correct power supply on the product

Link: indicates TCP connection is currently active on this e-ILPH

TXD: light during emission on serial port

RXD: Light during reception on serial port

Ethernet speed: indicate current network speed: Amber colour: 10 base-T connection, Green colour: 100 base-T connection

Ethernet activity: Momentary amber colour: Half duplex activity, Momentary green colour: Full duplex activity

Ethernet – serial interface

e-ILPH

6. Update firmware

Update firmware is done through Ethernet connection. The functionality use tftp function implemented into windows package. The update firmware is ROM extension file, to update launch this command into DOS windows from the directory where is located the eILPHxxx.ROM file, xxx is the version number

```
tftp -i 10.33.152.76 PUT eILPH100.ROM X2
```

Where 10.33.152.76 is the remote IP address of e-ILPH that might be updated

And eILPH100.ROM is the code file that contains updated firmware (example with 10.0 version number)

Update time is about 1 second using 100 Mb network, the e-ILPH will be automatically reset after update is completely done.

7. Monitor mode

Monitor mode is expert mode that gives possibilities of setting configuration with more efficiency than configuration menu.

Enter in monitor mode with serial link

Connect terminal to serial port; configure serial line parameters of terminal with 9600 bauds, 8 bits, no parity, 1 stop bit

Switch off e-ILPH, hold on z key on terminal, switch on e-ILPH, by detecting zzz the e-ILPH will automatically switch to monitor mode.

The connection is realized when the terminal prompt with a number followed by >, the value of the number depends on previous command (see following table with command response code)

Enter in monitor mode with Ethernet connection

Connect to the e-ILPH using TELNET or hyper terminal with sock IP connection, in the first menu, instead of enter key press M key this will switch automatically to monitor mode

Command Response Codes

Response	Meaning
0>	OK; no error
1>	No answer from remote device
2>	Cannot reach remote device or no answer
8>	Wrong parameter(s)
9>	Invalid command

All command that is accessible on monitor mode is described in detail in specific document. Here is the description of the most important one as is it could be used often to set IP address during production or installation tools

Command co:

Command used to set IP address and gateway address, also define port number and number of host bit. The command memorize the new value then generate a reset, communication will be lost because of this reset an X is sent by e-ILPH before reset if command is successful

```
co IP1.IP2.IP3.IP4 N GIP1.GIP2.GIP3.GIP4 P
```

Where:

IP1.IP2.IP3.IP4 is IP address of e-ILPH

N is the number of host bits

Ethernet – serial interface

e-ILPH

GIP1.GIP2.GIP3.GIP4 is gateway IP address

P is port number. Entering 0 will generate factory default configuration after the reset.

Command NC:

This command show actual network configuration

Example of result gives by NC command on e-ILPH which IP address is 010.033.152.077, with no gateway set and mask definition is 255.000.000.000 (network class A)

```
IP 010.033.152.077 GW 000.000.000.000 Mask 255.000.000.000
```

Command QU

This command quit the monitor mode; this is not necessary when using co command

8. Automatic switch from MODBUS/TCP to direct mode

This specific mode is used when connected to AC31 PLC range series 50 & 40.

This mode gives possibility of automatic switch from MODBUS mode to direct (transparent mode). The change is done when connection is in MODBUS mode and connection arrives with frame that is not MODBUS frame.

When this new connection or new frame comes to the e-ILPH, it sends specific frame (depending on COM1 or COM2 selected in the configuration) to convert the PLC into programming mode. When the connection is closed, the e-ILPH comes back to MODBUS mode, after having sent a frame to switch back the PLC into MODBUS mode.

While direct connection is open, if already exist a MODBUS connection, on each request exception code 6 (device busy) is sent to the master. This, normally, generates no timeout and keeps efficiency to the whole network.

WARNING: This automatic possibility is allowed if **ONLY ONE** PLC is connected to the e-ILPH

9. Expert debugging mode

Trace debug with telnet

Telnet connectivity gives possibilities of debug serial communication by tracing communication exchange on serial port. This debug tools is accessible on the main menu by entering menu 66 (this menu command is not shown on the list to keep accessibility on to expert team

Trace debug in MODBUS communication

The following trace show example that could be encountered in MODBUS communication:

Connection established

```
From TCP:[73][2][0][0][0][6]<1><3><0><99><0><10><53><211>Wait:31
(1)(3)(20)(0)(110)(110)(101)(99)(116)(105)(0)(0)(0)(0)(110)(101)(99)(116)(105)
(111)(110)(32)(101)(115)(0)(0)(0)(0)(110)(101)(99)(116)(105)(111)(110)(32)(1
01)(115)(116)(97)(98)(108)(105)(0)(0)(0)(0)(0)(0)(101)(99)(116)(105)(111)(110)(3
2)(101)(115)(116)(97)(98)(108)(105)(115)(104)(101)(100)(13)(10)(0)(0)(0)(163)(10
3)(0)(101)(99)(116)(105)(111)(110)(32)(101)(115)(116)(97)(98)(108)(105)(115)(104
)(101)(100)(13)(10)(0)(32)(67)(111)(110)I = 31/CRC OK /Packed
```

```
From TCP:[74][2][0][0][0][6]<1><3><0><99><0><10><53><211>Wait:31
(1)(3)(20)(0)(0)(0)(101)(99)(116)(105)(111)(0)(0)(0)(0)(0)(101)(99)(116)(105)
(111)(110)(32)(101)(115)(116)(0)(0)(0)(0)(0)(0)(101)(99)(116)(105)(111)(110)(32)
(101)(115)(116)(97)(98)(108)(105)(115)(0)(0)(0)(0)(0)(0)(0)(0)(163)(103)(111)(11
0)(32)(101)(115)(116)(97)(98)(108)(105)(115)(104)(101)(100)(13)(10)(0)(32)(67)(1
```

Ethernet – serial interface

e-ILPH

```
11)(110)l = 31/CRC OK /Packed
From TCP:[75][2][0][0][0][6]<1><3><0><99><0><10><53><211>Wait:31
(1)(3)(20)(0)(0)(0)(0)(163)(103)(111)(0)(0)(0)(0)(0)(0)(163)(103)(111)(
110)(32)(101)(115)(116)(0)(0)(0)(0)(0)(0)(0)(0)(163)(103)(111)(110)(32)(101)(115
)(116)(97)(98)(108)(105)(115)(0)(0)(0)(0)(0)(0)(0)(0)(163)(103)(111)(110)(32)(10
1)(115)(116)(97)(98)(108)(105)(115)(104)(101)(100)(13)(10)(0)(0)(0)(163)(103)(0)
(0)(0)(163)(103)(111)(110)(32)(101)(115)(116)(97)(98)(108)(105)(115)(104)(101)(1
00)(13)(10)(0)(32)(67)(111)(110)l = 31/CRC OK /Packed
```

Trace:

Passive mode: Listen for Connection on port: 502

All data are displayed in decimal mode, each byte is inserted in () or []. Data in () are exchanged physically on the serial line, data in [] are additional byte exchange on TCP level.

The byte with indication **From TCP** is the request, this message is followed by **Wait: nn**. This is the number of byte wait for response, this number is calculated with function code and number of data requested

The trace which follows this request line are the byte received on serial line, at the end of frame **l=nn** indicates the number of received characters, **CRC OK** indicates that CRC coming from serial line is OK, and **Packed** indicator shows that message has been sent to the TCP connection.

When connection is stopped a message indicate on which port TCP connection might comes.

Trace debug in SMTP communication

In the following example is shown exchange between e-ILPH and SMTP server mode
DEBUG TELNET Press any key to exit

```
Trace:<10><13>Active mode : Connection to port : 25
Trace:<13><10>Connection established<13><10>
From TCP:220 ArGoSoft Mail Server Freeware, Version 1.8 (1.8.6.0)<13><10>
To TCP:HELO e-ILPH.com<13><10>
From TCP:250 Welcome [10.33.152.77], pleased to meet you<13><10>
To TCP:MAIL FROM:e-ILPH@e-ILPH.com<13><10>
From TCP:250 Sender "e-ILPH@e-ILPH.com" OK...<13><10>
To TCP:RCPT TO:michel.combat@fr.abb.com<13><10>
From TCP:250 Recipient "michel.combat@fr.abb.com" OK...<13><10>
To TCP:DATA<13><10>
From TCP:354 Enter mail, end with "." on a line by itself<13><10>
To TCP:Subject: This is the subject<13><10><13><10>
To TCP:This is first line<13><10>
To TCP:This is second line<13><10>
To TCP:<13><10>.<13><10>
From TCP:250 Message accepted for delivery. <vfohn5tzvdms0uo.220720041023@FR-W-K
KHMN9F><13><10>
To TCP:QUIT<10><13>
From TCP:221 Aba he<13><10>
Trace:<13><10>Disconnect<10><13>
```

Ethernet – serial interface

e-ILPH

In this trace text we could find trace information, such as **Active mode : Connection to port : 25** when connection is started

Some messages are specific to SMTP protocol, such as command like HELO, MAIL FROM etc.

At the end of connection we encountered information trace for Disconnect.