

## AL9 - AL40

### General information

### DC operated, UL rated, 3 phase

#### Application

AL and AL...Z contactors are mainly used for controlling 3-phase motors and for controlling power circuits corresponding to their operating characteristics up to 690 and even 1000 VAC. and 440 VDC.

#### Control circuit types

AL9 - AL40: DC coil with low power consumption of 3W to 3.5W

AL9Z - AL16Z: DC coil with low power consumption of 2.4W. Designed to be directly controlled by PLC.

Quick mounting on DIN rail: EN 50022 and EN 50023 standards:

35 x 7.5mm for AL9 - AL40  
35 x 15mm for AL9 - AL40

Location of side mounted accessories: on right or left hand side.

Holes for screw mounting (screws not supplied). Distance between holes according to EN 50003.

Terminals delivered in open position with captive screws (unused terminal screws must be tightened).

Screwdriver guidance for all terminals makes it possible to use motorized screwdrivers.

All terminals provide protection against accidental direct contact with live parts according to VDE0106 - Part. 100.

All AL9 - AL40 contactor terminals as well as contactor auxiliary contacts and coil terminals ensure IP20 degree of protection according to IEC 60947-1.

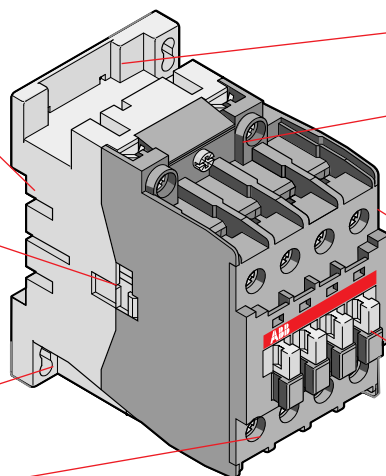

AL9 - AL40

Location of surge suppressors.

Clear marking of coil voltages and frequencies.

Terminal marking according to IEC 60947-4-1, EN 50005, EN 50012 and NEMA standards.

Location of function marker.

Stops for attaching front mounted accessories.

Terminal screws:

- Posidrive (+,-) No° 2 for all AL contactors

## Catalog number explanation

**AL9 - 30 - 10 - 81**

Frame size

Power pole

30 = 3 NO

Coil voltage

(see coil voltage selection chart)

Auxiliary contacts

10 = 1 NO & 0 NC

01 = 0 NO & 1 NC

#### Coil voltage selection

Hz	Contr. type	Volts						
		12	24	48	110	125	220	240
DC	AL	80	81	83	86	87	88	89
DC	AL...Z		15	28				

For other voltages, see page 1.26.