

Reduced voltage Starters



Reduced voltage starters

Open & enclosed

3

Description

- Compact, space saving design
- 8 starter frame sizes, A16 to A750
- Maximum U.L. horsepower ratings
- Mechanically interlocking as standard for wye-delta and autotransformer starters
- Incomplete sequence timer as standard for wye-delta and autotransformer starters
- Remote customer connection point at separate terminal blocks
- Double break contact design with magnetic arc chamber extinguishes arc in the shortest possible time
- NEMA sizes 0, 1, 2, 3, 4, 5, 6, 7

Overload relay protection

Starters, sizes A16–A185, have Class 10 adjustable thermal bimetallic overload relay protection as standard.

Sizes A210 – A750, have selectable Class 10, 20, 30 adjustable electronic overload relay protection as standard.

Electronic overload relay protection is available for other starter sizes.

General information Catalog number information

A110 SA F 1 - 84 C 6D 4 L A

3

Starter size

Starter type

SA - Autotransformer
SG - Wye-delta open transition
SY - Wye-delta closed transition
SH - Part winding
N - NEMA

Combination type

No digit - Non-combination
N - Non-Fusible disconnect
F - Fusible disconnect
B - Thermal magnetic or electronic trip type circuit breaker
M - Motor circuit protection (MCP)

Enclosure

No digit - Open
1 - UL Type 1
2 - UL Type 12
3 - UL Type 3R
4 - UL Type 4
X - UL Type 4X - stainless steel

Coil voltage

See voltage selection chart

Overload range

See overload relay selection chart, page 3.6.

Accessories

A - Start-stop pushbutton
C - 2 pos. sel. switch (off-on)
D - 3 pos. sel. switch (HOA)
E - Pilot light
F - Start-stop pushbutton & pilot light
H - 2 pos. sel. switch & pilot light
J - 3 pos. sel. switch & pilot light

Horsepower

A - 10 N - 200
B - 15 P - 250
C - 20 R - 300
D - 25 S - 350
E - 30 T - 400
F - 40 U - 500
G - 50 V - 600
H - 60 W - 700
J - 75 X - 800
K - 100 Y - 900
L - 125 Z - 1000
M - 150

Line voltage

1 - 200 - 208V
2 - 230 - 240V
3 - 380 - 415V
4 - 460 - 480V
6 - 575 - 600V

Fuse clip

6A- 30A, 600V, Class J
6B- 60A, 600V, Class J
6C- 100A, 600V, Class J
6D- 200A, 600V, Class J
6E- 400A, 600V, Class J
6F- 600A, 600V, Class J
6G- 800A, 600V, Class L
6H- 1200A, 600V, Class L

Circuit breaker amp rating (600V)

6D-15	6M-70	6W-225	6E-700
6E-20	6N-80	6X-250	6F-800
6F-25	6P-90	6Y-300	6G-900
6G-30	6R-100	6Z-350	6H-1000
6H-35	6S-125	6A-400	6J-1200
6J-40	6T-150	6B-450	
6K-50	6U-175	6C-500	
6L-60	6V-200	6D-600	

Circuit breaker amp rating (200V - 480V)

4D-15	4M-70	4W-225	4E-700
4E-20	4N-80	4X-250	4F-800
4F-25	4P-90	4Y-300	4G-900
4G-30	4R-100	4Z-350	4H-1000
4H-35	4-125	4A-400	4J-1200
4J-40	4T-150	4B-450	
4K-50	4U-175	4C-500	
4L-60	4V-200	4D-600	

MCP amp rating (600V)

6A-3	6D-25	6G-	1506K	-600
6N-1200				
6B-5	6E-50	6H-	2506L	-800
6C-10	6F-100	6J-	4006M	-1000

MCP amp rating (200V - 480V)

4A-3	4D-25	4G-150	4K-600	
4N-1200				
4B-5	4E-50	4H-	2504L	-800
4C-10	4F-100	4J-	4004M	-1200

General information Factory modifications

Reduced voltage
starters

3

Control cover accessories – A9-A750

Description	Control suffix ①	List price adder
		NEMA 1 3R 4, 4X & 12
Start-stop pushbutton	A	\$ 72
Fwd-rev-stop pushbutton	B	360
2 position selector switch (Std. ON-OFF)	C	72
3 position selector switch (Std. HAND-OFF-AUTO)	D	72
Pilot light, Red, RUN (Std.)	E	135
Pilot light, Green, RUN	R	135
Pilot light suffix + V= Neon bulb	V	–
Pilot light suffix + X= LED bulb	X	–
Start-stop pushbutton & pilot light	F	207
Fwd-rev-stop pushbutton & pilot light	G	496
2 position selector switch & pilot light	H	207
3 position selector switch & pilot light	J	207
Fast-slow-stop pushbuttons	K	360
Fast-slow-stop pushbuttons & pilot light	L	495
Fast-slow-off-auto selector switch	M	150
Emergency stop	P	100
F suffix + 1NO & 1NC auxiliary contact	T	237
J suffix + 1NO & 1NC auxiliary contact	U	237
Pushbutton (standard START)	Y	36

Special modifications

Contact configuration	Suffix code ①	List price adder
Contactor		
Coil surge suppressor	S	\$ 75
Auxiliary relays		
Type N control relay (4 pole)	CR	225
Electronic timer		
1.5 – 30, On Delay	TN30	300
5 – 100, On Delay	TN100	300
1.5 – 30, Off Delay	TF30	300
5 – 100, Off Delay	TF100	300
Phase failure phase reversal with over and undervoltage relays	PFPR	525
Ground fault protection	GFP	2250
For multi-speed controllers		
Compelling relay	CPR	600
Accelerating relay	ACR	600
Decelerating relay	DCR	600
Meters & metering		
Current transformer	CT	375
Ammeter (including C.T.)	AM	705
Ammeter & ammeter switch	AMS	1800
Voltmeter	VM	1200
Voltmeter & voltmeter switch	VMS	1800
Elapsed time meter	ETM	375
Operation counter	OC	560
Wattmeter	WM	3650
Miscellaneous		
Lightning arrester	LA	320
Space heater, 100W with thermostat	SH	600

Control circuit transformer (standard VA) – A9 - A750 ②

Standard size with fused secondary			Coil suffix	Starter size	CCT VA	List price
Primary	Secondary	Hz				
200/208V	110V	50/60	0	A9 – A40	45 ③	\$ 300
220/240V	110/120V	50/60	7	A9 – A40	50	360
440/480V	110/120V	50/60	8	A50 – A75	75	435
550/600V	110/120V	50/60	9	A95 – A110	100	560
				A145 – A185	150	720
				A210 – A300	250	795
				A400 – A460	150	720 ④
				A580 – A750	250	795 ④

Control circuit transformers do include two primary fuses and one secondary fuse.

- ① Add this suffix to the last digit of the catalog number.
- ② Consult factory if additional VA is required.
- ③ Does not include primary fusing.
- ④ A400 - A750 utilizes the AF wide range coil with a lower coil consumption than A210 - A300.

Additional auxiliary contact blocks – A9 – A750

Contact configuration	Suffix code ①	A9 – A110 list price adder	A145 – A750 list price adder
1 N.O.	10	\$ 20	–
1 N.C.	01	20	–
2 N.O.	20	30	–
1 N.O. & 1 N.C.	11	30	\$ 30
2 N.C.	02	30	–
4 N.O.	40	60	–
3 N.O. & 1 N.C.	31	60	–
2 N.O. & 2 N.C.	22	60	60
1 N.O. & 3 N.C.	13	60	–
4 N.C.	04	60	–
3 N.O. & 3 N.C.	33	90	90

Reduced voltage & multi-speed starters – price adders

Starter size	Non-fusible switch price adder	Fusible switch price adder	MCCB or MCP price adder
A9	\$ 990	\$ 1008	\$ 1287
A12	990	1008	1287
A16	990	1008	1287
A26	990	1008	1287
A30	990	1224	1350
A40	990	1224	1350
A50	1152	1224	1350
A63	1230	1350	1785
A75	1494	1602	1809
A95 – A110	2310	2565	2982
A145	3042	3366	4158
A185	3300	3735	4533
A210	3450	3825	6000
A260	3744	4068	6849
A300	4200	6000	8750
A400	6600	9450	9030
A460	8200	11,100	9475
A580	8400	11,800	10,200
A750	9000	12,450	12,900

Hazardous location enclosure accessories, NEMA 7 & 9

Item	Catalog ① Suffix No.	List price
3R Breather/drain	A	\$ 80
Start PB green	B	180
Stop PB red	C	180
St/St dual PB	D	360
Em. Stop mush momentary	E	220
Em. Stop mush maintained	F	460
Black PB N.O. auxiliary	G	180
Black PB N.C. auxiliary	H	180
Pilot light	J	180
Illuminated PB	K	460
Push-to-test pilot light	L	450
Potentiometer	M	460
2-Pos Selector Maintained	N	260
2-Pos Selector spring L to R	P	280
2-Pos Selector spring R to L	Q	280
3-Pos Selector sw. main.	R	260
3-Pos Selector spring L to R	S	280
3-Pos Selector spring R to L	T	280
3-Pos Selector spring to C	U	280
2-Pos Selector key operated	V	450
3-Pos Selector key operated	W	450

Auto-transformer, non-combination type

A16 - A750

Three phase

3

UL motor switching current	Maximum ratings – UL Listed				Open type		UL Type 1 (Indoor metal)	
	Maximum motor horsepower ratings ^①				Catalog number	List price	Catalog number	List price
	200/208V	230/240V	460/480V	575/600V				
UL rated								
17	5	5	10	15	A16SA-84Δ	\$ 3987	A16SA1-84Δ	\$ 5103
28	7.5	10	20	25	A26SA-84Δ	4341	A26SA1-84Δ	5457
42	10	15	30	40	A40SA-84Δ	4698	A40SA1-84Δ	5814
54	15	20	40	50	A50SA-84Δ	4887	A50SA1-84Δ	6003
65	20	25	50	50	A63SA-84Δ	5130	A63SA1-84Δ	6246
80	25	30	60	75	A75SA-84Δ	5787	A75SA1-84Δ	6471
95	30	30	60	75	A95SA-84Δ	9300	A95SA1-84Δ	9800
110	30	40	75	100	A110SA-84Δ	9972	A110SA1-84Δ	10,694
130	40	50	100	125	A145SA-84Δ	10,863	A145SA1-84Δ	11,853
156	50	60	125	150	A185SA-84Δ	14,334	A185SA1-84Δ	16,880
192	60	75	150	200	A210SA-84Δ	17,196	A210SA1-84Δ	19,781
248	75	100	200	250	A260SA-84Δ	19,670	A260SA1-84Δ	21,668
302	100	—	250	300	A300SA-84Δ	24,042	A300SA1-84Δ	26,034
414	125	150	350	400	A400SA-70Δ	30,996	A400SA1-70Δ	32,981
480	150	200	400	500	A460SA-70Δ	35,978	A460SA1-70Δ	39,182
590	200	250	500	600	A580SA-70Δ	52,562	A580SA1-70Δ	55,898
810	250	300	600	700	A750SA-70Δ	59,250	A750SA1-70Δ	62,618

NEMA rated								
NEMA size	Continuous current	200V	230V	460/575V				
0	18	3	3	5	A16N0SA-84Δ	\$ 3987	A16NSA1-84Δ	\$ 5103
1	27	7.5	7.5	10	A26N1SA-84Δ	4341	A26NSA1-84Δ	5457
2	45	10	15	25	A50N2SA-84Δ	4887	A50NSA1-84Δ	6003
3	90	25	30	50	A75N3SA-84Δ	5787	A75NSA1-84Δ	6471
4	135	40	50	100	A145N4SA-84Δ	10,863	A145NSA1-84Δ	11,853
5	270	75	100	200	A260N5SA-84Δ	19,670	A260NSA1-84Δ	21,668
6	540	150	200	400	A460N6SA-70Δ	35,978	A460NSA1-70Δ	39,182
7	810	—	300	600	A750N7SA-70Δ	59,250	A750NSA1-70Δ	62,618

Δ Overload relay suffix code. Select from the overload relay selection chart on page 3.6.

Description

An autotransformer starter reduces inrush current by using a transformer in the line just ahead of the motor to step down the voltage applied to the motor terminals. By reducing the voltage, the current drawn from the line is reduced during start-up.

When the setting time on the timer has expired, the autotransformer is bypassed. The 1S contactor drops out, the run contactor closes, and the 2S contactor opens, proving full voltage to the motor.

The ABB autotransformer starter is a closed transition type, meaning that the motor remains connected to the line during the entire acceleration period.

The transformer has three taps which provide 50%, 65% and 80% of full line voltage. At delivery, the transformer is connected to the 65% tap; the inrush current will be reduced to 42% of normal; and the starting torque will be reduced to 42%.

The autotransformer starter can be used for any squirrel-cage motor.

Factory modifications

See page 3.3

Coil voltage selection

All AC operated catalog numbers include a 120VAC coil. To select other coil voltages, substitute the code from the Coil Voltage Selection Chart for the two digits after the last dash in the catalog number.

Ex.: A 240V coil is required for an A75 starter: A75SA-84Δ

Coil voltage selection – A9 - A300 ①

Hz	Cntr type	Volts																
		12	24	48	110	120	125	208	220	240	277	380	415	440	480	500	600	
60	A		81	83	84	84			34	36	80	42		86	86	51	53	55
50	A		81	83	84						80			85	86			55

For other voltages, see page 1.26.

Coil voltage selection – A400 - A750 ①

Hz	type	Cntr/Volts			
		24 - 60	48 - 130	100 - 250	250 - 500
60	AF	68	69	70	71 ②
50	AF	68	69	70	71 ②
DC	AF	68	69	70	71 ②

Control transformer voltage selection chart

Hz	Type	Volts			
		208/120	230 – 240/120	460 – 480/120	575 – 600/120
50/60	A/AF	0	7	8	9

For other voltages, consult factory.

① For AF50 – AF 300 starters, consult factory.

② AF400 - AF750 only.

Auto-transformer – non-combination type

A16 - A750

Three phase

Reduced voltage
starters

3

UL Type 3R (Outdoor metal)		UL Type 12 (Metal dustight)		UL Type 4 (Watertight)		UL Type 4X (Stainless steel)	
Catalog number	List price	Catalog number	List price	Catalog number	List price	Catalog number	List price
UL rated							
A16SA3-84Δ	\$ 5823	A16SA2-84Δ	\$ 5823	A16SA4-84Δ	\$ 6993	A16SAX-84Δ	\$ 8550
A26SA3-84Δ	6177	A26SA2-84Δ	6177	A26SA4-84Δ	7347	A26SAX-84Δ	8888
A40SA3-84Δ	6549	A40SA2-84Δ	6549	A40SA4-84Δ	7719	A40SAX-84Δ	9375
A50SA3-84Δ	6723	A50SA2-84Δ	6723	A50SA4-84Δ	7893	A50SAX-84Δ	9600
A63SA3-84Δ	7694	A63SA2-84Δ	7694	A63SA4-84Δ	9014	A63SAX-84Δ	10,725
A75SA3-84Δ	8181	A75SA2-84Δ	8181	A75SA4-84Δ	9261	A75SAX-84Δ	10,988
A95SA3-84Δ	11,200	A95SA2-84Δ	11,200	A95SA4-84Δ	12,400	A95SAX-84Δ	13,600
A110SA3-84Δ	12,323	A110SA2-84Δ	12,323	A110SA4-84Δ	13,388	A110SAX-84Δ	14,700
A145SA3-84Δ	14,013	A145SA2-84Δ	14,013	A145SA4-84Δ	16,983	A145SAX-84Δ	18,300
A185SA3-84Δ	18,972	A185SA2-84Δ	18,972	A185SA4-84Δ	21,951	A185SAX-84Δ	24,450
A210SA3-84Δ	21,842	A210SA2-84Δ	21,842	A210SA4-84Δ	24,812	A210SAX-84Δ	27,600
A260SA3-84Δ	24,098	A260SA2-84Δ	24,098	A260SA4-84Δ	26,798	A260SAX-84Δ	29,400
A300SA3-84Δ	28,391	A300SA2-84Δ	28,391	A300SA4-84Δ	31,184	A300SAX-84Δ	33,000
A400SA3-70Δ	35,247	A400SA2-70Δ	35,247	A400SA4-70Δ	38,807	A400SAX-70Δ	41,175
A460SA3-70Δ	42,557	A460SA2-70Δ	42,557	A460SA4-70Δ	45,932	A460SAX-70Δ	50,700
A580SA3-70Δ	59,997	A580SA2-70Δ	59,997	A580SA4-70Δ	62,324	A580SAX-70Δ	68,700
A750SA3-70Δ	65,993	A750SA2-70Δ	65,993	A750SA4-70Δ	69,368	A750SAX-70Δ	75,300
NEMA rated							
A16NSA3-84Δ	\$ 5823	A16NSA2-84Δ	\$ 5823	A16NSA4-84Δ	\$ 6993	A16NSAX-84Δ	\$ 8550
A26NSA3-84Δ	6117	A26NSA2-84Δ	6177	A26NSA4-84Δ	7347	A26NSAX-84Δ	8888
A50NSA3-84Δ	6723	A50NSA2-84Δ	6723	A50NSA4-84Δ	7893	A50NSAX-84Δ	9600
A75NSA3-84Δ	8181	A75NSA2-84Δ	8181	A75NSA4-84Δ	9261	A75NSAX-84Δ	10,988
A145NSA3-84Δ	14,013	A145NSA2-84Δ	14,013	A145NSA4-84Δ	16,983	A145NSAX-84Δ	18,300
A260NSA3-84Δ	24,098	A260NSA2-84Δ	24,098	A260NSA4-84Δ	26,798	A260NSAX-84Δ	29,400
A460NSA3-70Δ	42,557	A460NSA2-70Δ	42,557	A460NSA4-70Δ	45,932	A460NSAX-70Δ	50,700
A750NSA3-70Δ	65,993	A750NSA2-70Δ	65,993	A750NSA4-70Δ	69,368	A750NSAX-70Δ	75,300

Δ Overload relay suffix code. Select from the overload relay selection chart on page 3.6.

Control transformer option

Contactor size	VA rating	List price adder
A9 – A40	45 ①	\$ 300
A9 – A40	50	360
A50 – A75	75	435
A95 – A110	100	560
A145 – A185	150	720
A210 – A300	250	795
A400 – A460	150	720 ②
A580 – A750	250	795 ②

① No primary fusing provided.

② A400 - A750 utilizes the AF wide range coil with a lower coil consumption than A210 - A300.

Wye-delta, open transition

A26 - A750

Three phase

3

UL motor switching current	Maximum ratings – UL Listed				Open type		UL Type 1 (Indoor metal)	
	Maximum motor horsepower ratings ^①				Catalog number	List price	Catalog number	List price
	200/208V	230/240V	460/480V	575/600V				
UL rated								
28	15	15	40	40	A26SG-84Δ‡	\$ 3038	A26SG1-84Δ‡	\$ 3092
34	15	20	40	50	A30SG-84Δ‡	3347	A30SG1-84Δ‡	3392
42	20	25	50	60	A40SG-84Δ‡	3450	A40SG1-84Δ‡	3494
54	25	30	60	75	A50SG-84Δ‡	3515	A50SG1-84Δ‡	3659
65	30	40	75	100	A63SG-84Δ‡	3615	A63SG1-84Δ‡	4704
80	40	50	100	125	A75SG-84Δ‡	4766	A75SG1-84Δ‡	5324
95	50	60	125	150	A95SG-84Δ‡	6600	A95SG1-84Δ‡	6900
110	60	60	150	150	A110SG-84Δ‡	8834	A110SG1-84Δ‡	9222
130	75	75	150	200	A145SG-84Δ‡	10,103	A145SG1-84Δ‡	11,333
156	75	100	200	250	A185SG-84Δ‡	13,133	A185SG1-84Δ‡	14,120
192	100	125	250	300	A210SG-84Δ‡	15,498	A210SG1-84Δ‡	16,500
248	125, 150	150	300, 350	350, 400	A260SG-84Δ‡	17,960	A260SG1-84Δ‡	19,958
302	150	200	400	500	A300SG-84Δ‡	25,950	A300SG1-84Δ‡	27,900
414	200, 250	250	500	700	A400SG-70Δ‡	36,000	A400SG1-70Δ‡	38,916
480	300	300	650	850	A460SG-70Δ‡	38,506	A460SG1-70Δ‡	42,710
590	350	400	800	1000	A580SG-70Δ‡	49,409	A580SG1-70Δ‡	51,018
810	450	500	1000	1250	A750SG-70Δ‡	54,401	A750SG1-70Δ‡	57,605

NEMA rated								
NEMA size	Continuous current	200V	230V	460/575V				
1	27	10	10	15	A26N1SG-84Δ‡	\$ 3038	A26NSG1-84Δ‡	\$ 3092
2	45	20	25	40	A50N2SG-84Δ‡	3515	A50NSG1-84Δ‡	3659
3	90	40	50	75	A75N3SG-84Δ‡	4766	A75NSG1-84Δ‡	5324
4	135	60	75	150	A145N4SG-84Δ‡	10,103	A145NSG1-84Δ‡	11,333
5	270	150	150	300	A260N5SG-84Δ‡	17,960	A260NSG1-84Δ‡	19,958
6	540	300	350	700	A460N6SG-70Δ‡	39,506	A460NSG1-70Δ‡	42,710
7	810	500	500	1000	A750N7SG-70Δ‡	54,401	A750NSG1-70Δ‡	57,605

Δ Overload Relay suffix code. Select from the overload relay selection chart on page 3.6.
‡ Horsepower and line voltage suffix code. Select from page 3.74.

Description

The wye-delta open transition starter starts the motor by closing the S and 1M contactors which energize the windings in wye. The inrush current in wye is reduced to 33% of what it would be if the motor was started with an across the line starter.

The starting time in wye is adjustable with a timer. After the elapsed time, the S contactor opens which closes the 2M contactor; there is a short period (about 50ms) when the motor is not energized; and then the motor runs full voltage in delta.

A wye-delta starter requires a wye-delta wound motor with all six leads terminated outside the motor housing.

Factory modifications

See page 3.3

Contactors and overload relays are sized at 58% of full load amps!

Coil voltage selection

All AC operated catalog numbers include a 120VAC coil. To select other coil voltages, substitute the code from the Coil Voltage Selection Chart for the two digits after the last dash in the catalog number.

Ex.: A 240V coil is required for an A75 starter: A75SG1-80Δ

Coil voltage selection – A9 - A300 ①

Hz	Cntr	Volts															
		12	24	48	110	120	125	208	220	240	277	380	415	440	480	500	600
60	A		81	83	84	84		34	36	80	42		86	86	51	53	55
50	A		81	83	84				80				85	86			55

For other voltages, see page 1.26.

Coil voltage selection – A400 - A750 ①

Hz	Cntr	Volts			
		24 - 60	48 - 130	100 - 250	250 - 500
60	AF	68	69	70	71 ②
50	AF	68	69	70	71 ②
DC	AF	68	69	70	71 ②

Control transformer voltage selection chart

Hz	Type	Volts			
		208/120	230 – 240/120	460 – 480/120	575 – 600/120
50/60	A/AF	0	7	8	9

For other voltages, consult factory.

① For AF50 - AF300 starters, consult factory.
② For AF400 - AF750 only.

Wye-delta, open transition

A26 - A750

Three phase

Reduced voltage
starters

3

UL Type 3R (Outdoor Metal)		UL Type 12 (Metal Dustight)		UL Type 4 (Watertight)		UL Type 4X (Stainless Steel)	
Catalog number	List price	Catalog number	List price	Catalog number	List price	Catalog number	List price

UL rated

A26SG3-84Δ‡	\$ 3992	A26SG2-84Δ‡	\$ 3992	A26SG4-84Δ‡	\$ 4172	A26SGX-84Δ‡	\$ 4800
A30SG3-84Δ‡	4335	A30SG2-84Δ‡	4335	A30SG4-84Δ‡	4485	A30SGX-84Δ‡	5138
A40SG3-84Δ‡	4425	A40SG2-84Δ‡	4425	A40SG4-84Δ‡	4575	A40SGX-84Δ‡	5400
A50SG3-84Δ‡	4784	A50SG2-84Δ‡	4784	A50SG4-84Δ‡	4874	A50SGX-84Δ‡	5738
A63SG3-84Δ‡	5847	A63SG2-84Δ‡	5847	A63SG4-84Δ‡	5850	A63SGX-84Δ‡	6750
A75SG3-84Δ‡	6674	A75SG2-84Δ‡	6674	A75SG4-84Δ‡	7079	A75SGX-84Δ‡	8438
A95SG3-84Δ‡	7875	A95SG2-84Δ‡	7875	A95SG4-84Δ‡	8205	A95SGX-84Δ‡	9625
A110SG3-84Δ‡	10,508	A110SG2-84Δ‡	10,508	A110SG4-84Δ‡	10,950	A110SGX-84Δ‡	13,125
A145SG3-84Δ‡	12,902	A145SG2-84Δ‡	12,902	A145SG4-84Δ‡	13,865	A145SGX-84Δ‡	16,238
A185SG3-84Δ‡	14,385	A185SG2-84Δ‡	14,385	A185SG4-84Δ‡	15,150	A185SGX-84Δ‡	18,150
A210SG3-84Δ‡	18,215	A210SG2-84Δ‡	18,215	A210SG4-84Δ‡	19,035	A210SGX-84Δ‡	21,450
A260SG3-84Δ‡	22,388	A260SG2-84Δ‡	22,388	A260SG4-84Δ‡	25,088	A260SGX-84Δ‡	27,338
A300SG3-84Δ‡	30,383	A300SG2-84Δ‡	30,383	A300SG4-84Δ‡	31,538	A300SGX-84Δ‡	35,475
A400SG3-84Δ‡	41,150	A400SG2-84Δ‡	41,150	A400SG4-84Δ‡	42,816	A400SGX-84Δ‡	46,575
A460SG3-70Δ‡	46,085	A460SG2-70Δ‡	46,085	A460SG4-70Δ‡	49,460	A460SGX-70Δ‡	51,900
A580SG3-70Δ‡	54,576	A580SG2-70Δ‡	54,576	A580SG4-70Δ‡	57,783	A580SGX-70Δ‡	61,425
A750SG3-70Δ‡	60,980	A750SG2-70Δ‡	60,980	A750SG4-70Δ‡	64,355	A750SGX-70Δ‡	70,125

NEMA rated

A26NSG3-84Δ‡	\$ 3992	A26NSG2-84Δ‡	\$ 3992	A26NSG4-84Δ‡	\$ 4172	A26NSGX-84Δ‡	\$ 4800
A50NSG3-84Δ‡	4784	A50NSG2-84Δ‡	4784	A50NSG4-84Δ‡	4874	A50NSGX-84Δ‡	5738
A75NSG3-84Δ‡	6674	A75NSG2-84Δ‡	6674	A75NSG4-84Δ‡	7079	A75NSGX-84Δ‡	8438
A145NSG3-84Δ‡	12,902	A145NSG2-84Δ‡	12,902	A145NSG4-84Δ‡	13,865	A145NSGX-84Δ‡	16,238
A260NSG3-84Δ‡	22,388	A260NSG2-84Δ‡	22,388	A260NSG4-84Δ‡	25,088	A260NSGX-84Δ‡	27,338
A460NSG3-70Δ‡	46,085	A460NSG2-70Δ‡	46,085	A460NSG4-70Δ‡	49,460	A460NSGX-70Δ‡	51,900
A750NSG3-70Δ‡	60,980	A750NSG2-70Δ‡	60,980	A750NSG4-70Δ‡	64,355	A750NSGX-70Δ‡	70,125

Δ Overload Relay suffix code. Select from the overload relay selection chart on page 3.6.

‡ Horsepower and line voltage suffix code. Select from page 3.74.

Control transformer option

Contactor size	VA rating	List price adder
A9 - A40	45 ①	\$ 300
A9 - A40	50	360
A50 - A75	75	435
A95 - A110	100	560
A145 - A185	150	720
A210 - A300	250	795
A400 - A460	150	720 ②
A580 - A750	250	795 ②

① No primary fusing provided.

② A400 - A750 utilizes the AF wide range coil with a lower coil consumption than A210 - A300.

Wye-delta, closed transition

A26 - A750

Three phase

3

UL motor switching current	Maximum ratings – UL Listed				Open type		UL Type 1 (Indoor metal)	
	Maximum motor horsepower ratings [Ⓢ]				Catalog number	List price	Catalog number	List price
	200/208V	230/240V	460/480V	575/600V				
UL rated								
28	15	15	30	40	A26SY-84Δ‡	\$ 4667	A25SY1-84Δ‡	\$ 4721
34	15	20	40	50	A30SY-84Δ‡	4967	A30SY1-84Δ‡	5021
42	20	25	50	60	A40SY-84Δ‡	5198	A40SY1-84Δ‡	5342
54	25	30	60	75	A50SY-84Δ‡	5396	A50SY1-84Δ‡	5540
65	30	40	75	100	A63SY-84Δ‡	7034	A63SY1-84Δ‡	7592
80	40	50	100	125	A75SY-84Δ‡	7781	A75SY1-84Δ‡	8339
95	50	60	125	—	A95SY-84Δ‡	12,000	A95SY1-84Δ‡	13,000
110	60	60	150	150	A110SY-84Δ‡	13,108	A110SY1-84Δ‡	14,107
130	75	75	150	200	A145SY-84Δ‡	14,324	A145SY1-84Δ‡	15,323
156	75	100	200	250	A185SY-84Δ‡	20,174	A185SY1-84Δ‡	21,173
192	100	125	250	300	A210SY-84Δ‡	23,054	A210SY1-84Δ‡	25,052
248	125, 150	150	300, 350	350, 400	A260SY-84Δ‡	24,413	A260SY1-84Δ‡	26,411
302	150	200	400	500	A300SY-84Δ‡	32,063	A300SY1-84Δ‡	37,061
414	200, 250	250	500	700	A400SY-70Δ‡	39,863	A400SY1-70Δ‡	43,350
480	300	300	650	850	A460SY-70Δ‡	50,522	A460SY1-70Δ‡	53,726
590	350	400	800	1000	A580SY-70Δ‡	65,910	A580SY1-70Δ‡	68,132
810	450	500	1000	1250	A750SY-70Δ‡	71,492	A750SY1-70Δ‡	74,696
NEMA rated								
NEMA size	Continuous current	200V	230V	460/575V				
1	27	10	10	15	A26N1SY-84Δ‡	\$ 4667	A26NSY1-84Δ‡	\$ 4721
2	45	20	25	40	A50N2SY-84Δ‡	5396	A50NSY1-84Δ‡	5540
3	90	40	50	75	A75N3SY-84Δ‡	7781	A75NSY1-84Δ‡	8339
4	135	60	75	150	A145N4SY-84Δ‡	14,324	A145NSY1-84Δ‡	15,323
5	270	150	150	300	A260N5SY-84Δ‡	24,413	A260NSY1-84Δ‡	26,411
6	540	300	350	700	A460N6SY-70Δ‡	50,522	A460NSY1-70Δ‡	53,726
7	810	500	500	1000	A750N7SY-70Δ‡	71,492	A750NSY1-70Δ‡	74,696

Δ Overload Relay suffix code. Select from the overload relay selection chart on page 3.6.
‡ Horsepower and line voltage suffix code. Select from page 3.74.

Description

The wye-delta closed transition starter works the same way as the open transition wye-delta starter except the closed transition version utilizes a set of resistors during the transition from start to run (wye to delta connection). These resistors eliminate the open circuit and prevent transient currents.

Coil voltage selection

All AC operated catalog numbers include a 120VAC coil. To select other coil voltages, substitute the code from the Coil Voltage Selection Chart for the two digits after the last dash in the catalog number.

Ex.: A 240V coil is required for an A75 starter: A75SY1-80Δ

Factory modifications

See page 3.3

Coil voltage selection – A9 - A300 ①

Hz	Cntr type	Volts															
		12	24	48	110	120	125	208	220	240	277	380	415	440	480	500	600
60	A		81	83	84	84		34	36	80	42		86	86	51	53	55
50	A		81	83	84				80			85	86				55

For other voltages, see page 1.26.

Coil voltage selection – A400 - A750 ①

Hz	Cntr type	Volts			
		24 - 60	48 - 130	100 - 250	250 - 500
60	AF	68	69	70	71 ②
50	AF	68	69	70	71 ②
DC	AF	68	69	70	71 ②

Control transformer voltage selection chart

Hz	Type	Volts			
		208/120	230 – 240/120	460 – 480/120	575 – 600/120
50/60	A/AF	0	7	8	9

For other voltages, consult factory.

Contactors and overload relays are sized at 58% of full load amps!

① For AF50 - AF300 starters, consult factory.
② AF400 - AF750 only.

Wye-delta, closed transition A26 - A750 Three phase

Reduced voltage
starters

3

UL Type 3R (Outdoor metal)		Type 12 (Metal dustight)		UL Type 4 (Watertight)		UL Type 4X (Stainless steel)	
Catalog number	List price	Catalog number	List price	Catalog number	List price	Catalog number	List price

UL rated

A26SY3-84Δ‡	\$ 5621	A26SY2-84Δ‡	\$ 5621	A26SY4-84Δ‡	\$ 5801	A26SYX-84Δ‡	\$ 6450
A30SY3-84Δ‡	5921	A30SY2-84Δ‡	5921	A30SY4-84Δ‡	6101	A30SYX-84Δ‡	6788
A40SY3-84Δ‡	6467	A40SY2-84Δ‡	6467	A40SY4-84Δ‡	6557	A40SYX-84Δ‡	7275
A50SY3-84Δ‡	6665	A50SY2-84Δ‡	6665	A50SY4-84Δ‡	6755	A50SYX-84Δ‡	7650
A63SY3-84Δ‡	8942	A63SY2-84Δ‡	8942	A63SY4-84Δ‡	9347	A63SYX-84Δ‡	10,163
A75SY3-84Δ‡	9689	A75SY2-84Δ‡	9689	A75SY4-84Δ‡	10,094	A75SYX-84Δ‡	11,138
A95SY3-84Δ‡	14,900	A95SY2-84Δ‡	14,900	A95SY4-84Δ‡	15,900	A95SYX-84Δ‡	17,000
A110SY3-84Δ‡	15,907	A110SY2-84Δ‡	15,907	A110SY4-84Δ‡	16,870	A110SYX-84Δ‡	18,350
A145SY3-84Δ‡	17,123	A145SY2-84Δ‡	17,023	A145SY4-84Δ‡	18,086	A145SYX-84Δ‡	19,950
A185SY3-84Δ‡	22,973	A185SY2-84Δ‡	22,973	A185SY4-84Δ‡	28,436	A185SYX-84Δ‡	30,225
A210SY3-84Δ‡	27,482	A210SY2-84Δ‡	27,482	A210SY4-84Δ‡	30,182	A210SYX-84Δ‡	32,400
A260SY3-84Δ‡	28,841	A260SY2-84Δ‡	28,841	A260SY4-84Δ‡	31,541	A260SYX-84Δ‡	33,450
A300SY3-84Δ‡	34,991	A300SY2-84Δ‡	34,991	A300SY4-84Δ‡	37,691	A300SYX-84Δ‡	40,688
A400SY3-70Δ‡	41,250	A400SY2-70Δ‡	41,250	A400SY4-70Δ‡	45,330	A400SYX-70Δ‡	48,675
A460SY3-70Δ‡	57,101	A460SY2-70Δ‡	57,101	A460SY4-70Δ‡	60,476	A460SYX-70Δ‡	66,900
A580SY3-70Δ‡	72,749	A580SY2-70Δ‡	72,749	A580SY4-70Δ‡	75,633	A580SYX-70Δ‡	83,625
A750SY3-70Δ‡	78,071	A750SY2-70Δ‡	78,071	A750SY4-70Δ‡	81,446	A750SYX-70Δ‡	88,725

NEMA rated

A26NSY3-84Δ‡	\$ 5621	A26NSY2-84Δ‡	\$ 5621	A26NSY4-84Δ‡	\$ 5801	A26NSYX-84Δ‡	\$ 6450
A50NSY3-84Δ‡	6665	A50NSY2-84Δ‡	6665	A50NSY4-84Δ‡	6755	A50NSYX-84Δ‡	7650
A75NSY3-84Δ‡	9689	A75NSY2-84Δ‡	9689	A75NSY4-84Δ‡	10,094	A75NSYX-84Δ‡	11,138
A145NSY3-84Δ‡	17,123	A145NSY2-84Δ‡	17,023	A145NSY4-84Δ‡	18,086	A145NSYX-84Δ‡	19,950
A260NSY3-84Δ‡	28,841	A260NSY2-84Δ‡	28,841	A260NSY4-84Δ‡	31,541	A260NSYX-84Δ‡	33,450
A460NSY3-70Δ‡	57,101	A460NSY2-70Δ‡	57,101	A460NSY4-70Δ‡	60,476	A460NSYX-70Δ‡	66,900
A750NSY3-70Δ‡	78,071	A580NSY2-70Δ‡	78,071	A750NSY4-70Δ‡	81,446	A750NSYX-70Δ‡	88,725

Δ Overload Relay suffix code. Select from the overload relay selection chart on page 3.6.

‡ Horsepower and line voltage suffix code. Select from page 3.74.

Control transformer option

Contacteur size	VA rating	List price adder
A9 - A40	45 ①	\$ 300
A9 - A40	50	360
A50 - A75	75	435
A95 - A110	100	560
A145 - A185	150	720
A210 - A300	250	795
A400 - A460	150	720 ②
A580 - A750	250	795 ②

① No primary fusing provided.

② A400 - A750 utilizes the AF wide range coil with a lower coil consumption than A210 - A300.

**Reduced voltage
Starters**

**Part winding, non-reversing
A26 - A750
Three phase**

3

UL motor switching current	Maximum ratings – UL Listed				Open type		UL Type 1 (Indoor metal)	
	Maximum motor horsepower ratings ^①				Catalog number	List price	Catalog number	List price
	200/208V	230/240V	460/480V	575/600V				
	UL rated							
28	15	15	40	40	A26SH-84Δ‡	\$ 1917	A26SH1-84Δ‡	\$ 1971
34	15	20	40	50	A30SH-84Δ‡	2097	A30SH1-84Δ‡	2151
42	20	25	50	60	A40SH-84Δ‡	2586	A40SH1-84Δ‡	2643
54	25	30	60	75	A50SH-84Δ‡	2664	A50SH1-84Δ‡	2808
65	30	40	75	100	A63SH-84Δ‡	3305	A63SH1-84Δ‡	3458
80	40	50	100	125	A75SH-84Δ‡	3708	A75SH1-84Δ‡	3960
95	50	60	125	150	A95SH-84Δ‡	6700	A95SH1-84Δ‡	6950
110	60	60	150	150	A110SH-84Δ‡	7142	A110SH1-84Δ‡	7395
130	75	75	150	200	A145SH-84Δ‡	8001	A145SH1-84Δ‡	8469
156	75	100	200	250	A185SH-84Δ‡	10,098	A185SH1-84Δ‡	10,569
192	100	125	250	300	A210SH-84Δ‡	14,310	A210SH1-84Δ‡	14,769
248	125, 150	150	300, 350	350, 400	A260SH-84Δ‡	16,749	A260SH1-84Δ‡	17,739
302	200, 250	200	400	500	A300SH-84Δ‡	30,591	A300SH1-84Δ‡	31,590
414	300	300	600	800	A400SH-70Δ‡	36,000	A400SH1-70Δ‡	37,089
480	300	350	700	900	A460SH-70Δ‡	39,885	A460SH1-70Δ‡	42,938
590	350	400	800	1000	A580SH-70Δ‡	42,158	A580SH1-70Δ‡	51,471
810	500	500	1100	1400	A750SH-70Δ‡	50,994	A750SH1-70Δ‡	56,664

NEMA rated								
NEMA size	Continuous current	200V	230V	460/575V				
1	27	10	10	15	A26N1SH-84Δ‡	\$ 1917	A26NSH1-84Δ‡	\$ 1971
2	45	20	25	40	A50N2SH-84Δ‡	2664	A50NSH1-84Δ‡	2808
3	90	40	50	75	A75N3SH-84Δ‡	3708	A75NSH1-84Δ‡	3960
4	135	75	125	150	A145N4SH-84Δ‡	8001	A145NSH1-84Δ‡	8469
5	270	150	150	350	A260N5SH-84Δ‡	16,749	A260NSH1-84Δ‡	17,739
6	540	250	300	600	A460N6SH-70Δ‡	39,885	A460NSH1-70Δ‡	42,938
7	810	400	450	900	A750N7SH-70Δ‡	50,994	A750NSH1-70Δ‡	56,664

Δ Overload Relay suffix code. Select from the overload relay selection chart on page 3.6.
‡ Horsepower and line voltage suffix code. Select from page 3.74.

Part winding

The part winding starter reduces inrush current by using two different sets of windings in the motor. Therefore, part winding starters can be used only with motors having stator windings divided into two equal parts with the terminals of each part available for external connection.

The part winding starter consists of two across the line starters and a timer. The first starter is used to connect one winding of the motor across the line. The starting current from one winding will be about 50% of the starting current if both windings were connected. The starting torque is correspondingly 50%.

Because the starting torque is so low and will not increase until the second winding is connected, the motor may not begin to accelerate. Therefore, the time delay for the second winding to be energized should not be more than 4 seconds.

When the second winding is energized, the inrush current will increase depending upon the speed of the motor when the second winding is energized.

Coil voltage selection

All AC operated catalog numbers include a 120VAC coil. To select other coil voltages, substitute the code from the Coil Voltage Selection Chart for the two digits after the last dash in the catalog number.

Ex.: A 240V coil is required for an A75 starter: A75SH1-80Δ

Factory modifications

See page 3.3

Coil voltage selection chart

Hz	Cntr type	Volts															
		12	24	48	110	120	125	208	220	240	277	380	415	440	480	500	600
60	A	81	83	84	84		34	36	80	42			86	86	51	53	55
50	A		81	83	84				80				85	86			

For other voltages, see page 1.26.

Hz	Cntr type	Volts			
		24 - 60	48 - 130	100 - 250	250 - 500
60	AF	68	69	70	71 ⊕
50	AF	68	69	70	71 ⊕
DC	AF	68	69	70	71 ⊕

Control transformer voltage selection chart

Hz	Type	Volts			
		208/120	230 - 240/120	460 - 480/120	575 - 600/120
50/60	A/AF	0	7	8	9

For other voltages, consult factory

**Contactors and
overload relays
are sized at 50% of full
load amps!**

① No primary fusing provided.
② AF400 - AF750 only.

Part winding, non-reversing A26 - A750 Three phase

Reduced voltage
starters

3

UL Type 3R (Outdoor metal)		UL Type 12 (Metal dustight)		UL Type 4 (Watertight)		UL Type 4X (Stainless steel)	
Catalog number	List price	Catalog number	List price	Catalog number	List price	Catalog number	List price

UL rated

A26SH3-84Δ‡	\$ 2871	A26SH2-84Δ‡	\$ 2871	A26SH4-84Δ‡	\$ 3051	A26SHX-84Δ‡	\$ 3638
A30SH3-84Δ‡	3075	A30SH2-84Δ‡	3075	A30SH4-84Δ‡	3233	A30SHX-84Δ‡	3825
A40SH3-84Δ‡	3543	A40SH2-84Δ‡	3543	A40SH4-84Δ‡	3723	A40SHX-84Δ‡	4313
A50SH3-84Δ‡	3933	A50SH2-84Δ‡	3933	A50SH4-84Δ‡	4023	A50SHX-84Δ‡	4500
A63SH3-84Δ‡	4583	A63SH2-84Δ‡	4583	A63SH4-84Δ‡	4673	A63SHX-84Δ‡	5363
A75SH3-84Δ‡	5310	A75SH2-84Δ‡	5310	A75SH4-84Δ‡	5715	A75SHX-84Δ‡	6540
A95SH3-84Δ‡	8500	A95SH2-84Δ‡	8500	A95SH4-84Δ‡	8700	A95SHX-84Δ‡	9300
A110SH3-84Δ‡	8745	A110SH2-84Δ‡	8745	A110SH4-84Δ‡	9150	A110SHX-84Δ‡	9900
A145SH3-84Δ‡	10,269	A145SH2-84Δ‡	10,269	A145SH4-84Δ‡	11,232	A145SHX-84Δ‡	12,225
A185SH3-84Δ‡	12,369	A185SH2-84Δ‡	12,369	A185SH4-84Δ‡	13,332	A185SHX-84Δ‡	14,813
A210SH3-84Δ‡	16,569	A210SH2-84Δ‡	16,569	A210SH4-84Δ‡	17,532	A210SHX-84Δ‡	19,050
A260SH3-84Δ‡	20,169	A260SH2-84Δ‡	20,169	A260SH4-84Δ‡	22,869	A260SHX-84Δ‡	26,100
A300SH3-84Δ‡	34,020	A300SH2-84Δ‡	34,020	A300SH4-84Δ‡	36,720	A300SHX-84Δ‡	38,225
A400SH3-70Δ‡	41,589	A400SH2-70Δ‡	41,589	A400SH4-70Δ‡	42,552	A400SHX-70Δ‡	45,263
A460SH3-70Δ‡	47,438	A460SH2-70Δ‡	47,438	A460SH4-70Δ‡	48,401	A460SHX-70Δ‡	49,913
A580SH3-70Δ‡	55,971	A580SH2-70Δ‡	55,971	A580SH4-70Δ‡	56,934	A580SHX-70Δ‡	59,400
A750SH3-70Δ‡	62,064	A750SH2-70Δ‡	62,064	A750SH4-70Δ‡	62,541	A750SHX-70Δ‡	66,150

NEMA rated

A26NSH3-84Δ‡	\$ 2871	A26NSH2-84Δ‡	\$ 2871	A26NSH4-84Δ‡	\$ 3051	A26NSHX-84Δ‡	\$ 3638
A50NSH3-84Δ‡	3933	A50NSH2-84Δ‡	3933	A50NSH4-84Δ‡	4023	A50NSHX-84Δ‡	4500
A75NSH3-84Δ‡	5310	A75NSH2-84Δ‡	5310	A75NSH4-84Δ‡	5715	A75NSHX-84Δ‡	6540
A145NSH3-84Δ‡	10,269	A145NSH2-84Δ‡	10,269	A145NSH4-84Δ‡	11,232	A145NSHX-84Δ‡	12,225
A260NSH3-84Δ‡	20,169	A260NSH2-84Δ‡	20,169	A260NSH4-84Δ‡	22,869	A260NSHX-84Δ‡	26,100
A460NSH3-70Δ‡	47,438	A460NSH2-70Δ‡	47,438	A460NSH4-70Δ‡	48,401	A460NSHX-70Δ‡	49,913
A750NSH3-70Δ‡	62,064	A750NSH2-70Δ‡	62,064	A750NSH4-70Δ‡	62,541	A750NSHX-70Δ‡	66,150

Δ Overload Relay suffix code. Select from the overload relay selection chart on page 3.6.

‡ Horsepower and line voltage suffix code. Select from page 3.74.

Control transformer option

Contactor size	VA rating	List price adder
A9 - A40	45 ①	\$ 300
A9 - A40	50	360
A50 - A75	75	435
A95 - A110	100	560
A145 - A185	150	720
A210 - A300	250	795
A400 - A460	150	720 ②
A580 - A750	250	795 ②

① No primary fusing provided.

② A400 - A750 utilizes the AF wide range coil with a lower coil consumption than A210 - A300.

Circuit diagrams Autotransformer & part winding

Autotransformer – HOA

3 An autotransformer starter reduces inrush current by using a transformer in the line just ahead of the motor to step down the voltage applied to the motor terminals. By reducing the voltage, the current drawn from the line is reduced during start-up.

When the setting time on the timer has expired, the autotransformer is bypassed. The 1S contactor drops out, the run contactor closes, and the 2S contactor opens, proving full voltage to the motor.

The ABB autotransformer starter is a closed transition type, meaning that the motor remains connected to the line during the entire acceleration period.

The transformer has three taps which provide 50%, 65% and 80% of full line voltage. At delivery, the transformer is connected to the 65% tap; the inrush current will be reduced to 42% of normal; and the starting torque will be reduced to 42%.

The autotransformer starter can be used for any squirrel-cage motor.

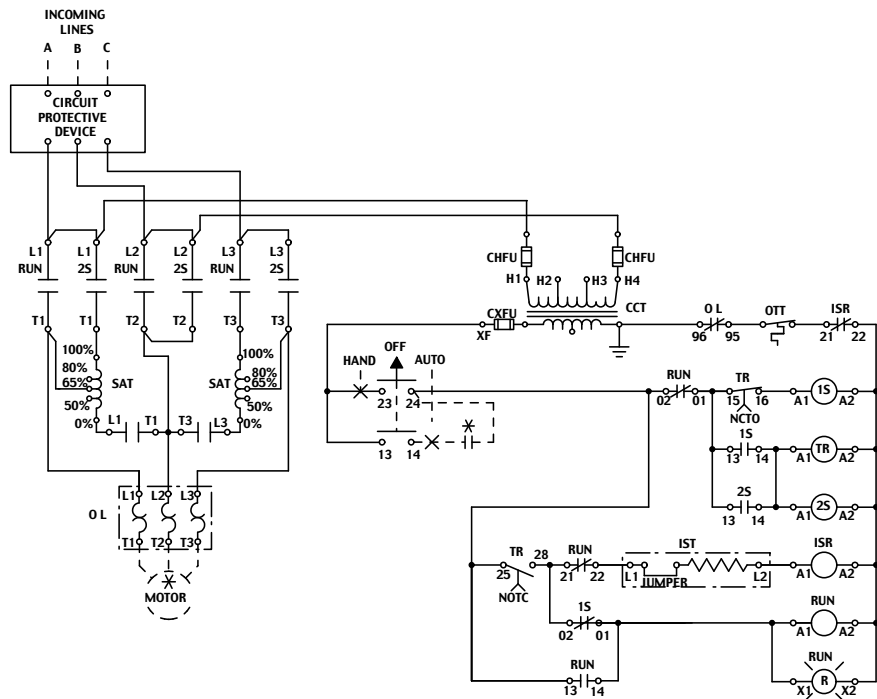

Part winding – STOP-START

The part winding starter reduces inrush current by using two different sets of windings in the motor. Therefore, part winding starters can be used only with motors having stator windings divided into two equal parts with the terminals of each part available for external connection.

The part winding starter consists of two across the line starters and a timer. The first starter is used to connect one winding of the motor across the line. The starting current from one winding will be about 50% of the starting current if both windings were connected. The starting torque is correspondingly 50%.

Because the starting torque is so low and will not increase until the second winding is connected, the motor may not begin to accelerate. Therefore, the time delay for the second winding to be energized should not be more than 4 seconds.

When the second winding is energized, the inrush current will increase depending upon the speed of the motor when the second winding is energized.

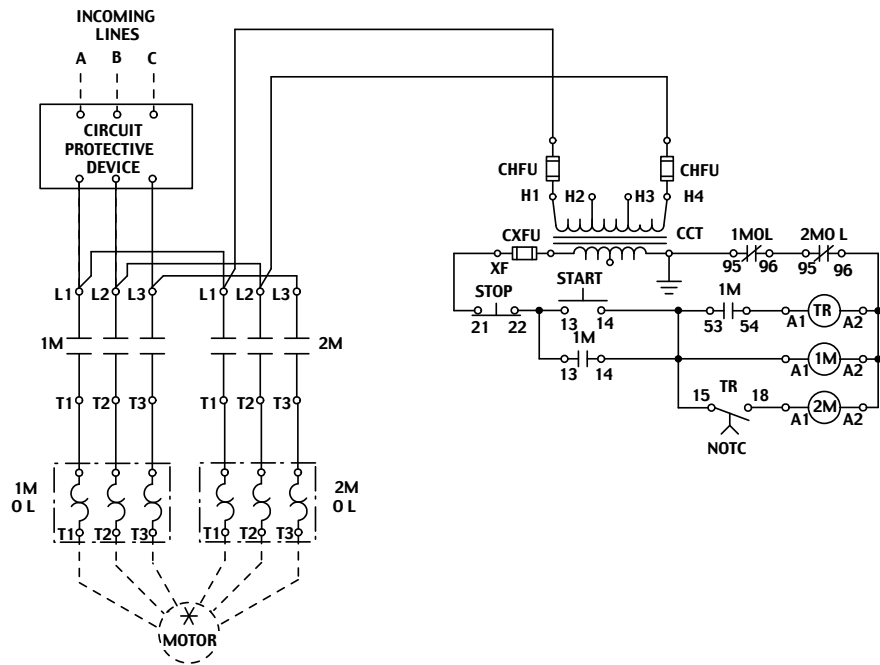

Circuit diagrams

Wye-delta

Reduced voltage starters

3

Wye-delta, open transition – STOP-START

The wye-delta open transition starter starts the motor by closing the S and 1M contactors which energize the windings in wye. The inrush current in wye is reduced to 33% of what it would be if the motor was started with an across the line starter.

The starting time in wye is adjustable with a timer. After the elapsed time, the S contactor opens which closes the 2M contactor; there is a short period (about 50ms) when the motor is not energized; and then the motor runs full voltage in delta.

A wye-delta starter requires a wye-delta wound motor with all six leads terminated outside the motor housing.

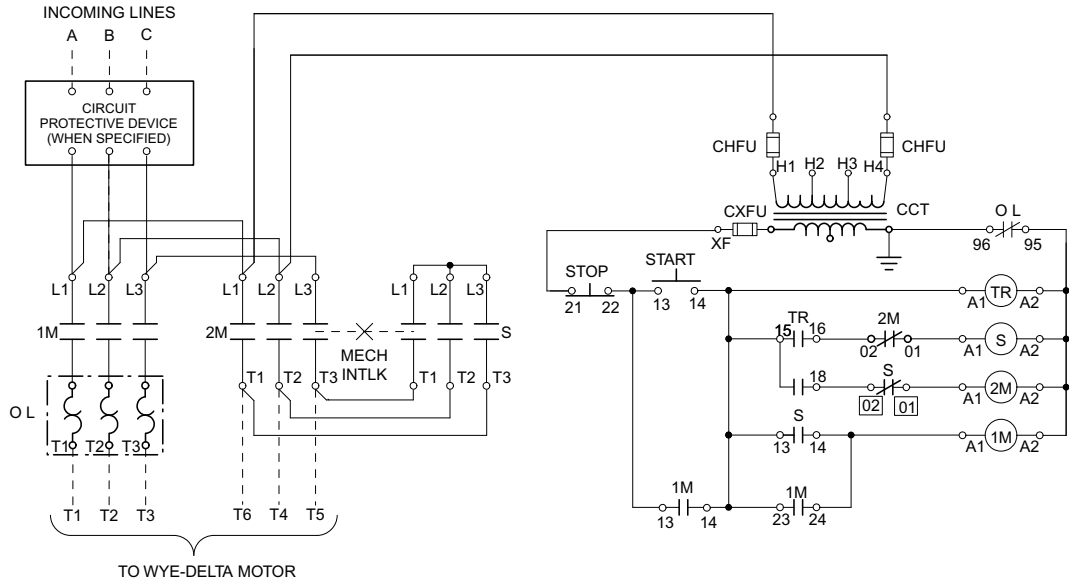

Wye-delta, closed transition – STOP-START

The wye-delta closed transition starter works the same way as the open transition wye-delta starter except the closed transition version utilizes a set of resistors during the transition from start to run (wye to delta connection). These resistors eliminate the open circuit and prevent transient currents.

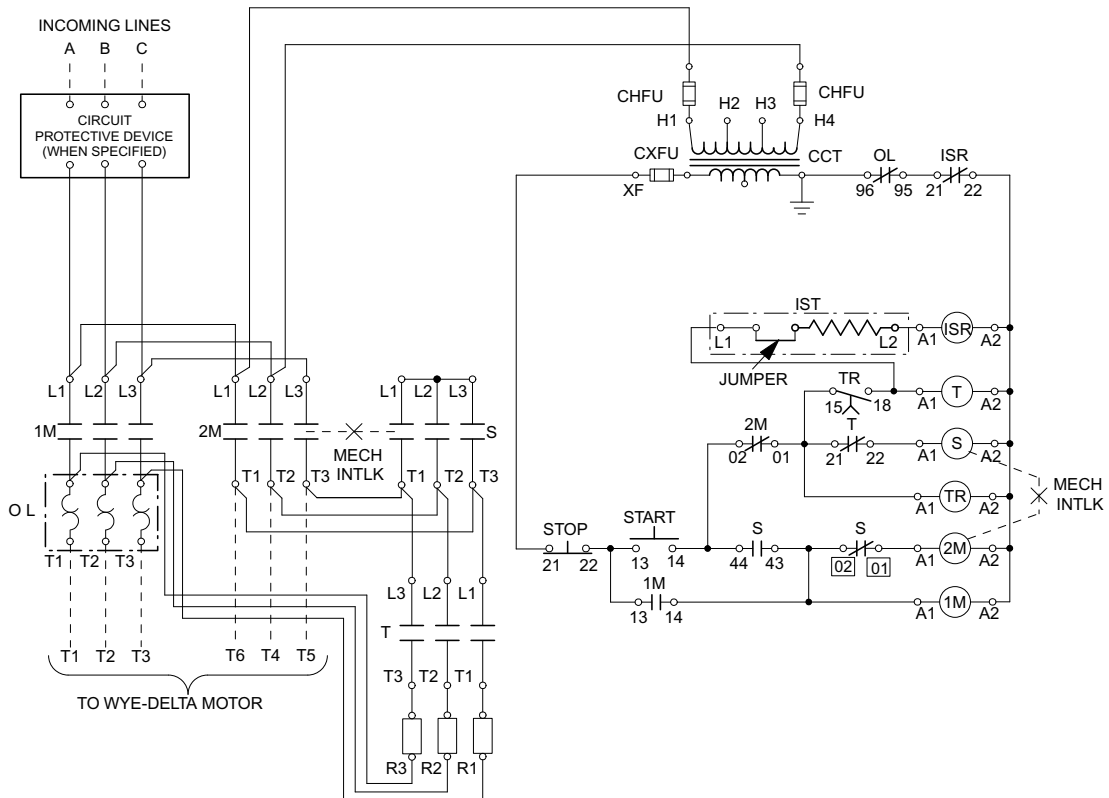

Approximate dimensions Autotransformer w/CCT Autotransformer, non-fused combination w/CCT

3

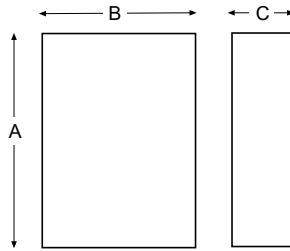

Autotransformer w/CCT

Starter size	Enclosure type	A	B	C
A9 – A40	1	20	16	8
	3R	20	16	8
	4	20	16	8
	4X Stainless	20	16	8
	4X Plastic	20	16	8
A50 – A75	1	24	20	10
	3R	24	20	10
	4	24	20	10
	4X Stainless	24	20	10
	4X Plastic	30	20	12
A95 – A110	1	30	24	12
	3R	30	30	12
	4	30	30	12
	4X Stainless	30	30	12
	4X Plastic	30	30	12
A145 – A260	1	36	30	12
	3R	36	30	12
	4	36	30	12
	4X Stainless	36	30	12
	4X Plastic	–	–	–
A300	1	48	36	17
	3R	48	36	16
	4	–	–	–
	4X Stainless	–	–	–
	4X Plastic	–	–	–
A400 – A750	1	87	36	24
	3R	87	36	24
	4	–	–	–
	4X Stainless	–	–	–
	4X Plastic	–	–	–

Autotransformer, non-fused combination w/CCT

Starter size	Enclosure type	A	B	C
A9 – A40	1	20	16	8
	3R	20	16	8
	4	20	16	8
	4X Stainless	20	16	8
	4X Plastic	20	16	8
A50 – A75	1	30	24	12
	3R	30	24	8
	4	30	24	8
	4X Stainless	30	24	8
	4X Plastic	30	20	12
A95 – A110	1	36	30	12
	3R	36	30	12
	4	36	30	12
	4X Stainless	36	30	12
	4X Plastic	–	–	–
A145 – A260	1	36	30	12
	3R	36	30	12
	4	36	30	12
	4X Stainless	36	30	12
	4X Plastic	–	–	–
A300	1	48	36	17
	3R	48	36	16
	4	48	36	16
	4X Stainless	–	–	–
	4X Plastic	–	–	–
A400 – A750	1	87	36	24
	3R	87	36	24
	4	–	–	–
	4X Stainless	–	–	–
	4X Plastic	–	–	–

Approximate dimensions

Autotransformer fused combination w/CCT
Autotransformer, breaker combination w/CCT

Reduced voltage
starters

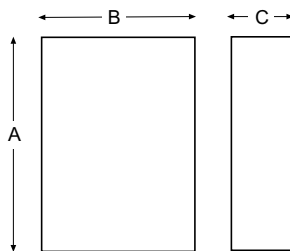

3

Autotransformer, fused combination w/CCT

Starter size	Enclosure type	A	B	C
A9 – A40	1	20	16	8
	3R	20	16	8
	4	20	16	8
	4X Stainless	20	16	8
	4X Plastic	20	16	8
	12	20	16	8
A50 – A75	1	30	24	12
	3R	30	24	10
	4	30	24	10
	4X Stainless	30	24	10
	4X Plastic	30	20	12
	12	30	24	10
A95 – A110	1	36	30	12
	3R	36	30	12
	4	36	30	12
	4X Stainless	36	30	12
	4X Plastic	–	–	–
	12	36	30	12
A145 – A260	1	36	30	12
	3R	36	30	12
	4	36	30	12
	4X Stainless	36	30	12
	4X Plastic	–	–	–
	12	36	30	12
A300	1	48	36	17
	3R	48	36	16
	4	48	36	16
	4X Stainless	–	–	–
	4X Plastic	–	–	–
	12	48	36	16
A400 – A750	1	87	36	24
	3R	87	36	24
	4	–	–	–
	4X Stainless	–	–	–
	4X Plastic	–	–	–
	12	87	36	24

Autotransformer, breaker combination w/CCT

Starter size	Enclosure type	A	B	C
A9 – A40	1	20	16	8
	3R	20	16	8
	4	20	16	8
	4X Stainless	20	16	8
	4X Plastic	20	16	8
	12	20	16	8
A50 – A75	1	30	24	12
	3R	30	24	10
	4	30	24	10
	4X Stainless	30	24	10
	4X Plastic	30	20	12
	12	30	24	10
A95 – A110	1	36	30	12
	3R	36	30	12
	4	36	30	12
	4X Stainless	36	30	12
	4X Plastic	–	–	–
	12	36	30	12
A145 – A260	1	36	30	12
	3R	36	30	12
	4	36	30	12
	4X Stainless	36	30	12
	4X Plastic	–	–	–
	12	36	30	12
A300	1	48	36	17
	3R	48	36	16
	4	48	36	16
	4X Stainless	–	–	–
	4X Plastic	–	–	–
	12	48	36	16
A400 – A750	1	87	36	24
	3R	87	36	24
	4	–	–	–
	4X Stainless	–	–	–
	4X Plastic	–	–	–
	12	87	36	24

Approximate dimensions

Wye-Delta, open transition w/CCT

Wye-Delta, open transition, combination, non-fused

3

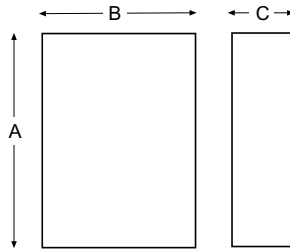

Wye-Delta, open transition w/CCT

Starter size	Enclosure type	A	B	C
A9 – A40	1	14	12	8
	3R	14	12	8
	4	14	12	8
	4X Stainless	14	12	6
	4X Plastic	14	12	7
12	14	12	8	
A50 – A75	1	20	16	8
	3R	20	16	8
	4	20	16	8
	4X Stainless	20	16	8
	4X Plastic	20	16	8
12	20	16	8	
A95 – A110	1	20	16	8
	3R	20	16	8
	4	20	16	8
	4X Stainless	20	16	8
	4X Plastic	20	16	8
12	20	16	8	
A145 – A185	1	30	24	12
	3R	30	20	8
	4	30	20	8
	4X Stainless	30	24	8
	4X Plastic	30	20	12
12	30	20	8	
A210 – A300	1	30	24	12
	3R	30	24	12
	4	30	24	12
	4X Stainless	30	24	12
	4X Plastic	30	20	12
12	30	24	12	
A400	1	36	30	12
	3R	36	30	12
	4	36	30	12
	4X Stainless	36	30	12
	4X Plastic	–	–	–
12	36	30	12	
A460	1	42	30	13
	3R	42	36	12
	4	42	36	12
	4X Stainless	42	36	12
	4X Plastic	–	–	–
12	42	36	12	
A580 – A750	1	42	36	13
	3R	42	36	12
	4	42	36	12
	4X Stainless	42	36	12
	4X Plastic	–	–	–
12	42	36	12	

Wye-Delta, open transition, combination, non-fused

Starter size	Enclosure type	A	B	C
A9 – A40	1	14	12	8
	3R	14	12	8
	4	14	12	8
	4X Stainless	14	12	6
	4X Plastic	14	12	7
12	14	12	8	
A50 – A75	1	20	16	8
	3R	20	16	8
	4	20	16	8
	4X Stainless	20	16	8
	4X Plastic	20	16	8
12	20	16	8	
A95 – A110	1	36	30	8
	3R	36	30	8
	4	36	30	8
	4X Stainless	36	30	8
	4X Plastic	40	30	12
12	36	30	8	
A145 – A185 (NF400)	1	42	36	9
	3R	36	36	8
	4	36	36	8
	4X Stainless	36	36	12
	4X Plastic	–	–	–
12	36	30	8	
A210 (NF400)	1	42	36	9
	3R	36	36	12
	4	36	36	12
	4X Stainless	36	36	12
	4X Plastic	–	–	–
12	36	36	12	
A260 – A300 (NF600)	1	–	–	–
	3R	60	36	10
	4	60	36	10
	4X Stainless	60	36	10
	4X Plastic	–	–	–
12	60	36	10	
A400 (NF800) A460 (NF1200) A580 (NF1200) A750 (NF1600)	1	87	36	24
	3R	87	36	24
	4	87	36	24
	4X Stainless	–	–	–
	4X Plastic	–	–	–
12	87	36	24	

Approximate dimensions

Wye-Delta, open transition, combination, fused
Wye-Delta, open transition, combination, breaker

Reduced voltage
starters

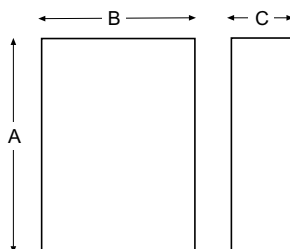

3

Wye-Delta, open transition, combination, fused

Starter size	Enclosure type	A	B	C
A9 – A40	1	14	12	8
	3R	14	12	8
	4	14	12	8
	4X Stainless	14	12	6
	4X Plastic	14	12	7
12	14	12	8	
A50 – A75	1	24	16	8
	3R	24	16	8
	4	24	16	8
	4X Stainless	24	16	8
	4X Plastic	24	16	8
12	24	16	8	
A95 – A110	1	36	30	8
	3R	36	30	8
	4	36	30	8
	4X Stainless	36	30	8
	4X Plastic	40	30	12
12	36	30	8	
A145 (F400) A185 (F600)	1	42	36	9
	3R	36	36	8
	4	36	36	8
	4X Stainless	36	36	12
	4X Plastic	–	–	–
12	36	36	8	
A210 (F600) A260 (F800)	1	–	–	–
	3R	60	36	10
	4	60	36	10
	4X Stainless	60	36	10
	4X Plastic	–	–	–
12	60	36	10	
A300(NF1200+FB) A400(NF1600+FB) A460(NF1600+FB) A580(NF2000+FB) A750(NF3150+FB)	1	87	36	24
	3R	87	36	24
	4	–	–	–
	4X Stainless	–	–	–
	4X Plastic	–	–	–
12	87	36	24	

Wye-Delta, open transition, combination, breaker

Starter size	Enclosure type	A	B	C
A9 – A40	1	14	12	8
	3R	14	12	8
	4	14	12	8
	4X Stainless	16	12	6
	4X Plastic	14	12	7
12	14	12	8	
A50 – A75	1	24	20	8
	3R	24	20	8
	4	24	20	8
	4X Stainless	24	20	8
	4X Plastic	30	20	12
12	24	20	8	
A95 – A110	1	36	30	8
	3R	36	30	8
	4	36	30	8
	4X Stainless	36	30	8
	4X Plastic	40	30	12
12	36	30	8	
A145 (S6) A185 (S6)	1	42	36	9
	3R	36	36	8
	4	36	36	8
	4X Stainless	36	36	12
	4X Plastic	–	–	–
12	36	36	8	
A210 (S7) A300 (S7)	1	42	36	13
	3R	36	36	12
	4	36	36	12
	4X Stainless	36	36	12
	4X Plastic	–	–	–
12	36	36	12	
A400 (S8) A750 (S8)	1	87	36	24
	3R	87	36	24
	4	–	–	–
	4X Stainless	–	–	–
	4X Plastic	–	–	–
12	87	36	24	

Approximate dimensions

Wye-Delta, closed transition w/CCT

Wye-Delta, closed transition, combination, non-fused

3

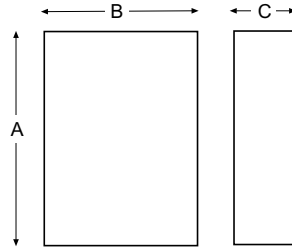

Wye-Delta, closed transition w/CCT

Starter size	Enclosure type	A	B	C
A9 – A40	1	20	16	8
	3R	20	16	8
	4	20	16	8
	4X Stainless	20	16	8
	4X Plastic	20	16	8
	12	20	16	8
A50 – A75	1	24	20	10
	3R	24	20	10
	4	24	20	10
	4X Stainless	24	20	10
	4X Plastic	30	20	12
	12	24	20	10
A95 – A110	1	30	24	10
	3R	30	30	12
	4	30	30	12
	4X Stainless	30	30	12
	4X Plastic	30	30	12
	12	30	30	10
A145 – A260	1	36	30	12
	3R	36	30	12
	4	36	30	12
	4X Stainless	36	30	12
	4X Plastic	-	-	-
	12	36	30	12
A300	1	48	36	17
	3R	48	36	16
	4	-	-	-
	4X Stainless	-	-	-
	4X Plastic	-	-	-
	12	48	36	16
A400 – A750	1	87	36	24
	3R	87	36	24
	4	-	-	-
	4X Stainless	-	-	-
	4X Plastic	-	-	-
	12	87	36	24

Wye-Delta, closed transition, combination, non-fused

Starter size	Enclosure type	A	B	C
A9 – A40	1	14	12	8
	3R	14	12	8
	4	14	12	8
	4X Stainless	14	12	6
	4X Plastic	14	12	7
	12	14	12	8
A50 – A75	1	20	16	8
	3R	20	16	8
	4	20	16	8
	4X Stainless	20	16	8
	4X Plastic	20	16	8
	12	20	16	8
A95 – A110	1	36	30	8
	3R	36	30	8
	4	36	30	8
	4X Stainless	36	30	8
	4X Plastic	40	30	12
	12	36	30	8
A145 – A185 (NF400)	1	42	36	9
	3R	36	36	8
	4	36	36	8
	4X Stainless	36	36	12
	4X Plastic	-	-	-
	12	36	36	8
A210 (NF400)	1	42	36	9
	3R	36	36	12
	4	36	36	12
	4X Stainless	36	36	12
	4X Plastic	-	-	-
	12	36	36	12
A260 – A300 (NF600)	1	-	-	-
	3R	60	36	10
	4	60	36	10
	4X Stainless	60	36	10
	4X Plastic	-	-	-
	12	60	36	10
A400 (NF800)	1	87	36	24
A460 (NF1200)	3R	87	36	24
A580 (NF1200)	4	87	36	24
A750 (NF1600)	4X Stainless	-	-	-
	4X Plastic	-	-	-
	12	87	36	24

Approximate dimensions

Wye-Delta, closed transition, combination, fused
Wye-Delta, closed transition, combination, breaker

Reduced voltage
starters

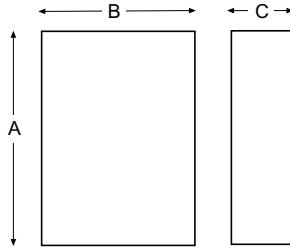

3

Wye-Delta, closed transition, combination, fused

Starter size	Enclosure type	A	B	C
A9 – A40	1	14	12	8
	3R	14	12	8
	4	14	12	8
	4X Stainless	14	12	6
	4X Plastic	14	12	7
12	14	12	8	
A50 – A75	1	24	16	8
	3R	24	16	8
	4	24	16	8
	4X Stainless	24	16	8
	4X Plastic	24	16	8
12	24	16	8	
A95 – A110	1	36	30	8
	3R	36	30	8
	4	36	30	8
	4X Stainless	36	30	8
	4X Plastic	40	30	12
12	36	30	8	
A145 (F400) A185 (F600)	1	42	36	9
	3R	36	36	8
	4	36	36	8
	4X Stainless	36	36	12
	4X Plastic	–	–	–
12	36	36	8	
A210 (F600) A260 (F800)	1	–	–	–
	3R	60	36	10
	4	60	36	10
	4X Stainless	60	36	10
	4X Plastic	–	–	–
12	60	36	10	
A300(NF1200+FB) A400(NF1600+FB) A460(NF1600+FB) A580(NF2000+FB) A750(NF3150+FB)	1	87	36	24
	3R	87	36	24
	4	–	–	–
	4X Stainless	–	–	–
	4X Plastic	–	–	–
12	87	36	24	

Wye-Delta, closed transition, combination, breaker

Starter size	Enclosure type	A	B	C
A9 – A40	1	20	16	8
	3R	20	16	8
	4	20	16	8
	4X Stainless	20	16	8
	4X Plastic	20	16	8
12	20	16	8	
A50 – A75	1	30	24	12
	3R	30	24	8
	4	30	24	8
	4X Stainless	30	24	8
	4X Plastic	30	20	12
12	30	24	8	
A95 – A110	1	36	30	8
	3R	36	30	8
	4	36	30	8
	4X Stainless	36	30	8
	4X Plastic	–	–	–
12	36	30	8	
A145 (S6) A185 (S6)	1	42	36	9
	3R	36	36	8
	4	36	36	8
	4X Stainless	36	36	12
	4X Plastic	–	–	–
12	36	36	8	
A210 (S7) A300 (S7)	1	42	36	13
	3R	36	36	12
	4	36	36	12
	4X Stainless	36	36	12
	4X Plastic	–	–	–
12	36	36	12	
A400 (S8) A460 (S8) A580 (S8) A750 (S8)	1	87	36	24
	3R	87	36	24
	4	–	–	–
	4X Stainless	–	–	–
	4X Plastic	–	–	–
12	87	36	24	

Approximate dimensions
Part winding w/CCT
Part winding, non-fused combination w/CCT

3

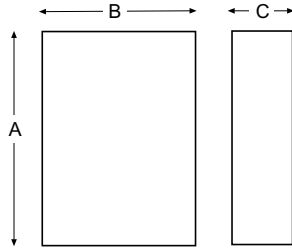

Part winding w/CTT

Starter size	Enclosure type	A	B	C
A9 – A40	1	12	10	6
	3R	14	12	8
	4	14	12	6
	4X Stainless	14	12	6
	4X Plastic	14	12	7
	12	14	12	8
A50 – A75	1	14	12	8
	3R	14	12	8
	4	14	12	6
	4X Stainless	14	12	6
	4X Plastic	14	12	7
	12	14	12	8
A95 – A110	1	20	16	8
	3R	20	16	8
	4	20	16	8
	4X Stainless	20	16	8
	4X Plastic	20	16	8
	12	20	16	8
A145 – A185	1	30	24	12
	3R	30	20	8
	4	30	20	8
	4X Stainless	30	24	8
	4X Plastic	30	20	12
	12	30	20	8
A210 – A300	1	30	24	12
	3R	30	20	10
	4	30	20	10
	4X Stainless	30	24	12
	4X Plastic	30	20	12
	12	30	20	10
A400	1	36	30	12
	3R	36	24	12
	4	36	24	12
	4X Stainless	36	24	12
	4X Plastic	–	–	–
	12	36	24	12
A460	1	42	30	13
	3R	42	36	12
	4	42	36	12
	4X Stainless	42	36	12
	4X Plastic	–	–	–
	12	42	36	12
A580	1	36	30	12
	3R	36	24	12
	4	36	24	12
	4X Stainless	36	24	12
	4X Plastic	–	–	–
	12	36	24	12
A750	1	42	30	13
	3R	42	36	12
	4	42	36	12
	4X Stainless	42	36	12
	4X Plastic	–	–	–
	12	42	36	12

Part winding, non-fused combination w/CCT

Starter size	Enclosure type	A	B	C
A9 – A40	1	14	12	8
	3R	14	12	8
	4	14	12	6
	4X Stainless	14	12	6
	4X Plastic	14	12	7
	12	14	12	8
A50 – A75	1	20	16	8
	3R	20	16	8
	4	20	16	8
	4X Stainless	20	16	8
	4X Plastic	20	16	8
	12	20	16	8
A95 – A110	1	30	24	12
	3R	30	24	8
	4	30	24	8
	4X Stainless	30	24	8
	4X Plastic	30	30	12
	12	30	24	8
A145 – A185	1	30	24	8
	3R	30	24	8
	4	30	24	8
	4X Stainless	30	24	8
	4X Plastic	33	25	12
	12	30	24	8
A210	1	30	24	12
	3R	30	24	10
	4	30	24	10
	4X Stainless	30	24	10
	4X Plastic	33	25	12
	12	30	24	10
A260 – A300	1	36	30	12
	3R	30	30	10
	4	30	30	10
	4X Stainless	36	30	12
	4X Plastic	40	30	12
	12	30	30	10
A400 – A460	1	48	36	13
	3R	48	36	12
	4	48	36	12
	4X Stainless	48	36	12
	4X Plastic	–	–	–
	12	48	36	12
A580 – A750	1	87	36	24
	3R	87	36	24
	4	87	36	24
	4X Stainless	–	–	–
	4X Plastic	–	–	–
	12	87	36	24

Approximate dimensions

Part winding, fused combination w/CCT
Part winding, breaker combination w/CCT

Reduced voltage
starters

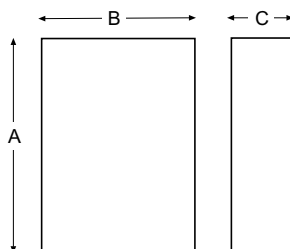

3

Part winding, fused combination w/CCT

Starter size	Enclosure type	A	B	C
A9 – A40	1	20	16	8
	3R	20	16	8
	4	20	16	8
	4X Stainless	20	16	8
	4X Plastic	20	16	8
12	20	16	8	
A50 – A75	1	24	20	8
	3R	24	20	8
	4	24	20	8
	4X Stainless	24	20	8
	4X Plastic	24	16	8
12	24	20	8	
A95 – A110	1	30	24	10
	3R	30	24	10
	4	30	24	10
	4X Stainless	30	24	10
	4X Plastic	30	30	12
12	30	24	10	
A145 – A210	1	36	30	8
	3R	30	30	8
	4	30	30	8
	4X Stainless	30	30	8
	4X Plastic	40	30	12
12	30	30	8	
A260 – A300	1	42	36	13
	3R	36	36	10
	4	36	36	10
	4X Stainless	36	36	12
	4X Plastic	40	30	12
12	36	36	10	
A400 – A460	1	48	36	13
	3R	48	36	12
	4	48	36	12
	4X Stainless	48	36	12
	4X Plastic	–	–	–
12	48	36	12	
A580 – A750	1	87	36	24
	3R	87	36	24
	4	87	36	24
	4X Stainless	87	36	24
	4X Plastic	–	–	–
12	87	36	24	

Part winding, breaker combination w/CCT

Starter size	Enclosure type	A	B	C
A9 – A40 (S3)	1	14	12	8
	3R	14	12	8
	4	16	12	8
	4X Stainless	16	12	8
	4X Plastic	14	12	7
12	14	12	8	
A50 – A75 (S3)	1	24	20	8
	3R	24	20	8
	4	24	20	8
	4X Stainless	24	20	8
	4X Plastic	24	16	8
12	24	20	8	
A95 – A110 (S3)	1	30	24	12
	3R	30	24	8
	4	30	24	8
	4X Stainless	30	24	8
	4X Plastic	30	30	12
12	30	24	8	
A145 (S3)	1	24	20	8
	3R	24	20	8
	4	24	20	8
	4X Stainless	24	20	8
	4X Plastic	30	20	12
12	24	20	8	
A185 (S3, S4)	1	30	24	12
	3R	30	20	8
	4	30	20	8
	4X Stainless	30	24	8
	4X Plastic	30	20	12
12	30	20	8	
A210 – A300 (S4, S5)	1	30	24	12
	3R	30	24	10
	4	30	24	10
	4X Stainless	30	24	12
	4X Plastic	33	25	12
12	30	24	10	
A300 (S6)	1	36	30	12
	3R	30	30	10
	4	30	30	10
	4X Stainless	36	30	12
	4X Plastic	40	30	14
12	30	30	10	
A400 – A580 (S6, S7)	1	42	30	13
	3R	42	36	12
	4	42	30	12
	4X Stainless	42	30	12
	4X Plastic	–	–	–
12	42	36	12	
A750 (S7)	1	48	36	17
	3R	48	36	16
	4	48	36	16
	4X Stainless	48	36	16
	4X Plastic	–	–	–
12	48	36	16	

