

# Type PEB Power electronic brakes



## Softstarters Power electronic brakes Type PEB



6

### Description

Electronic braking stops the load by injecting a controlled amount of DC current into a three phase AC motor. The Power Electronic Brake (PEB) Series features full-wave DC braking which can be adjusted to stop your load quickly, repeatedly and reliably... even if load conditions change.

Unlike other brakes that only provide voltage control, the PEB Series is a current regulated brake. It automatically adjusts for resistance changes in the motor windings due to any input voltage fluctuations. What does this mean? Repeatable, reliable operation every time you stop your motor.

An exceptionally accurate method of micro-processor controlled sensing determines when

the motor shaft has come to a stop. Braking current is removed when the motor stops, eliminating excess braking current which means longer motor life.

Built-in jogging circuitry allows you to select the time you need for machine setup and positioning without applying DC current to the motor windings. DC current is only applied when system setup is complete... no excess current, no excess heating, no premature motor failure.

The PEB Series has a built-in feature to control a mechanical holding brake. Any fault indication automatically enables the mechanical brake for fail-safe operation.

The PEB Series has been designed and tested to meet the most stringent industry standards: UL & cUL.

UL File # E169883



## General information

### Catalog number explanation

**PEB - 010 - 48 - 1**

**Maximum brake amps**

010 - 10  
024 - 24  
050 - 50  
100 - 100  
200 - 200  
300 - 300  
400 - 400  
550 - 550  
800 - 800  
1000 - 1000

**6**

**Enclosure**

No digit - Open chassis  
1 - NEMA 1  
2 - NEMA 12  
3 - NEMA 3R  
4 - NEMA 4  
X - NEMA 4X

**Voltage**

24 - 208/240  
48 - 480  
60 - 600

# Power electronic brakes

## Open



6

Max amps ①	208V			240V			480V			600V			List price
	Horsepower		Catalog number	Horsepower		Catalog number	Horsepower		Catalog number	Horsepower		Catalog number	
	Std. duty	Hvy. duty		Std. duty	Hvy. duty		Std. duty	Hvy. duty		Std. duty	Hvy. duty		
10	3	1	PEB-010-24	3	1	PEB-010-24	7.5	3	PEB-010-48	10	5	PEB-010-60	\$ 755
24	7.5	3	PEB-024-24	10	5	PEB-024-24	20	10	PEB-024-48	25	15	PEB-024-60	1070
50	15	7.5	PEB-050-24	20	10	PEB-050-24	40	25	PEB-050-48	50	30	PEB-050-60	1450
100	30	20	PEB-100-24	40	15	PEB-100-24	75	50	PEB-100-48	100	60	PEB-100-60	2250
200	75	40	PEB-200-24	75	50	PEB-200-24	150	100	PEB-200-48	200	125	PEB-200-60	3900
300	100	60	PEB-300-24	125	75	PEB-300-24	250	150	PEB-300-48	300	200	PEB-300-60	4300
400	150	75	PEB-400-24	150	100	PEB-400-24	350	200	PEB-400-48	400	250	PEB-400-60	6500
550	250	125	PEB-550-24	200	150	PEB-550-24	500	300	PEB-550-48	600	350	PEB-550-60	8700
800	350	200	PEB-800-24	350	200	PEB-800-24	700	450	PEB-800-48	900	500	PEB-800-60	10,250
1000	400	250	PEB-1000-24	400	300	PEB-1000-24	900	500	PEB-1000-48	1000	600	PEB-1000-60	13,000

NOTE: If duty cycle is not known, it is recommended to use the heavy duty brake since braking current can be adjusted down to meet actual load requirements.

① Never exceed the motor FLA without checking the motor manufacturers data with regards to application duty cycle.

## Power electronic brakes Enclosed, NEMA 1

6

Maximum Amps FLA	Maximum motor HP ratings								NEMA 1, 480V Catalog number	NEMA 1, 600V Catalog number	List price
	208V		240V		480V		600V				
	Standard Duty	Heavy Duty	Standard Duty	Heavy Duty	Standard Duty	Heavy Duty	Standard Duty	Heavy Duty			
10	3	1	3	1	7.5	3	10	5	PEB-010-48-1	PEB-010-60-1	<b>\$ 805</b>
24	7.5	3	10	5	20	10	25	15	PEB-024-48-1	PEB-024-60-1	<b>1120</b>
50	15	7.5	20	10	40	25	50	30	PEB-050-48-1	PEB-050-60-1	<b>1650</b>
100	30	20	40	15	75	50	100	60	PEB-100-48-1	PEB-100-60-1	<b>2450</b>
200	75	40	75	50	150	100	200	125	PEB-200-48-1	PEB-200-60-1	<b>4320</b>
300	100	60	125	75	250	150	300	200	PEB-300-48-1	PEB-300-60-1	<b>4800</b>
400	150	75	150	100	350	200	400	250	PEB-400-48-1	PEB-400-60-1	<b>7000</b>
550	250	125	200	150	500	300	600	350	PEB-550-48-1	PEB-550-60-1	<b>9200</b>
800	350	200	350	200	700	450	900	500	PEB-800-48-1	PEB-800-60-1	<b>10,750</b>
1000	400	250	400	300	900	500	1000	600	PEB-1000-48-1	PEB-1000-60-1	<b>13,500</b>

NOTE: See below for additional enclosure styles and price adders.

### Options ①

Model number	NEMA 12	NEMA 3R	NEMA 4	NEMA 4X
PEB-010	<b>\$ 100</b>	<b>\$ 100</b>	<b>\$ 150</b>	<b>\$ 450</b>
PEB-024	<b>100</b>	<b>100</b>	<b>150</b>	<b>450</b>
PEB-050	<b>100</b>	<b>100</b>	<b>150</b>	<b>450</b>
PEB-100	<b>100</b>	<b>100</b>	<b>150</b>	<b>450</b>
PEB-200	<b>150</b>	<b>150</b>	<b>200</b>	<b>600</b>
PEB-300	<b>300</b>	<b>300</b>	<b>350</b>	<b>1050</b>
PEB-400	<b>300</b>	<b>300</b>	<b>350</b>	<b>1050</b>
PEB-550	<b>300</b>	<b>300</b>	<b>350</b>	<b>1050</b>
PEB-800	<b>300</b>	<b>300</b>	<b>350</b>	<b>1050</b>
PEB-1000	<b>300</b>	<b>300</b>	<b>350</b>	<b>1050</b>

① Add to list price of NEMA 1 enclosed products and change part number appropriately.

## Technical data



Item	Specification
Voltage rating	Models rated from 208 - 600V $\pm 10\%$ Selectable for 50/60Hz $\pm 2$ Hz
Current ratings	10 - 1000A in 10 sizes: 10, 24, 50, 100, 200, 300, 400, 550, 800, 1000A
Output capacity	25% duty cycle at 100% unit rating
Power circuit	Full wave bridge, 4 SCRs, designed for use without isolation contactors
Transient protection	RC snubber dv/dt circuit on each SCR device
Fusing	Approved for use with existing motor starter fusing when unit is sized for motor FLA. Consult NEC for any other fusing requirements.
Control circuit	Self-powered directly from line terminals. No separate control voltage required
Control method	Microprocessor unit controls sequencing, I/O monitoring and status annunciation. Braking current is adjustable via true RMS regulated control using phase angle firing of SCRs.
Operator adjustments	Brake Time and Jog Time = 7 position binary dipswitch Brake Current = potentiometer
Adjustment ranges	Brake Jog Times = 0 - 127 seconds in 1 sec. increments Brake Current = Up to 100% unit rating
Inputs	Starter Monitor = Dry input for auxiliary contact from motor starter. Jumper selectable for N.O. or N.C. contact.  Brake Disable = Dry input for N.O. contact to disable braking before or during operation. Can be wired to the starter thermal overload N.O. auxiliary contact to prevent braking of overloaded motor.  Motor Power Sensor (T3) = voltage input used for sensing motor power presence in sequencing/status circuit and for zero speed sensing during braking
Outputs	Starter Coil Interlock = Two sets of FORM "C" relay contacts for use in interlocking the starter coil and/or other devices to prevent energizing as the braking power is applied.  Mechanical Brake Release = N.O. relay contact for use in controlling electro-mechanical brake as a holding brake. When the PEB Series is "disabled," this circuit controls the mechanical brake normally as if it is the only brake in the system.
Auxilliary contact ratings	5 amps, 250VAC max
LED Status indicators	Large LEDs: Braking = green; Fault = red Small LEDs: Power On, Jog/Armed, Brake Off, Disabled, Over Temp, and Wiring Error
Operating design temperature	0 - 50 °C (32-122 °F) open 0 - 40 °C (32 - 104 °F) enclosed
Ambient conditions	0 - 95% relative humidity 0 - 3300ft (1000M) elevation
Approvals	UL, cUL Listed

6

## Approximate dimensions & Circuit diagram

### Open

#### Approximate dimensions (inches)

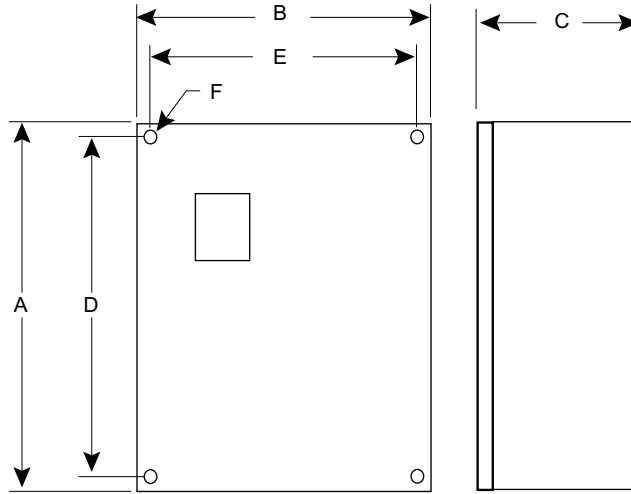

Model No.	A	B	C	D	E	F
PEB-10	8.5	7.3	6.2	8	6.9	0.21
PEB-24	8.5	7.3	6.2	8	6.9	0.21
PEB-50	10.5	7.9	7.2	10	6.8	0.22
PEB-100	10.5	7.9	7.2	10	6.8	0.22
PEB-200	16.5	10	10	15.9	9	0.28
PEB-300	16	16	10	15	15	0.5
PEB-400	16	16	10	15	15	0.5
PEB-550	16	16	10	15	15	0.5
PEB-800	16	16	10	15	15	0.5
PEB-1000	16	16	10	15	15	0.5

#### Circuit diagram

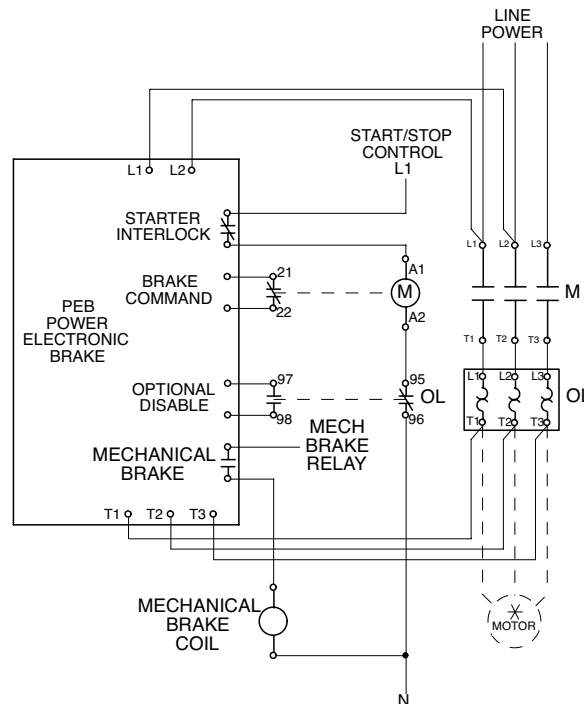

# Approximate dimensions & Circuit diagram Enclosed



## Approximate dimensions (inches) ①

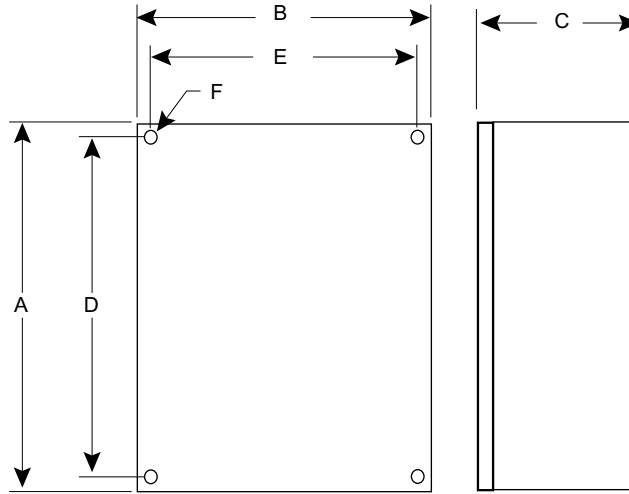

Model No.	A	B	C	D	E	F
PEB-10	16	12	9	14.5	10.5	0.5
PEB-24	16	12	9	14.5	10.5	0.5
PEB-50	20	16	9	18.5	14.5	0.5
PEB-100	20	16	9	18.5	14.5	0.5
PEB-200	24	20	13	22.5	18.5	0.5
PEB-300	36	24	13	34.5	22.5	0.5
PEB-400	36	24	13	34.5	22.5	0.5
PEB-550	36	24	13	34.5	22.5	0.5
PEB-800	36	24	13	34.5	22.5	0.5
PEB-1000	36	24	13	34.5	22.5	0.5

## Circuit diagram

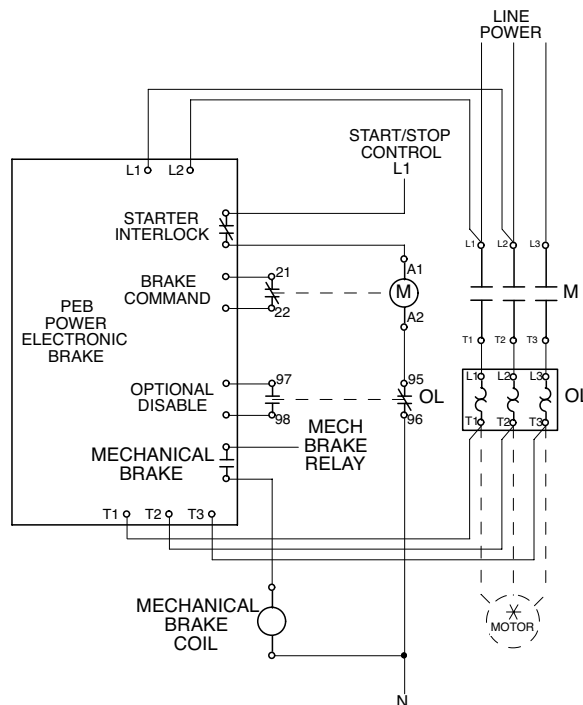

① Dimensions apply to NEMA 1, NEMA 12, NEMA 3R and NEMA 4 enclosures. Consult factory for NEMA 4X dimensions.



## Notes