

Type N, NE, NL & TNL Control relays



Control relays

Type N, NE, NL & TNL

Positive safety

AC/DC operated

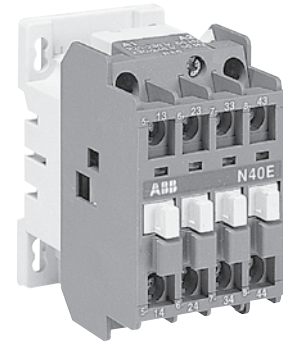

7

Description

There are many applications where safety is very critical and it is important to use electrical equipment which ensures that dangerous machine movement cannot occur when a fault is detected with the moving contacts during the cycle which the fault is indicated.

Regulations and standards have been written to ensure that safety is maintained:

- United States ANSI B11.19-1990
 ANSI B11.20-1991
- Germany SÜVA
 ZH1/457
- France INRS
- United Kingdom BIA
- Switzerland SA

The ABB Type N & NL 4 and 8 pole relays are designed with “Positive Guided” contacts and fulfill the regulations or standards shown.

The relays can provide positive safety for the N.O. and N.C. contacts which assure that the N.O. contacts will not close before any N.C. contact opens. Therefore, if one of the contacts weld due to abnormal conditions in the control circuit, the other contacts will also remain in the same position as when the welding occurred. This means that the open contacts must maintain an air distance 0.5mm when the coil is energized at 110% Vc or when it is de-energized.

UL File No: E39231 (N & NL)

General information

Type N, AC operated

Description

- AC operated with laminated magnetic circuit.
- 2 versions: 4 pole or 8 pole. The width of 8 pole devices is identical to that of 4 pole devices; only the depth is increased.
- Side by side mounting possible.
- Self cleaning auxiliary contacts.
- Alone or by itself or with a 4 pole CA5 auxiliary contact block, these devices offer "positive safety" between their auxiliary contacts.

Application

Type N control relays are used for switching auxiliary circuits and control circuits.

7

Holes for screw mounting (screws not supplied). Distances between holes according to EN50 002.

Quick mounting on 35 x 7.5mm DIN mounting rail according to IEC715 and EN50 022.

Location of side mounted accessories: mounting on right or left hand side.

Terminals delivered in open position with captive screws (screws of unused terminals should be tightened).

Screwdriver guidance for all screws makes it possible to use motorized screwdrivers.

All terminals provide protection against accidental direct contact with live parts according to VDE0106 – Part. 100 and offer IP 20 degree of protection according to IEC947-1.

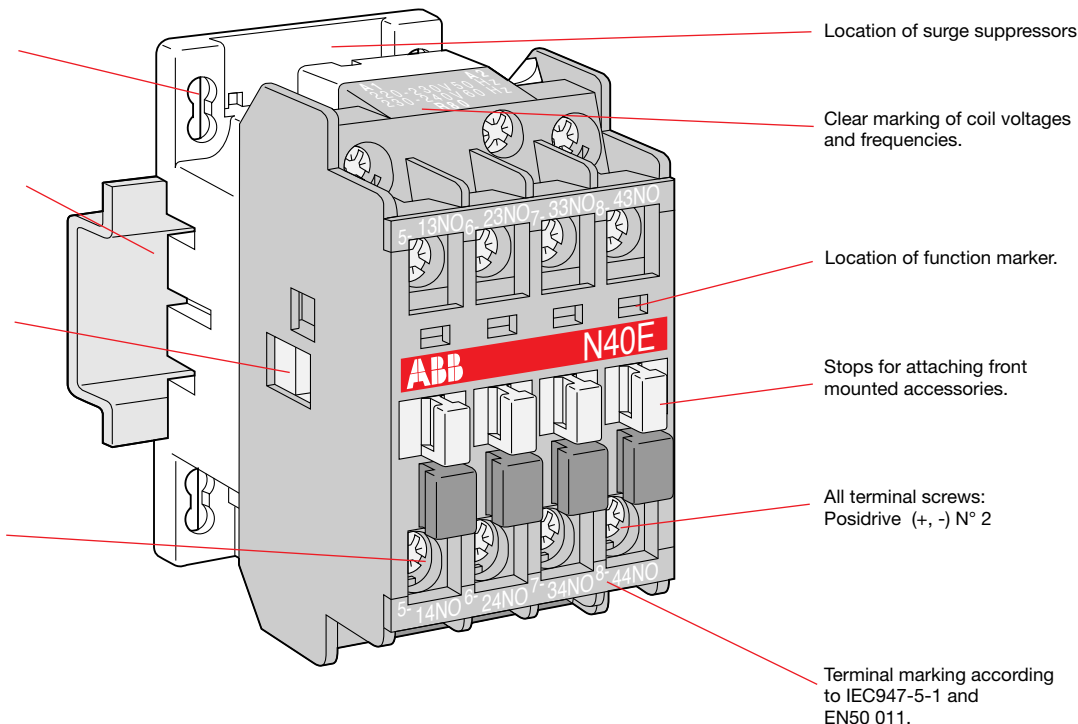

Catalog number explanation

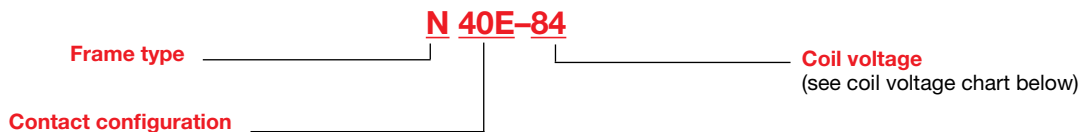

Coil voltage selection chart

Hz	Relay type	Volts															
		12	24	48	110	120	125	208	220	240	277	380	415	440	480	500	600
60	N		81	83	84	84		34	36	80	42		86	86	51	53	55
50	N		81	83	84				80				85	86			55
DC	NE, NL	80	81	83	86		87		88	89							

General information

Type NE, DC operated

Description

- Contactor relays with laminated magnet circuit and double-winding coil fed from a DC supply via a built-in N.C. lagging auxiliary contact.
- 1-stack version with three built-in auxiliary contacts.
- Self-cleaning auxiliary contacts
- Alone or fitted with a 4-pole CA5 auxiliary contact block, these devices offer mechanically linked contacts.
- Side by side mounting possible.

Application

NE... contactor relays are used for switching auxiliary circuits and control circuits.

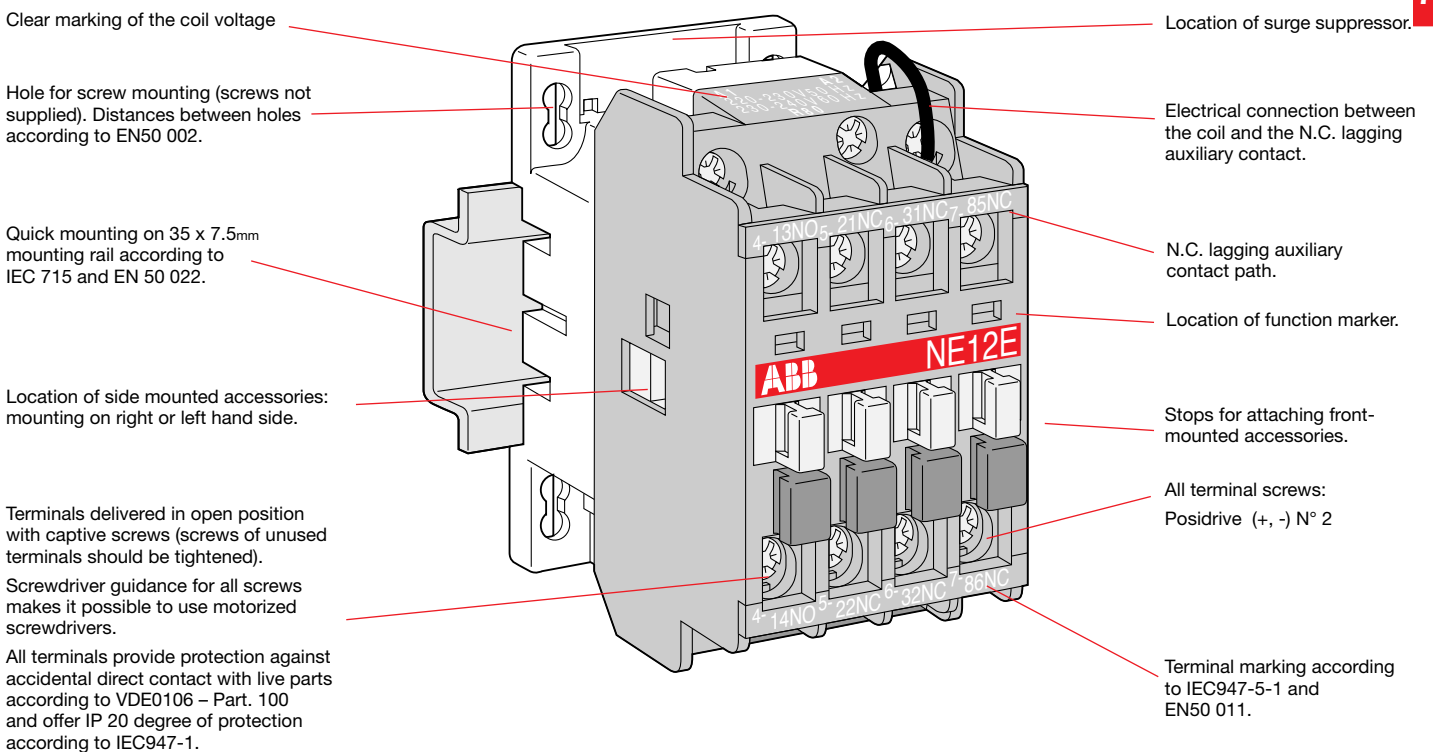

Catalog number explanation

NE 12E-84



Coil voltage selection chart

Hz	Relay type	Volts															
		12	24	48	110	120	125	208	220	240	277	380	415	440	480	500	600
60	N		81	83	84	84		34	36	80	42		86	86	51	53	55
50	N		81	83	84				80			85	86			55	
DC	NE, NL	80	81	83	86		87		88	89							

General information

Type NL & TNL, DC operated

Type NL

Description

- Magnetic circuit variants: NL types: d.c. operated with solid magnetic circuits.
- 2 versions: 4 pole or 8 pole
The width of 8 pole devices is identical to that of 4 pole devices; only the depth is increased.
- Bifurcated auxiliary contacts.
- Alone or mounted with a 4 pole CA5 auxiliary contact block, these devices offer "positive safety" between their auxiliary contacts.

Application

Type NL relays are used for switching auxiliary circuits and control circuits.

Type TNL

Description

- Magnetic circuit variants
 - NL types: D.C. operated with solid magnetic circuits.
 - TNL types: D.C. operated with solid magnetic circuit and large coil voltage range.
- 2 versions
 - 4-pole/1-stack or 8-pole/2-stack
 - The width of 8-pole devices is identical to that of 4 pole devices; only the depth is increased.
- Double sharp auxiliary contacts.
- Alone or mounted with a 4-pole CA 5 auxiliary contact block, these devices offer "positive safety" between their auxiliary contacts.

Application

Type NL and TNL control relays are used for switching auxiliary circuits and control circuits.

7

Location of surge suppressors.

Quick mounting on 35 x 7.5mm or 35 x 15mm DIN mounting rail according to IEC947-5-1 and EN50022.

Holes for screw mounting (screws not supplied). Distances between holes according to EN50002.

Terminals delivered in open position with captive screws (screws of unused terminal should be tightened).

Screwdriver guidance for all screws makes it possible to use motorized screwdrivers.

All terminals provide protection against accidental direct contact with live parts according to VDE0106 – Part. 100.

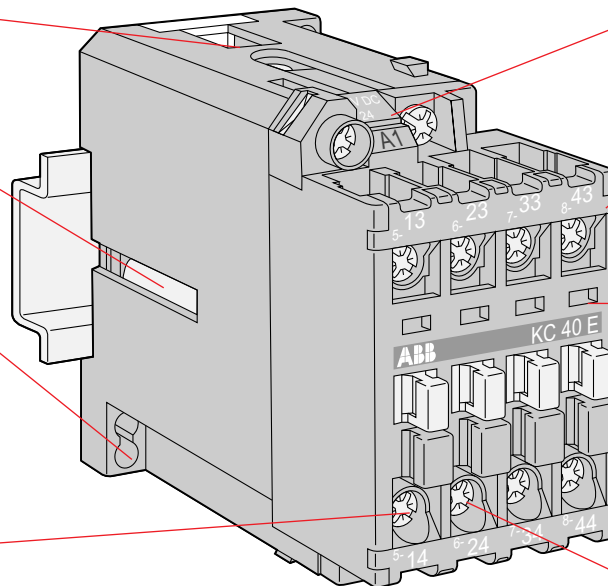

Clear marking of coil voltages.

Terminal marking according to IEC947-5-1 and EN50 011.

Location of function marker and surge suppressor.

Stops for attaching front mounted accessories.

All terminal screws: M 3.5, posidrive (+,-) N° 2

Catalog number explanation

(T)NL 44E-84

Frame type

Coil voltage

(see coil voltage chart below.)

Contact configuration

Coil voltage selection chart

Hz	Relay type	Volts															
		12	24	48	110	120	125	208	220	240	277	380	415	440	480	500	600
60	N		81	83	84	84		34	36	80	42		86	86	51	53	55
50	N		81	83	84				80				85	86			55
DC	NE, NL	80	81	83	86		87		88	89							

Type N & NL AC & DC operated



N40E-1



NE12E-1

A.C. operated

Contact configuration		Catalog number	List price
N.O.	N.C.		
4	0	N40E-84	\$ 60
3	1	N31E-84	
2	2	N22E-84	
4	4	N44E-84	120
5	3	N53E-84	
6	2	N62E-84	
7	1	N71E-84	
8	0	N80E-84	

Coil voltage selection

All AC operated catalog numbers include a 120VAC coil. All DC operated catalog numbers include a 110VDC coil. To select other coil voltages, substitute the code from the Coil Voltage Selection Chart for the first digit after the last dash in the catalog number.

Ex.: A 240V coil is required for an N80 control relay: N80E-80

Coil voltage selection chart

Hz	Relay type	Volts																
		12	24	48	110	120	125	208	220	240	277	380	415	440	480	500	600	
60	N		81	83	84	84		34	36	80	42		86	86	51	53	55	
50	N		81	83	84				80			85	86			55		
DC	NE, NL	80	81	83	86		87		88	89								

D.C. operated

Contact configuration		Catalog number	List price
N.O.	N.C.		
4	0	NL40E-86	\$ 72
3	1	NL31E-86	
2	2	NL22E-86	
4	4	NL44E-86 ①	144
5	3	NL53E-86 ①	
6	2	NL62E-86 ①	
7	1	NL71E-86	
8	0	NL80E-86	
1	2	NE12E-86	72
2	1	NE21E-86	
3	0	NE30E-86	
4	3	NE43E-86 ①	144
5	2	NE52E-86 ①	
6	1	NE61E-86 ①	
7	0	NE70E-86 ①	

Block diagrams for NE... contactor relay coil supply

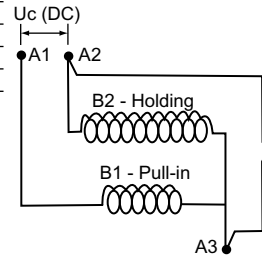

Coil supply $U_c < 110$ VDC

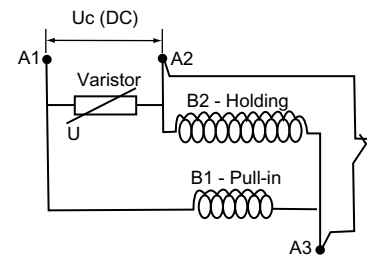

Coil supply via built-in varistor $U_c \leq 110$ VDC

① NE43 – NE70 and NL44 – NL62 control relays cannot accept any front mounted auxiliary contact blocks.

Type TNL 4 Pole & 8 Pole



TNL22E

4 Pole, 1 stack

Number of contacts		Weight	Catalog number	List price	
1st stack					2nd stack
N.O.	N.C.	N.O.	N.C.		
2	2	-	-	0.540	TNL22E-Δ
3	1	-	-	0.540	TNL31E-Δ
4	-	-	-	0.540	TNL40E-Δ

8 Pole, 2 stack

Number of contacts		Weight	Catalog number	List price	
1st stack					2nd stack
N.O.	N.C.	N.O.	N.C.		
4	-	-	4	0.600	TNL44E-Δ
4	-	2	2	0.600	TNL62E-Δ

Δ - Substitute the Δ for the coil voltage code. See the Type TNL Coil voltage Selection chart beneath the photos.

Coil characteristics

No extra tolerances applicable to the U_c min. ... max. values quoted in the Coil voltage selection table

- Coil consumption at U_c max. $q = 20^\circ\text{C}$: 9 W pull-in/holding
- Replacement coils: consult us (standard coils used on NL control relays are not suitable for TNL control relays).

Coil voltage selection

Min.	U_c	Max	Voltage
17	-	32	51
24	-	45	52
36	-	65	54
42	-	78	58
50	-	90	55
77	-	143	62
90	-	150	66
152	-	264	68

Mounting distance – for coil operating limits U_c min. ... U_c max.

A mm	B mm	Ambient temp. $^\circ\text{C}$	Max. switching frequency Operating cycles/h
2	20	≤ 20	1200
5	20	≤ 55	1200

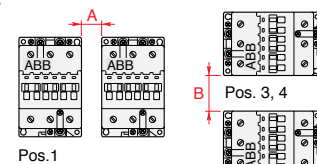

Add-on accessories

Control relays	Max. number of auxiliary contact blocks						Timer TP	Mechanical interlock	Label marker
	CA5-10	CA5-01	CA5-40	CA5-31	CA5-22	CA5-04			
Pos. 1, 3 or 4 TNL 40-E	4	2	1	1	1	-	-	VBC 30	BA 5-50
Pos. 1, 3 or 4 TNL 31-E	4	1	1	1	-	-	-	VBC 30	BA 5-50
Pos. 1, 3 or 4 TNL 22-E	4	-	1	-	-	-	-	VBC 30	BA 5-50
Pos. 1 $\pm 30^\circ$ TNL - all types	-	-	-	-	-	-	-	VBC 30	BA 5-50

Mounting positions

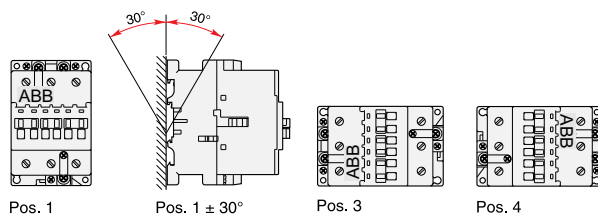

Accessories

Type N, NL & TNL

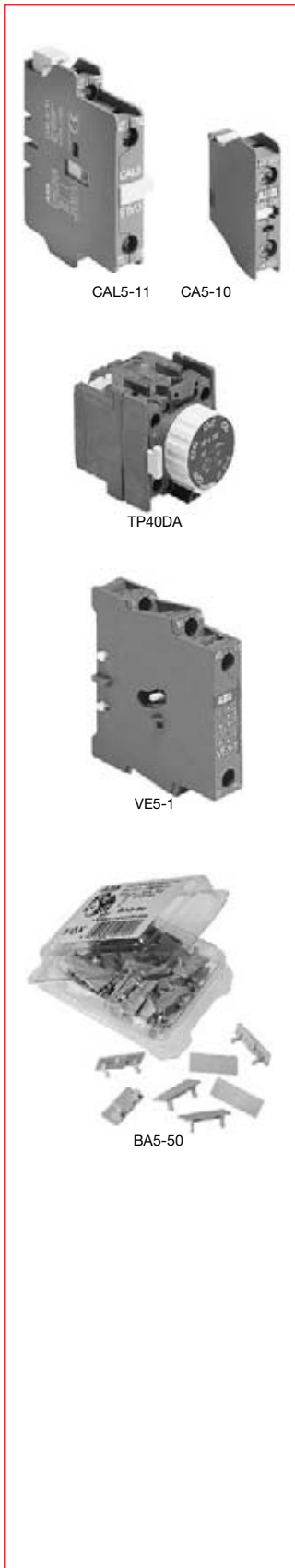

Auxiliary contact blocks

Positioning	Contacts		Catalog number	List price
	N.O.	N.C.		
N, NE, NL, TNL (front mount)	1	—	CA5-10 CA5-01	\$ 15
	—	1		
N, NL, NE, TNL (4 pole)	4	—	CA5-40N CA5-22N CA5-04N	30
	2	2		
	—	4		
N, NE, NL, TNL (side mount)	1	1	CAL5-11	

Pneumatic timers

Timing range	Contacts		Catalog number	List price
	N.O.	N.C.		
N, NL On delay 0.1 – 40s	1	1	TP40DA TP180DA TP40IA TP180IA	\$ 108
	1	1		
NE, TNL Off delay 0.1 – 40s	1	1		
	1	1		

Interlocks

Feature	Contacts		Catalog number	List price
	N.O.	N.C.		
N, NE, NL, TNL Mechanical/electrical	—	2	VE5-1	\$ 45
N, NE, NL, TNL Mechanical	—	—	VM5-1	21

Mechanical latches

Feature	Catalog number	List price
N, NL (4 pole only)	WB75A-Δ	\$ 84

Coil voltage selection chart – mechanical latches

50 Hz	60 Hz	Voltage code
24	24 – 28	01
42	42 – 48	02
48	48 – 55	03
110	110 – 127	04
220 – 230	220 – 255	06
230 – 240	230 – 277	05
380 – 415	380 – 440	07
415 – 440	440 – 480	08

Identification markers

Feature	Catalog number	List price
Pack of 50	BA5-50	\$ 15

7

Accessories

Type N, NL, NE & TNL



ZA16-84



RV5/50

RC5-1/50

Coils

Relay type	Catalog number	List price
N	ZA16-Δ	\$ 24
NE	ZAE16-Δ	24

Δ Select the coil voltage from the Control Relay Coil Voltage Selection chart and substitute the letter code for the Δ as the last digit in the catalog number.

Coil voltage selection chart

Hz	Relay type	Volts															
		12	24	48	110	120	125	208	220	240	277	380	415	440	480	500	600
60	N		81	83	84	84		34	36	80	42		86	86	51	53	55
50	N		81	83	84				80			85	86			55	
DC	NE, NL	80	81	83	86		87		88	89							

Surge suppressors — for Type N control relays

Feature	Type	Voltage range	Catalog number	List price
Varistor	N, NE NL, TNL	24 – 50 VAC/DC	RV5/50	\$ 30
		50 – 133 VAC/DC	RV5/133	
		110 – 250 VAC/DC	RV5/250	
		250 – 440 VAC/DC	RV5/440	
RC	N	24 – 50 VAC	RC5-1/50	\$ 30
		50 – 133 VAC	RC5-1/133	
		110 – 250 VAC	RC5-1/250	
		250 – 440 VAC	RC5-1/440	

Technical data

Type	Control circuit	Opening time growth factor	Residual overvoltage or clipping voltage	Remarks	
RV5/... ing	AC/DC	1.1 to 1.5	132V	Advantages	
				Disadvantages	• Good energy absorption & damp-
					• Unpolarized system
					• Clipping from U_{vdr} thus voltage front up to this point
RC5-1/... or RC5-2/... RC-EH300/...	AC	1.2 to 3	2 to 3 x U_c	Advantages	
				• Very fast clipping	
				• Attenuation of steep fronts and therefore, high frequencies	
				• No operating delays	

Accessory mounting information

Type N, NE, NL & TNL

4 Pole, N control relays

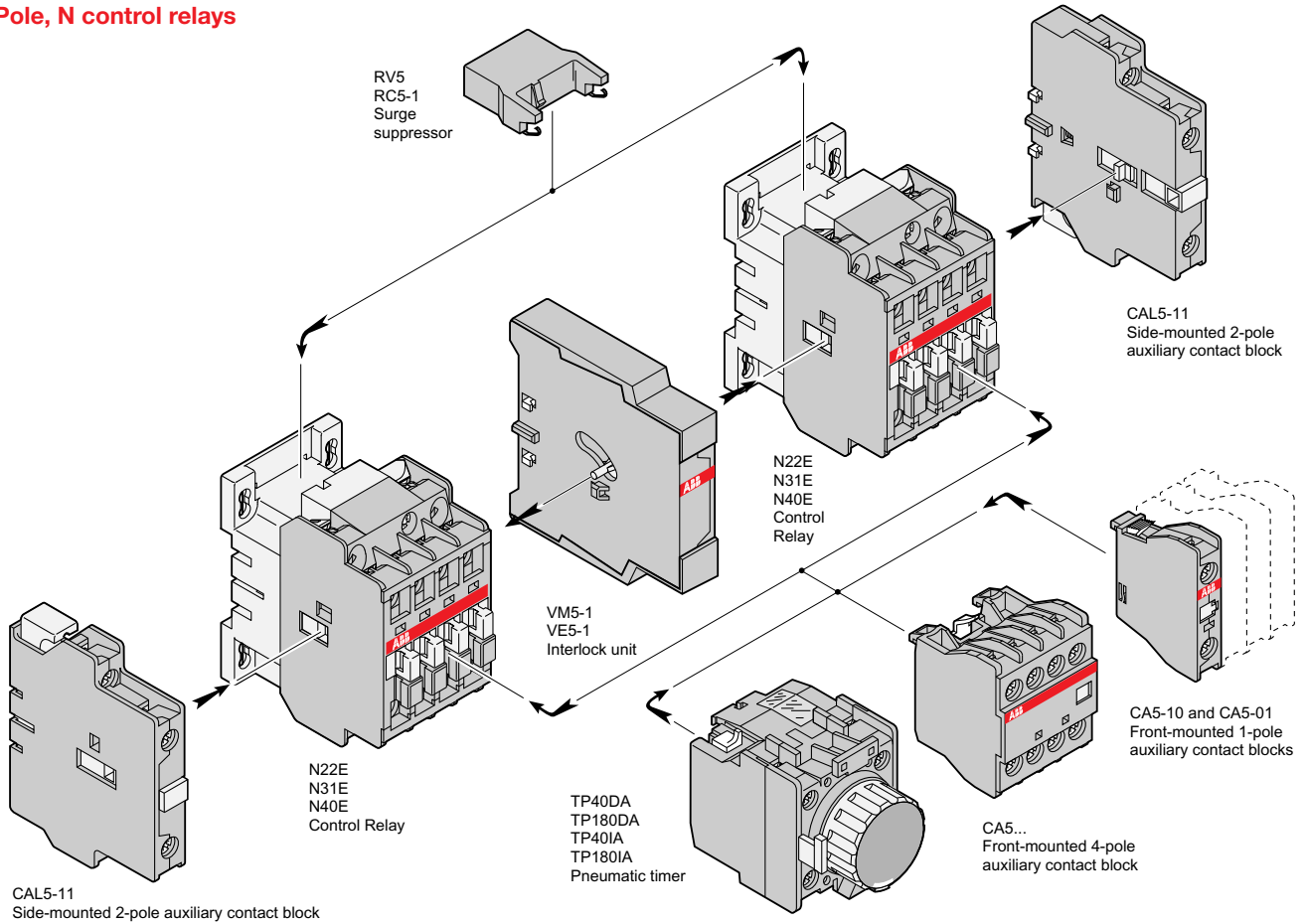



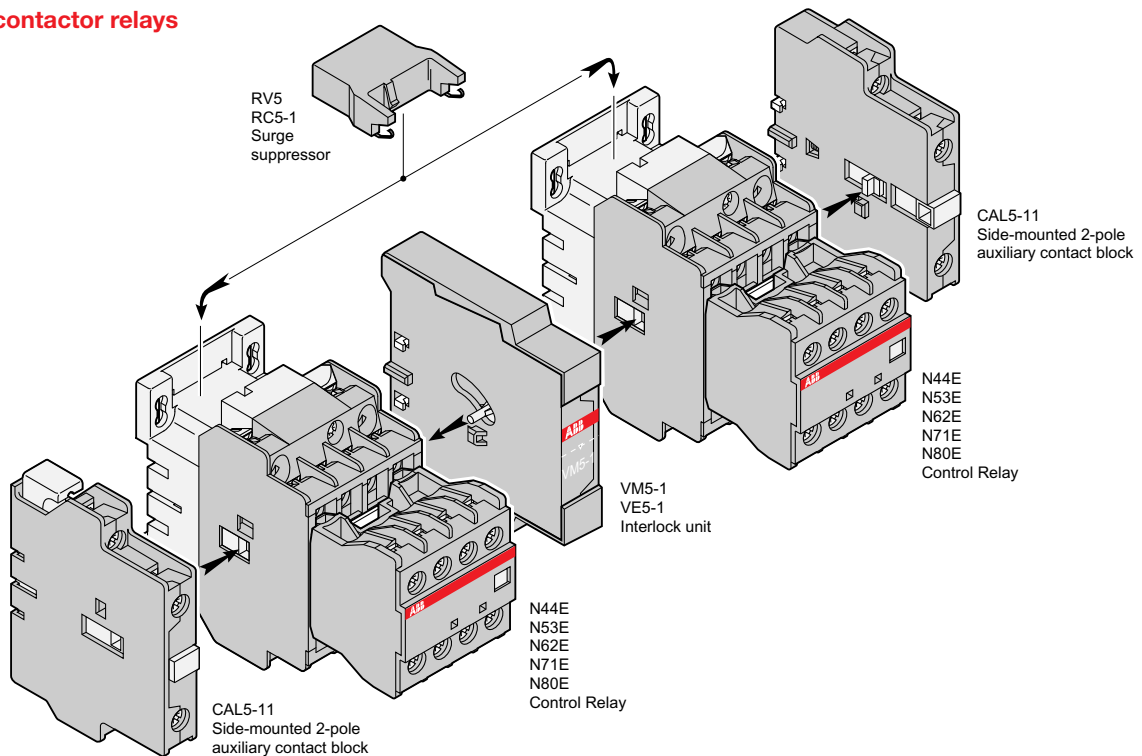











8 Pole, N contactor relays



Possible accessory combinations Type N, NE, NL, TNL

Configurations of accessories are different depending on whether front or side mounted.

Type	Main poles	Built-in auxiliary contacts	Accessories — Front mounting			Accessories — Side mounting	
			Auxiliary contact blocks 1-pole CA5-	4-pole CA5-	TP - A Pneumatic timer block	Auxiliary contact Blocks 2-pole CAL5-11	Interlock units
N	2	2 E					
N	3	1 E	1 to 4 CA5- 1-pole blocks	1 CA5- 4-pole block	1 TP - A block	+ 1 to 2 CAL5-11 blocks	1 VM/ε5-1 block + 1 CAL5-11 block
N	4	0 E					
N	4	4 E					
N	5	3 E					
N	6	2 E	—	—	—	+ 1 to 2 CAL5-11 blocks	1 VM/ε5-1 block + 1 CAL5-11 block
N	7	1 E					
N	8	0 E					
NE	2	2 E					
NE	3	1 E	1 to 4 CA5- 1-pole blocks	1 CA5- 4-pole block	1 TP - A block	+ 1 to 2 CAL5-11 blocks	1 VM/ε5-1 block + 1 CAL5-11 block
NE	4	0 E					
NE	4	4 E					
NE	5	3 E					
NE	6	2 E	—	—	—	+ 1 to 2 CAL5-11 blocks	1 VM/ε5-1 block + 1 CAL5-11 block
NE	7	1 E					
NE	8	0 E					
NL	2	2 E			—	1 CAL5-11 block	1 VM/ε5-1 block + 1 CAL5-11 block
NL	3	1 E	1 to 4 CA5- 1-pole blocks	1 CA5- 4-pole block	—	1 CAL5-11 block	1 VM/ε5-1 block + 1 CAL5-11 block
NL	4	0 E					
NL	4	4 E					
NL	5	3 E					
NL	6	2 E	—	—	—	or 1 CAL5-11 block	1 VM/ε5-1 block + 1 CAL5-11 block
NL	7	1 E					
NL	8	0 E					
TNL	2	2 E			—	1 CAL5-11 block	1 VM/ε5-1 block + 1 CAL5-11 block
TNL	3	1 E	1 to 4 CA5- 1-pole blocks	1 CA5- 4-pole block	—	1 CAL5-11 block	1 VM/ε5-1 block + 1 CAL5-11 block
TNL	4	0 E					
TNL	4	4 E					
TNL	5	3 E					
TNL	6	2 E	—	—	—	or 1 CAL5-11 block	1 VM/ε5-1 block + 1 CAL5-11 block
TNL	7	1 E					
TNL	8	0 E					

Technical data

UL & CSA

AC inductive ratings – NEMA A600

Voltage	Continuous current	Maximum make	Maximum break
120V 240V 480V 600V	10	7200VA	720VA

AC coil consumption

In rush	Sealed
80VA	8VA

AC operating time

Pickup	Dropout
10 – 20ms	10 – 20ms

AC mechanical endurance

30 million operations

DC inductive ratings – NEMA P300

Voltage	Continuous current	Maximum make	Maximum break
120V 250V 300-600V	5	138VA	138VA

DC coil consumption

In rush	Sealed
7.0W	7.0W

DC operating time

Pickup	Dropout
30 – 90ms	10 – 20ms

DC mechanical endurance

30 million operations

Technical data

Terminal marking and positioning

Type N

N control relays

Pole configuration schematics

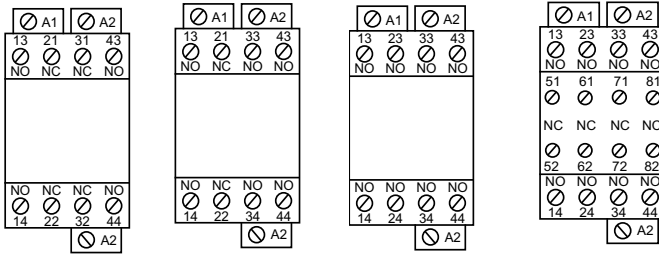

N22E **N31E** **N40E** **N44E**

4 Pole control relay

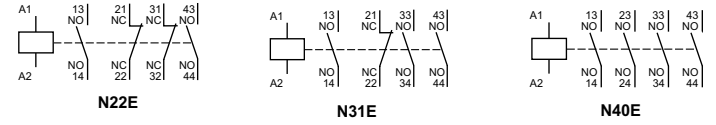

N22E **N31E** **N40E**

4 Pole control relay with 4 pole adder deck



N71E **N53E**



N62E **N44E**



N80E **N71E**

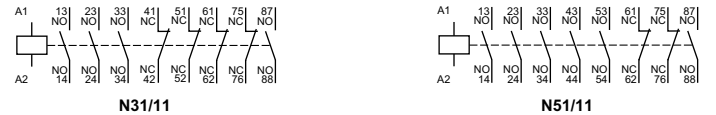

N31/11 **N51/11**

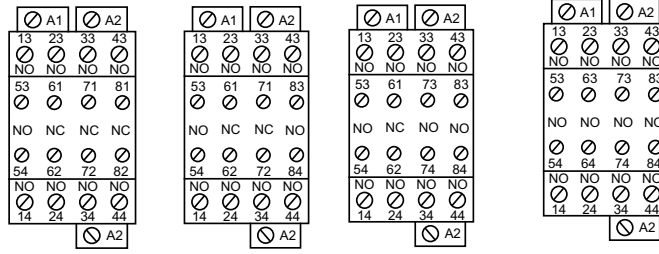

N53E **N62E** **N71E** **N80E**

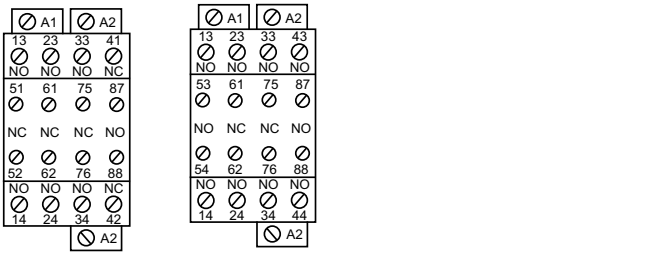

N33/11 **N51/11**

Other possible contact combinations with auxiliary contacts added by the user

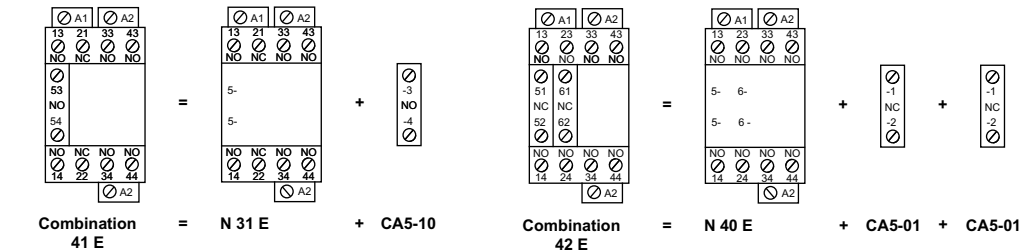

Combination 41 E = **N 31 E** + **CA5-10** + **CA5-01**
Combination 42 E = **N 40 E** + **CA5-01** + **CA5-01**

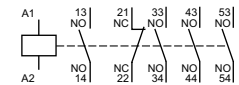

Combination 41 E

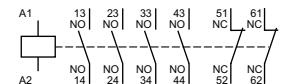

Combination 42 E

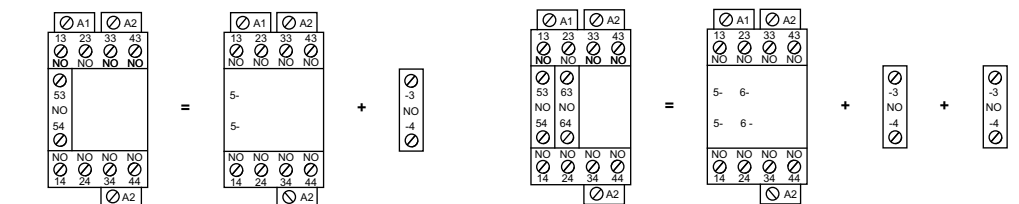

Combination 50 E = **N 40 E** + **CA5-10**
Combination 60 E = **N 40 E** + **CA5-10** + **CA5-10**



Combination 50 E

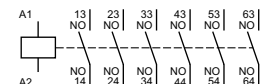

Combination 60 E

Technical data

Terminal marking and positioning

Type NE

NE control relays

Pole configuration schematics

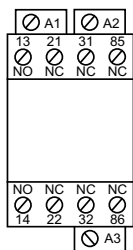

NE12E

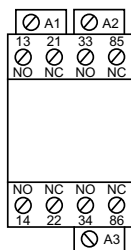

NE21E

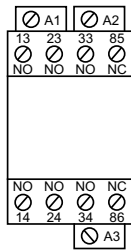

NE30E

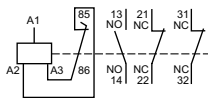

NE12E

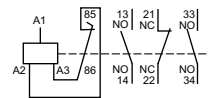

NE21E

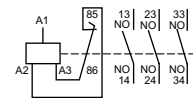

NE30E

Technical data

Terminal marking and positioning

Type NL & TNL

Standard devices without addition of auxiliary contacts

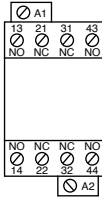

NL22E
TNL22E

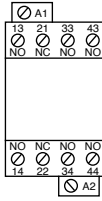

NL31E
TNL31E

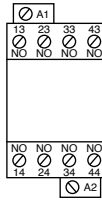

NL40E
TNL40E

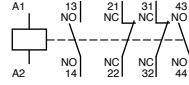

NL22E
TNL22E

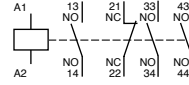

NL31E
TNL31E

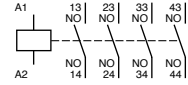

NL40E
TNL40E

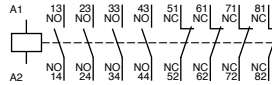

NL44E
TNL44E

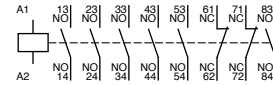

NL62E
TNL62E

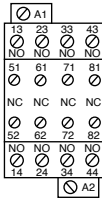

NL44E
TNL44E

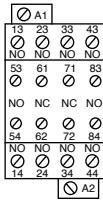

NL62E
TNL62E

Other possible contact combinations with auxiliary contacts added by the user

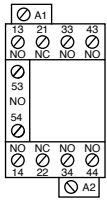

Combination 41E = NL31E
TNL31E + CA5-10
+ CA5-10

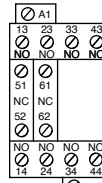
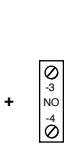
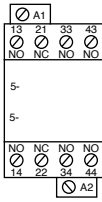

Combination 42E = NL40E
TNL40E + CA5-01 + CA5-01
+ CA5-01 + CA5-01

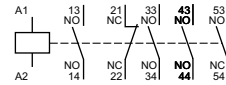
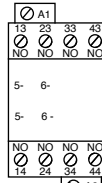

Combination 41 E

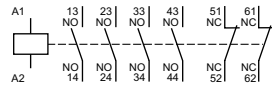

Combination 42 E

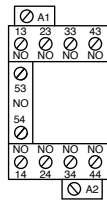

Combination 50E = NL40E
TNL40E + CA5-10
+ CA5-10

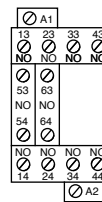
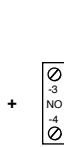
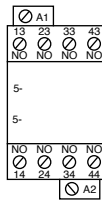

Combination 60 E = NL40E
TNL40E + CA5-10 + CA5-10
+ CA5-10 + CA5-10

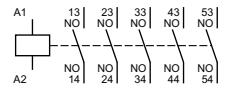
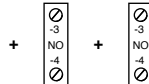
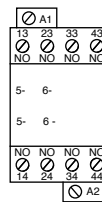

Combination 50 E

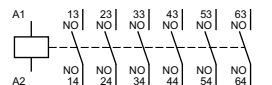

Combination 60 E

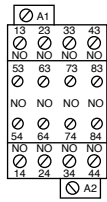

Combination 80E = NL40E
TNL40E + CA5-40E
+ CA5-40E

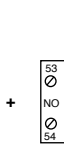
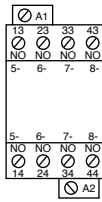

Combination 80 E

Technical data

IEC

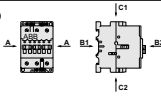
Type	NE12, NE 21, NE 30	N22, N31, N40	N44, N53, N62, N71, N80	NL22, NL31, NL40	NL44, NL62
Number of poles	3	4	8	4	8
Insulation characteristics					
Rated insulation voltage U_i acc. to IEC947-5-1 and VDE0110 (Gr. C) acc. to UL/CSA	V		690 600		
Rated impulse withstand voltage U_{imp} acc. to IEC947-5-1	kV		8		
General technical data					
Standards	Devices complying with international standards IEC947-5-1/947-4-1 and European standards EN60 947-5-1/60 947-4-1 Electromagnetic compatibility (EMC) according to amendment A11 to IEC947-1; EN60 947-1 and amendment 2 to IEC947-4-1				
Air temperature near contactor – for operation in free air: – for storage:	°C °C	-40 to +55 (0.85 – 1.1 U_o) / +55 to +70 (U_o) -60 to +80			
Climatic withstand	according to IEC68-2-30 and 68-2-11 – UTE C63-100, Specification II				
Mounting positions (see diagrams below)	Positions 1 to 5 – $\theta \leq 55^\circ\text{C}$: 0.85 – 1.1 – $\theta = 55 - 70^\circ\text{C}$:		Position 6 – $\theta \leq 55^\circ\text{C}$: 0.95 – 1.1 – $\theta > 55^\circ\text{C}$: not acceptable		
Operating altitude	m	≤ 3000			
Shock withstand according to IEC 68-2-27 and EN 60068-2-27 Mounting pos. 1 (see below)			1/2 sinusoidal shock, 11ms: no change in contact position Shock direction: A, C1, C2 : 20 g B1 : 5 g B2 : 15 g		
Mounting – on mounting rail – with screws (not supplied)	35mm according to IEC715 and EN50022 2 x M4				
Connection terminals (delivered in open position, screws of unused terminals must be tightened)	M 3.5 (+,-) posidrive 2 screw with cable clamp				
Connection capacity Rigid solid	1 x AWG 2 x AWG	16 – 12 16 – 12			
Degree of protection according to IEC529, IEC947-1 and EN60529 – Pole terminals – Coil terminals	IP20 IP20		IP20 IP20		

Mounting positions

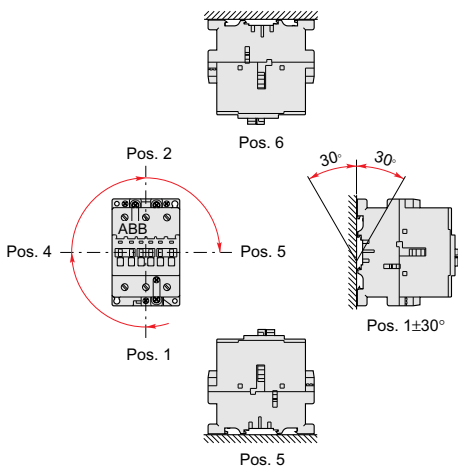

Electrical durability of contacts

utilization category AC – 15 according to IEC947-5-1

making current: 10 x

breaking current:

I_e with $\cos \phi = 0.7$ and U_e

I_e with $\cos \phi = 0.4$ and U_e

The curves opposite show the electrical durability of the control relays as well as the add-on auxiliary contact blocks in relation to the breaking current I_c . These curves have been drawn for resistive and inductive loads up to 690V, 40 – 60 Hz.

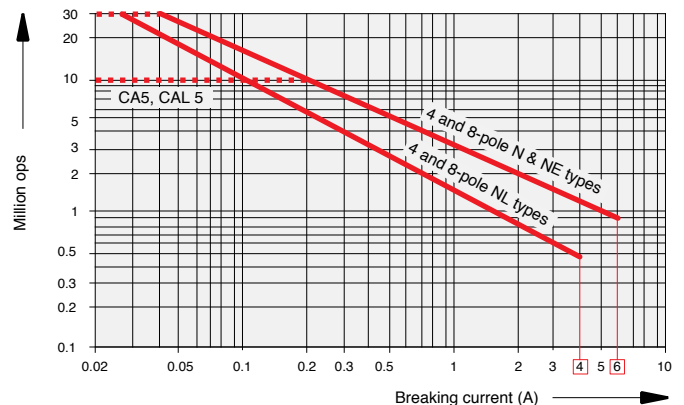

Type	NE12, NE21, NE30	N22, N31, N40	N44, N53, N62, N71, N80	NL22, NL31, NL40	NL44, NL62
Number of poles	3	4	8	4	8
Pole utilization characteristics					
Rated operational voltage U_e V	690				
Conventional thermal current in free air I_{th} according to IEC947-5-1 $\theta \leq 40^\circ\text{C}$	A	16		16	
Rated operating current I_e					
in AC-15 according to IEC947-5-1					
24 – 127 V 50/60 Hz	A	6		6	
230 – 240 V 50/60 Hz	A	4		4	
400 – 415 V 50/60 Hz	A	3		3	
500 V 50/60 Hz	A	2		2	
690 V 50/60 Hz	A	2		2	
in DC-13 according to IEC947-5-1					
24VDC	A/W	6/144		6/144	
48VDC	A/W	2.8/134		2.8/134	
72VDC	A/W	1/72		1/72	
125VDC	A/W	0.55/69		0.55/69	
250VDC	A/W	0.3/75		0.3/75	
Field of rated frequencies	Hz	25 – 400			
Mechanical durability in operating cycles		10 million	> 20 million	30 million	
Max. switching frequency	cycles/h	3000	6000	6000	
Electrical durability in operating cycles		1200			
Max. switching frequency	cycles/h	1200			
Rated making capacity according to IEC947-5-1		10 x I_e /AC-15			
Rated breaking capacity according to IEC947-5-1		10 x I_e /AC-15			
gG (gl) protection fuse	A	10			
Rated short time withstand current					
at ambient temp. of 40 °C,	1.0 s	100A		50A	
in free air, from cold state	0.1 s	140A		100A	
Insulation resistance at 500 VDC		after durability test: 5 M Ω			
Min. switching capacity		17V / 5mA		24V / 5mA	
with failure rate below 10 ⁻⁶					
Non overlapping time between N.O. and N.C. contacts	ms	≥ 2			
Power loss per pole at 6A	W	0.10		0.15	
Magnet system characteristics					
Coil operating limits $\theta \leq 40^\circ\text{C}$		according to IEC 947-5-1 : 0.85 - 1.1 U_c			
Drop out voltage in % of U_c		10 – 30%	roughly 40 – 65%	roughly 10 – 30%	
Coil consumption (average value)					
– a.c. operation: 50 Hz pull in	VA	–	70	–	
60 Hz pull in	VA	–	80	–	
50/60 Hz ^① pull in	VA/VA	–	74/70	–	
50/60Hz holding	VA/W	–	8/2	–	
– d.c. operation: cold pull in	W	90	–	3	
warm holding	W	2	–	3	
Rated control voltage U_c					
– AC operation: 50/60 Hz	V	–	20 – 690	–	
– DC operation:	VDC	12 – 250	–	12 – 240	
Max. permissible short supply interruption					
without opening of contacts	ms	2	2	2	
Operating time					
between coil energization and:					
– closing of N.O. contact	ms	10 – 16	10 – 26	100	
– opening of N.C. contact	ms	8 – 12	7 – 21	20 – 70	
between coil de energization and:					
– opening of N.O. contact	ms	5 – 14	4 – 11	10 – 17	
– closing of N.C. contact	ms	11 – 17	9 – 16	16 – 27	

① 50/60 Hz coils: voltage codes 80 to 88, see page 7.5.

Approximate dimensions

Type N, NE, NL, & TNL

AC & DC operated

00.00 Inches
00.00 [Millimeters]

Type N, 4 Pole, AC operated

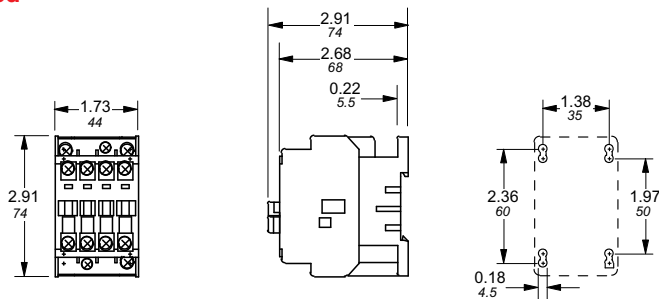

Type NE, 4 Pole, DC operated

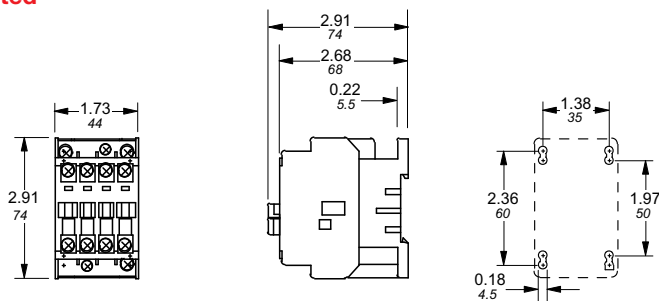

Type NL, TNL

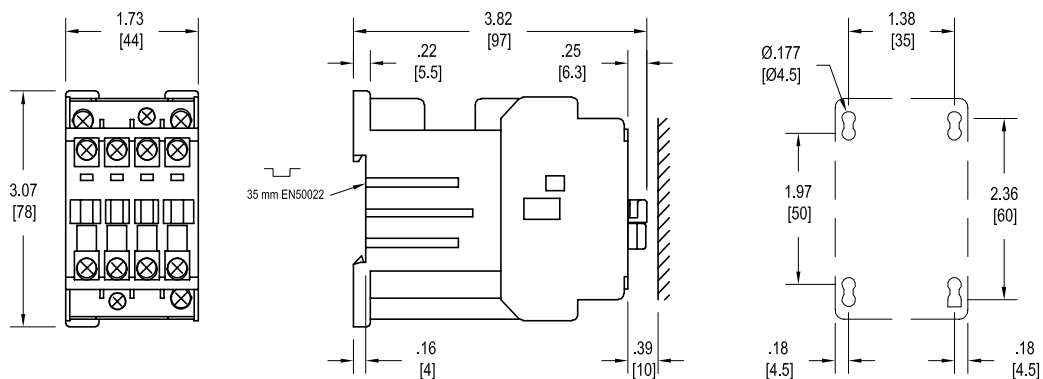

Approximate dimensions Accessories for Type N & NE

N & NE

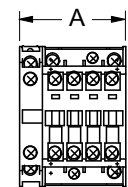

SIDE MOUNTED
AUXILIARY

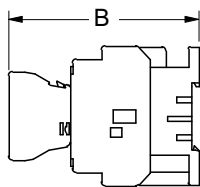

SINGLE POLE
TOP MOUNTED
AUXILIARY

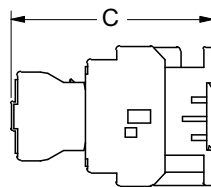

FOUR POLE
TOP MOUNTED
AUXILIARY

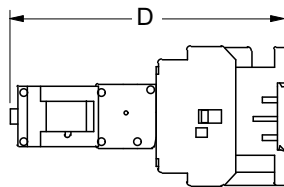

ON-POSITION
LATCH

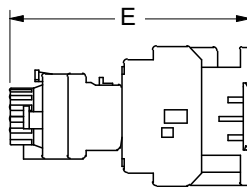

PNEUMATIC
TIMER

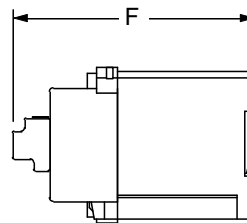

MECH INTERLOCK D.C.
OPERATED

Type		A	B	C	D	E	F
N	IN	2.20	3.96	4.21	5.71	5.00	—
	MM	56	100.5	107	145	127	—
NE	IN	2.20	3.96	4.21	5.71	5.00	—
	MM	56	100.5	107	145	127	—