

## Circuit diagrams Arc Guard System application

### Arc Guard System with current measuring in five incoming feeders

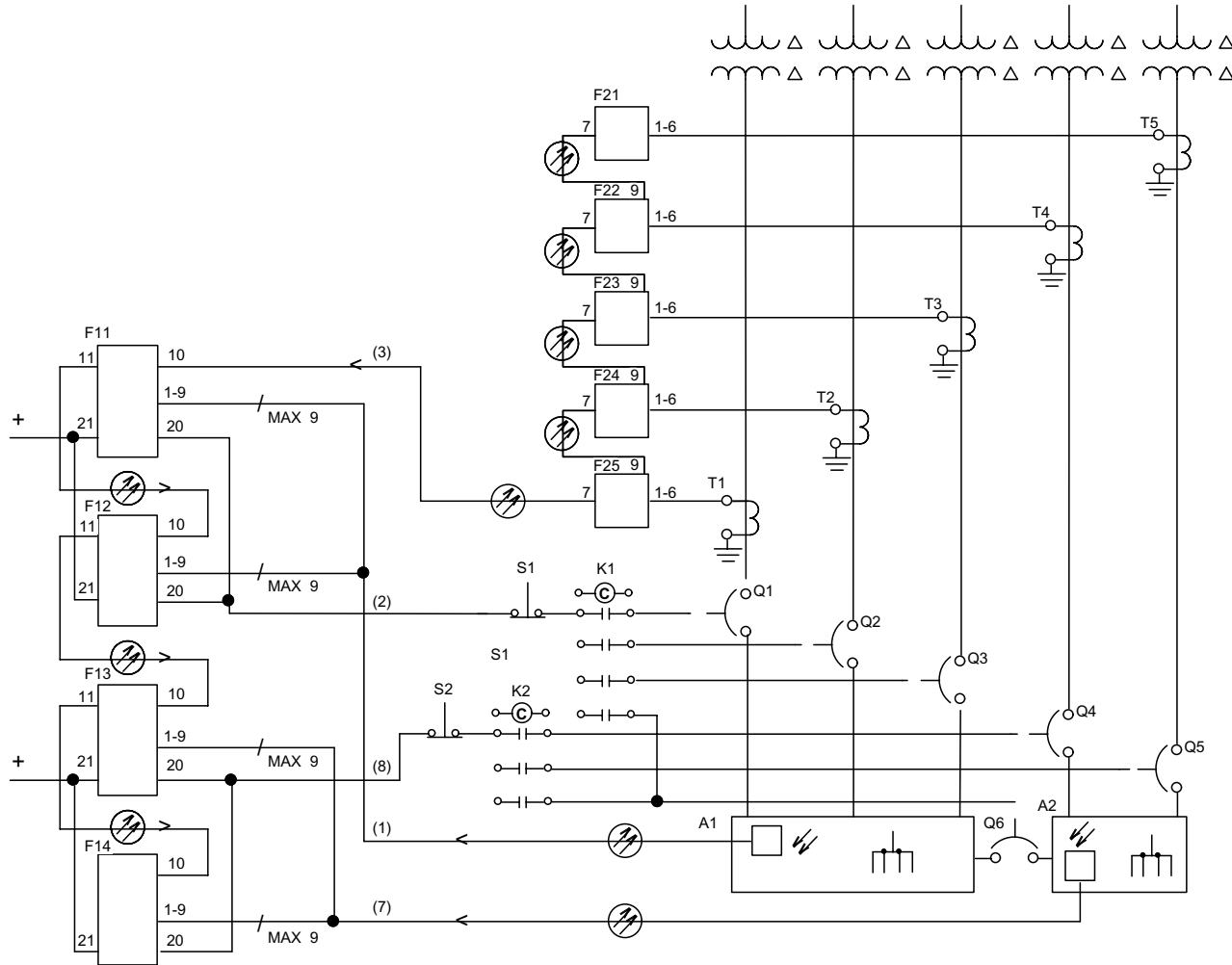

A1, A2 Switchgear or similar  
 F11...F14 Arc monitor  
 F21...F25 Current sensing unit  
 K1, K2 Fast tripping relay  
 T1...T5 Current transformers  
 Q1...Q5 Circuit breaker

Q6 Bus coupler  
 (1), (7) Detector cables (optical fiber cable)  
 (2), (8) Trip circuit for circuit breaker  
 (electric cable, separately powered)  
 (3) Current signal to Arc monitor  
 (optical fiber cable)