

## Circuit diagrams

### Single-Phase ①②

### PSS03 – PSS12

6

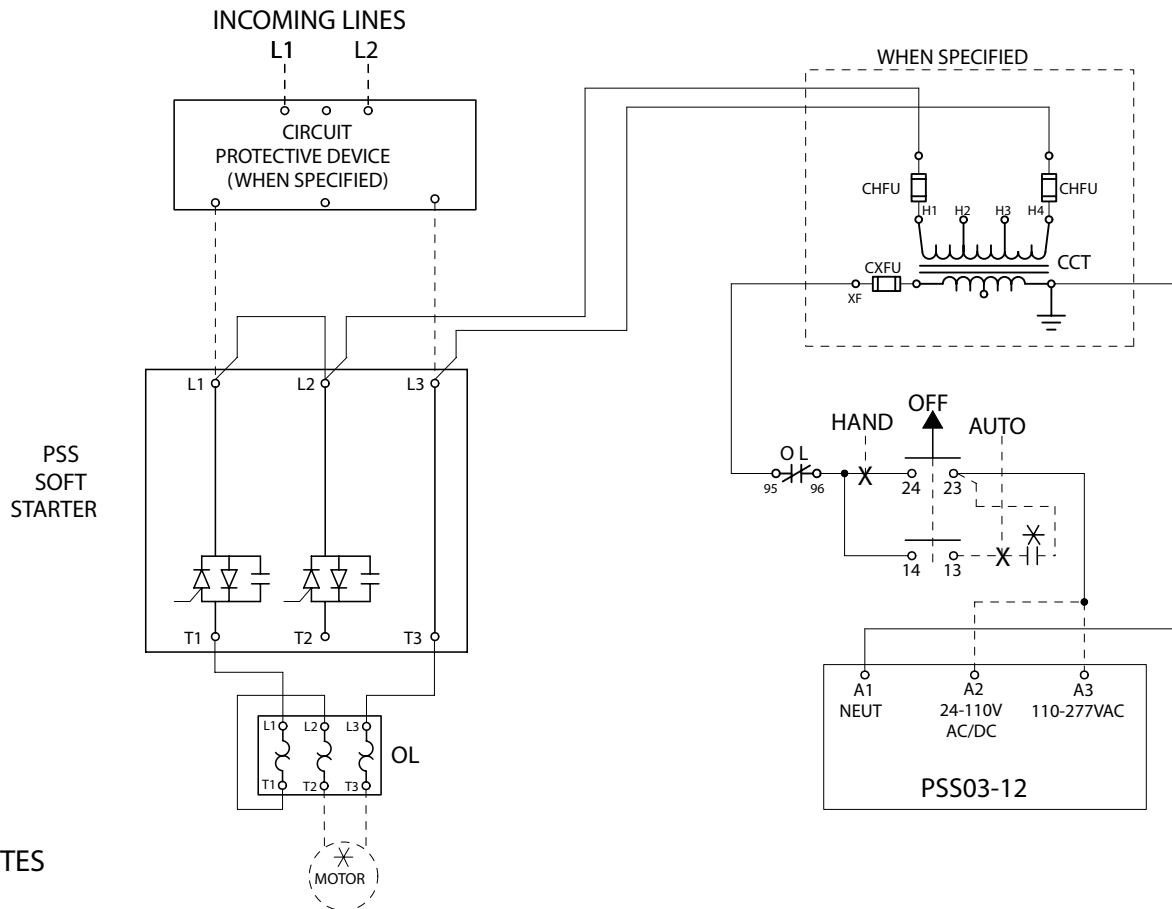

#### NOTES

1. ALL CONTROL WIRING TO BE 18GA. COLOR OF CONTROL WIRE SHALL BE PER VOLTAGE OF CONTACTOR COILS:  
RED - ALL AC VOLTAGES  
WHITE MAY BE USED ON THE GROUNDED SIDE OF THE AC CIRCUIT IF SPECIFIED.  
BLUE - ALL DC VOLTAGES
2. ALL DEVICES ARE SHOWN DE-ENERGIZED.
3. DO NOT USE SELECTOR SWITCHES WITH AUTO-RESET OVERLOAD RELAYS.

LEGEND	
CCT	CONTROL CIRCUIT TRANSFORMER
CHFU	CCT PRIMARY FUSE
CXFU	CCT SECONDARY FUSE
OL	OVERLOAD RELAY
○ <sub>13</sub>	CONN POINT ON DEVICE WITH NUMBER
X	REMOTE DEVICE
∅	CONN POINT AT TERMINAL BLOCK

① Softstarter voltage rating must be the same as the network voltage.  
② PSS25 cannot be used for single phase applications.