

Application examples C670x

Safety gate monitoring, two-channel, autostart category 4 / SIL 3 with voltage-operated e.l.c.b. and delayed disconnection, stop category 1

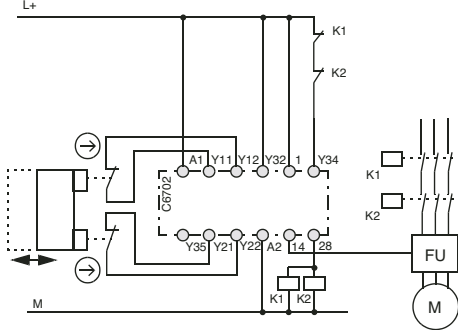

EMERGENCY STOP, single-channel, monitored start with additional ON button category 2 / SIL 1 with voltage-operated e.l.c.b. and delayed disconnection, stop category 1

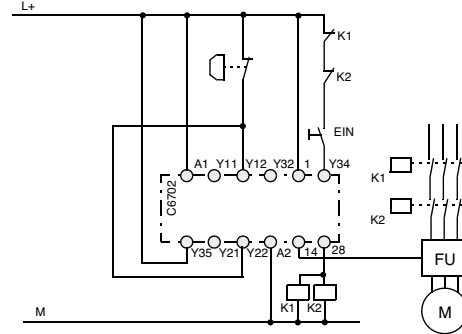

EMERGENCY STOP, two-channel, monitored start with additional ON button category 4 / SIL 3 with voltage-operated e.l.c.b. and delayed disconnection, stop category 1

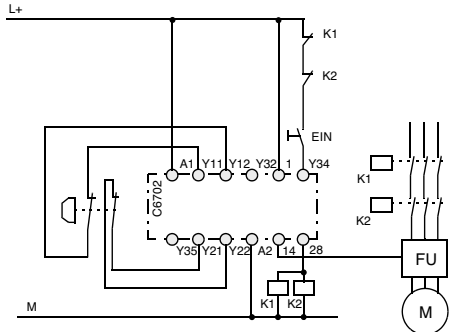

EMERGENCY STOP and safety gate monitoring, two channel with tumbler, monitored start category 4 / SIL 3

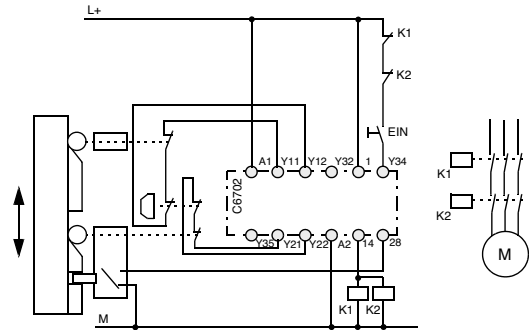

EMERGENCY STOP, two-channel, monitored start with additional ON button and safety gate monitoring, two-channel, autostart; category 4 / SIL 3

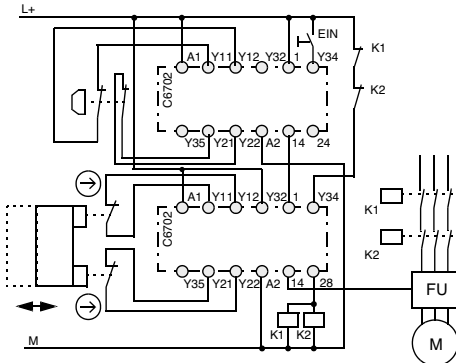

Light-array monitoring, two-channel, autostart category 4 SIL 3

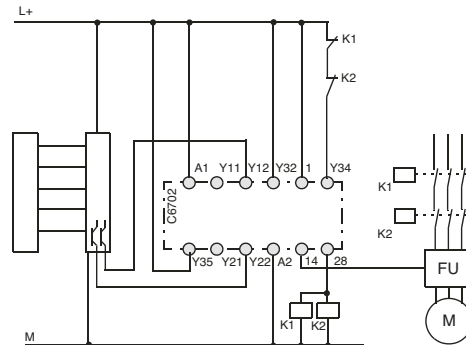

Safety mat, two-channel, autostart; category 3 SIL 2

