



Rotative axis limit switches

Description

Safety limit switches made of fibre-glass reinforced UL-V0 thermoplastic material, with rotative axis or flush mounting right angle lever, offer double insulation and a degree of protection IP65. They are equipped with 1 N.C. + 1 N.O. or 2 N.C. contact blocks with dependent action and positive opening operation of the "N.C." contact(s).

Applications

Easy to use, the limit switches with rotative axis or lever offer specific qualities:

- Visible operation.
- Capability for strong current switching (conventional thermal current 10 A).
- Opening of the "N.C." contact(s) for a very small rotation angle: 7°.
- Contact blocks with dependent action and positive opening operation of the "N.C." normally closed contact(s) (symbol \ominus).
- Electrically separated contacts (Zb shape).

- Precision on operating positions (consistency).
- Immunity to electromagnetic disturbances.

These specific features make the limit switches ideal for monitoring and protection of light industrial machines without inertia equipped with angular movement protectors (doors, hinged grids, rotative covers or cases, etc.). Detection by the rotative axis or by means of a lever.

- Opening of the mobile protector guarantees operator protection by immediately stopping the machine drive.
- These switches are suitable for conformity of the existing installed machine base, as they can be mounted on protection devices already installed.
- Associated with other standard limit switches and safety switching devices, they produce automatic control circuits meeting standard EN 954-1.
- They comply with the requirements of European Directives (Low Voltage, Machines and Electromagnetic Compatibility) and are conform to European and international standards.

9

Casing

- 30 mm wide with standardised dimensions corresponding to EN 50047

Casing fixing

- 2 x M4 screws in the top part

Blocks of 2 contacts

- Contact configuration: 1 N.O. + 1 N.C. or 2 N.C.
- Positive opening operation \ominus
- Contact dependent action
- Zb shape: the 2 contacts are electrically separated

Connecting terminals

- M3.5 screw with (+,-) pozidriv 2 head
- Screw heads with captive cable clamps
- Marking conform to IEC 60947-1, IEC 60947-5-1, EN 50005 and EN 50013 standards

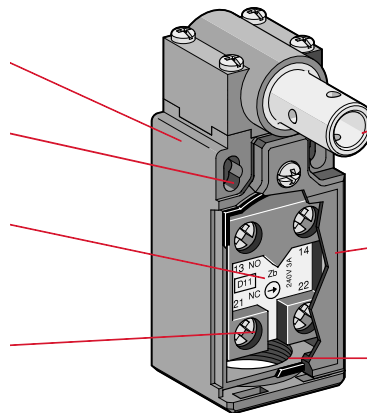

3 operating head options:

- Galvanised steel rotative axis
 - Stainless steel rotative axis
 - Galvanised steel flush mounting right angle lever
- Assembly by 4 x \varnothing 3 screws with (+,-) pozidriv 1 head

Cover

- Closure by 1 x \varnothing 3 screw with (+,-) pozidriv 1 head
- Gasket made in one part to prevent tightness breaks

Electrical connection in various options:

- 1 x Pg 13.5 cable gland for LS30P
- 1 x Pg 11 cable gland for LS31P
- 1 x 1/2" NPT adaptor delivered not mounted for LS35P

Catalog number explanation

Example : **LS 35 P 75 D11 S**

Limit Switch.....	LS					S	Safety device	
Casing width: 30 mm		3						
Cable inlet:							Contact types:	
1 cable inlet for Pg 13.5 cable gland.....						11	1 N.O. + 1 N.C. contacts	
1 cable inlet for Pg 11 cable gland.....						02	2 N.C. contacts	
1 x 1/2" NPT (adaptor) cable inlet.....								
Plastic casing.....			P				Snap action:	
							B	Zb Snap
Operating heads:							Dependent (slow) action:	
Galvanised steel rotative axis				75			L	Zb Slow / Simultaneous
Stainless steel rotative axis				76			D	Zb Non-overlapping late make
Galvanised steel flush mounting right angle lever				77			C	Zb Overlapping early make