

UL & CSA Technical data

A/AE9 – A/AE/AF110, AL9 – AL40

AC & DC operated

ABB contactor frame size		A/AE/AL 9	A/AE/AL 12	A/AE/AL 16	A/AE/AL 26	A/AE/AL 30	A/AE/AL 40	A/AE/AF 45	A/AE/AF 50	A/AE/AF 63	A/AE/AF 75	A/AE/AF 95	A/AE/AF 110
NEMA size		00	—	0	1	1P	—	—	2	—	3	—	—
Number of poles		3 OR 4	3	3 OR 4	3 OR 4	3	3	4	3 OR 4	3	3 OR 4	3	3
AC rating information													
NEMA cont. amp rating	thermal current	9	—	18	27	36	—	—	45	—	90	—	—
NEMA maximum H.P. ratings	1 phase												
	115 VAC	1/3	—	1	2	3	—	—	3	—	—	—	—
	230 VAC	1	—	2	3	5	—	—	7.5	—	—	—	—
NEMA maximum H.P. ratings	3 phase												
	200 VAC	1.5	—	3	7.5	—	—	—	10	—	25	—	—
	230 VAC	1.5	—	3	7.5	—	—	—	15	—	30	—	—
	460/575 VAC	2	—	5	10	—	—	—	25	—	50	—	—
U.L. general purpose current	40°C	21	25	30	40	50	60	65	80	90	105	125	140
Max. 3 Ph Switching motor loads	A	9	11	17	28	34	42	—	54	65	80	95	110
U.L. maximum H.P. ratings	1 phase												
	115 VAC	1/2	3/4	1.5	2	3	3	—	3	5	7.5	7.5	10
	230 VAC	2	2	3	5	7.5	7.5	—	7.5	10	15	20	25
U.L. maximum H.P. ratings	3 phase												
	200-208 VAC	2	3	5	7.5	10	10	—	15	20	25	30	30
	220-240 VAC	2	3	5	10	10	15	—	20	25	30	30	40
	440-480 VAC	5	7.5	10	20	25	30	—	40	50	60	60	75
	550-600 VAC	7.5	10	15	25	30	40	—	50	60	75	75	100
U.L. maximum H.P. ratings	VDC	1	1.5	2	3	3	5	—	7.5	10	10	—	—
	240 VDC	2	3	3	5	7.5	10	—	15	20	25	—	—
	Lighting — ballast and incandescent	600VAC	15	15	20 ①	35	50	60	65	65	85	105	120
Resistive heating applications	600VAC	15	15	20	35	50	60	65	65	85	105	—	—
CSA Elevator ratings													
220 – 240VAC	3 phase	—	—	5	—	—	10	—	15	—	20	20	—
440 – 480VAC	3 phase	—	—	10	—	—	20	—	30	—	30	40	—
550 – 600VAC	3 phase	—	—	10	—	—	20	—	30	—	40	50	—
230VAC	1 phase	—	—	2	—	—	5	—	7.5	—	10	10	—
Auxiliary contacts													
NEMA rating	AC	A600	A600	A600	A600	A600	A600	—	A600	A600	A600	A600	A600
AC rated voltage	VAC	600	600	600	600	600	600	—	600	600	600	600	600
AC thermal rated current	A	10	10	10	10	10	10	—	10	10	10	10	10
AC maximum volt-ampere making	VA	7200	7200	7200	7200	7200	7200	—	7200	7200	7200	7200	7200
AC maximum volt-ampere breaking	VA	720	720	720	720	720	720	—	720	720	720	720	720
NEMA rating	DC	P600	P600	P600	P600	P600	P600	—	P600	P600	P600	P600	P600
DC rated voltage	VDC	600	600	600	600	600	600	—	600	600	600	600	600
DC thermal rated current	A	5	5	5	5	5	5	—	5	5	5	5	5
DC Maximum make-break	A	0.2	0.2	0.2	0.2	0.2	0.2	—	0.2	0.2	0.2	0.2	0.2
Approximate weight													
Contactor	lbs.	0.7	0.7	0.7	1.01	1.2	2.25	2.25	2.25	2.25	2.25	3.5	5
Starter	lbs.	1.04	1.04	1.04	1.35	1.54	3	3	3	3	3	6	7
Terminal wire range													
Number of wires per phase	AWG	18-10	18-10	18-10	12-8	8-4	8-4	8-1	8-1	8-1	8-1	6-2/0	6-2/0
		2	2	2	2	2	2	1	1	1	1	1	1
Maximum short circuit ratings													
MCCB,MCP, Amps/kA	480VAC	50/35	50/35	50/35	100/35	150/65	150/65	—	150/85	250/85	250/85	250/85	250/85
MCCB,MCP, Amps/kA	600VAC	10/35	10/35	10/35	100/35	150/25	150/25	—	—	—	—	250/35	250/35
Fuse,Amps — type/kA	600VAC	30J/200	30J/200	30J/200	60J/200	60J/200	100J/200	—	100J/200	200J/200	200J/200	200J/200	200J/200

Mounting positions

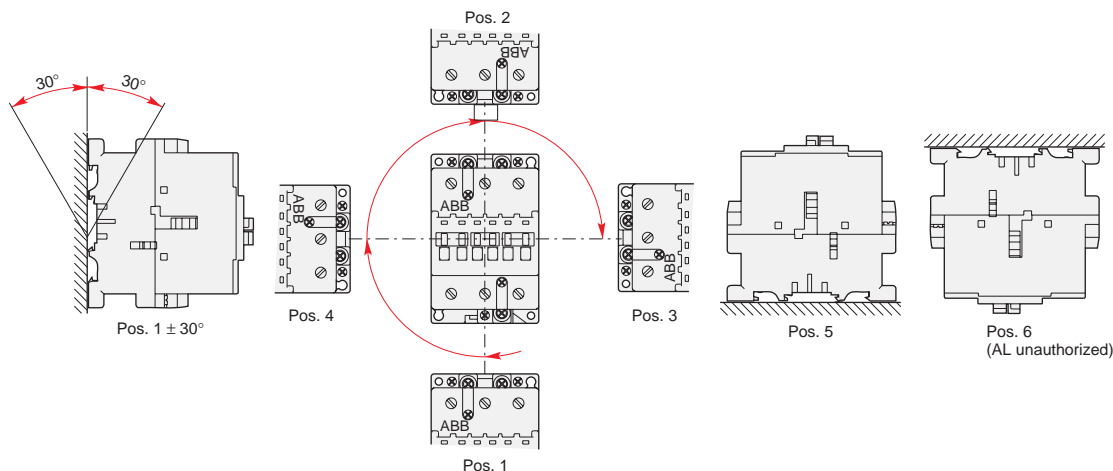

① 30A Ballast

UL & CSA Technical data

A/AF145 – AF750

AC & DC operated

Across the line
contactors

1

ABB contactor frame size		A/AF 145	A/AF 185	A/AF 210	A/AF 260	A/AF 300	AF 400	AF 460	AF 580	AF 750
NEMA size		4	—	—	5	—	—	6	—	7
Number of poles		3	3	3	3	3	3	3	3	3
AC rating information										
NEMA maximum H.P. ratings	3 phase									
200	VAC	40	—	—	75	—	—	150	—	—
230	VAC	50	—	—	100	—	—	200	—	300
460/575	V	100	—	—	200	—	—	400	—	600
U.L. general purpose current	40°C	230	250	300	350	400	550	650	750	900
Max. 3 Ph switching motor loads	Amps	130	156	192	248	302	414	480	590	720
U.L. maximum H.P. ratings	1 phase									
115	VAC	10	15	—	—	—	—	—	—	—
230	VAC	25	30	40	50	—	—	—	—	—
U.L. maximum H.P. ratings	3 phase									
200—208	VAC	40	50	60	75	100	125	150	200	250
220—240	VAC	50	60	75	100	100	150	200	250	300
440—480	VAC	100	125	150	200	250	350	400	500	600
550—600	VAC	125	150	200	250	300	400	500	600	700
Lighting – ballast and incandescent	600VAC	200	—	300	—	400	—	—	—	—
CSA Elevator ratings										
220 – 240VAC	3 phase			40	50	60	—	—	—	—
240 – 480VAC	3 phase	Consult factory	Consult factory	75	100	125	—	—	—	—
550 - 600VAC	3 phase	factory	factory	100	125	150	—	—	—	—
230VAC	1 phase			—	—	—	—	—	—	—
Auxiliary contacts										
NEMA rating	AC	A600	A600	A600	A600	A600	A600	A600	A600	A600
AC rated voltage	VAC	600	600	600	600	600	600	600	600	600
AC thermal rated current	A	10	10	10	10	10	10	10	10	10
AC maximum volt—ampere making	VA	7200	7200	7200	7200	7200	7200	7200	7200	7200
AC maximum volt—ampere breaking	VA	720	720	720	720	720	720	720	720	720
NEMA rating	DC	P600	P600	P600	P600	P600	P600	P600	P600	P600
DC rated voltage	VDC	600	600	600	600	600	600	600	600	600
DC thermal rated current	A	5	5	5	5	5	5	5	5	5
DC Maximum make—break	A	0.2	0.2	0.2	0.2	0.2	0.2	0.2	0.2	0.2
Approximate weight										
Contactor	lbs.	7.1	7.1	13	13	13	26	26	33	33
Starter	lbs.	9.11	9.11	17.67	17.67	17.67	35	35	45	45
Terminal wire range										
Number of wires per phase	AWG	6-250MCM 1	6-250MCM 1	4-400MCM 1	4-400MCM 1	4-500MCM 2	250-500MCM 2	250-500MCM 2	2/0-500MCM 2	2/0-500MCM 3
Maximum short circuit ratings										
MCCB,MCP,amps/kA	480VAC	400/85	400/85	800/85	800/85	800/85	800/80	800/80	1200/42	1200/42
MCCB,MCP,amps/kA	600VAC	400/35	400/35	800/35	800/35	800/35	800/42	800/42	—	—
Fuse, amps—Type/kA	600VAC	400J/200	400J/200	600J/200	600J/200	600J/200	1000L/80	1000L/80	1200L/80	1200L/80

UL & CSA Technical data

AF1350 – AF1650

AC & DC operated

ABB contactor frame size		AF 1350	AF 1650
NEMA size		—	8
Number of poles		3	3
AC rating information			
NEMA maximum H.P. ratings	3 phase		
200	VAC	—	—
230	VAC	—	450
460/575	V	—	900
U.L. general purpose current			
	40°C	1350	1650
Max. 3 Ph switching motor loads	Amps	960	1080
U.L. maximum H.P. ratings			
1 phase			
115	VAC	—	—
230	VAC	—	—
3 phase			
U.L. maximum H.P. ratings			
200—208	VAC	—	—
220—240	VAC	400	450
440—480	VAC	800	900
550—600	VAC	900	1000
Auxiliary contacts			
NEMA rating	AC	A600	A600
AC rated voltage	VAC	600	600
AC thermal rated current	A	10	10
AC maximum volt—ampere making	VA	7200	7200
AC maximum volt—ampere breaking	VA	720	720
NEMA rating	DC	P600	P600
DC rated voltage	VDC	600	600
DC thermal rated current	A	5	5
DC Maximum make—break	A	0.2	0.2
Approximate weight			
Contactor	lbs.	75	75
Starter	lbs.	—	—
Terminal wire range			
	AWG	1/0-750 MCM	1/0-750 MCM
Number of wires per phase		4	6
Maximum short circuit ratings			
MCCB,MCP,amps/kA	480VAC	2000/42	2000/42
MCCB,MCP,amps/kA	600VAC	—	—
Fuse, amps—Type/kA	600VAC	1600L/82	2000L/82

UL/CSA & IEC Technical data

A/AE9 – A/AE/AF/TAE110

Across the line
contactors

1

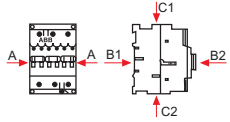
Contactor types: A..., AE... AF..., TAE...	9	12	16	26	30	40	45	50	63	75	95	110																		
	-	-	-	-	-	-	45	50	63	75	95	110																		
Rated insulation voltage U_i according to IEC 60947-4-1							1000																							
according to UL/CSA							600																							
Rated impulse withstand voltage U_{imp}							8																							
Standards	Devices complying with international standards IEC 60947-1 / 60947-4-1 and European standards EN 60947-1 / 60947-4-1																													
Air temperature close to contactor – fitted with thermal O/L relay	°C	see "Conditions for use" page 1.50, for control voltage limits and authorized mounting positions																												
– without thermal O/L relay	°C	-25 to +55																												
– for storage	°C	-40 to +70 (55 max. for TAE... contactors)										-40 to +70																		
		-60 to +80																												
Climatic withstand 30		acc. to IEC 60068-2-30 and 60068-2-11 - UTE C 63-100 specification II										acc. to IEC 68-2-																		
Operating altitude	m	≤ 3000																												
Shock withstand acc. IEC 60068-2-27 and EN 60068-2-27 Mounting position 1 (see page 1.50)		<p>1/2 sinusoidal shock for 11 ms: no change in contact position</p> <table border="1"> <thead> <tr> <th>Shock direction</th> <th>Making position</th> <th>Breaking position</th> </tr> </thead> <tbody> <tr> <td>A</td> <td>20 g</td> <td>20 g</td> </tr> <tr> <td>B1</td> <td>10 g</td> <td>5 g ①</td> </tr> <tr> <td>B2</td> <td>15 g ②</td> <td>15 g ②</td> </tr> <tr> <td>C1</td> <td>20 g</td> <td>20 g</td> </tr> <tr> <td>C2</td> <td>20 g</td> <td>20 g</td> </tr> </tbody> </table>											Shock direction	Making position	Breaking position	A	20 g	20 g	B1	10 g	5 g ①	B2	15 g ②	15 g ②	C1	20 g	20 g	C2	20 g	20 g
Shock direction	Making position	Breaking position																												
A	20 g	20 g																												
B1	10 g	5 g ①																												
B2	15 g ②	15 g ②																												
C1	20 g	20 g																												
C2	20 g	20 g																												
												Not valid for DIN-rail mounting																		

① 3 g for AF 45-22, AE 45-22, AF 75-22 and AE 75-22.

② 10 g for AF 45-22, AE 45-22, AF 75-22 and AE 75-22.

UL/CSA & IEC Technical data

A/AF145 – AF1650

A/AF145 – AF750

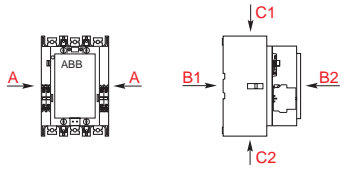
Contactor types:	A...	145	185	210	260	300	-	-	-	-	
	AF...	145	185	210	260	300	400	460	580	750	
Rated insulation voltage U_i according to IEC 60947-4-1 according to UL/CSA	V	1000 V600									
Rated impulse withstand voltage U_{imp} . Standards	kV	8 Devices complying with international standards IEC 60947-1 / 60947-4-1 and European standards EN 60947-1 / 60947-4-1									
Air temperature close to contactor – fitted with thermal O/L relay	°C	see "Conditions for use" page 1.51 , for control voltage limits and authorized mounting positions									
– without thermal O/L relay	°C	-25 to +55									
– for storage	°C	-40 to +70									
Climatic withstand		acc. to IEC 60068-2-30									
Operating altitude	m	≤ 3000									
Shock withstand acc. IEC 60068-2-27 and EN 60068-2-27 Mounting position 1 (see page 1.51)		1/2 sinusoidal shock for 30 ms: no change in contact position 5 g in all directions (A, B1, B2, C1, C2)									
											

AF1350 – AF1650

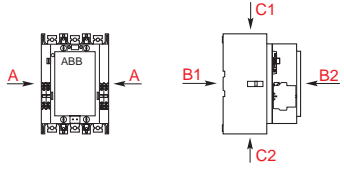
Contactor types:	AF...	1350	1650
Rated insulation voltage U_i according to IEC 60947-4-1 according to UL/CSA	V	1000 600	
Rated impulse withstand voltage U_{imp} . Standards	kV	8 Devices complying with international standards IEC 60947-1 / 60947-4-1 and European standards EN 60947-1 / 60947-4-1	
Air temperature close to contactor – fitted with thermal O/L relay		see "Conditions for use" page 1.51 , for control voltage limits and authorized mounting positions	
– without thermal O/L relay		°C-25 to +55	
– for storage		°C-40 to +70	
Climatic withstand		acc. to IEC 60068-2-30	
Operating altitude	m	≤ 3000	
Shock withstand acc. IEC 60068-2-27 and EN 60068-2-27 Mounting position 1 (See page 1.51)		1/2 sinusoidal shock for 30 ms: no change in contact position 5 g in all directions (A, B1, B2, C1, C2)	
			

IEC Technical data

DC circuit switching

A/AE9 – GAE75

General

The arc switching on d.c. is more difficult than on a.c.

- For selecting a contactor it is essential to determine the current, the voltage and the L/R time constant of the controlled load.
- For information, typical time constant values are quoted hereafter: non inductive loads such as resistance furnaces ($L/R \geq 1$ ms), inductive loads such as shunt motors ($L/R \geq 2$ ms) or series motors ($L/R \geq 7.5$ ms).
- The addition of a resistor in parallel with an inductive winding helps in the elimination of the arcs.
- All the poles required for breaking must be connected in series between the load and the source polarity not linked to earth (or chassis).

a.c. operated contactors		A9	A12	A16	A26	A30	A40	A45	A50	A63	A75	GA75	
a.c. / d.c. operated (electronic coil interface)		-	-	-	-	-	-	AF45	AF50	AF63	AF75	-	
d.c. operated contactors		AE9	AE12	AE16	AE26	AE30	AE40	AE45	AE50	AE63	AE75	GAE75	
Utilization category DC-1, $L/R \leq 1$ ms													
	≤ 72 V	A	25	27	30	45	55	60	70	100	110	120	120
	110 V	A	10	15	20	-	-	-	-	-	-	-	120
	220 V	A	-	-	-	-	-	-	-	-	-	-	120
	440 V	A	-	-	-	-	-	-	-	-	-	-	100
	600 V	A	-	-	-	-	-	-	-	-	-	-	75
	≤ 72 V	A	25	27	30	45	55	60	70	100	110	120	-
	110 V	A	25	27	30	45	55	60	70	100	110	120	-
	220 V	A	10	15	20	-	-	-	-	-	-	-	-
	≤ 72 V	A	25	27	30	45	55	60	70	100	110	120	-
	110 V	A	25	27	30	45	55	60	70	100	110	120	-
	220 V	A	25	27	30	45	55	60	70	100	110	120	-
	≤ 72 V	A	25	27	30	45	-	-	70	100	-	120	-
	110 V	A	25	27	30	45	-	-	70	100	-	120	-
	220 V	A	25	27	30	45	-	-	70	100	-	120	-
	440 V	A	10	15	20	-	-	-	-	-	-	-	-
Utilization category DC-3, $L/R \leq 2$ ms													
	≤ 72 V	A	25	27	30	45	55	60	70	100	110	120	120
	110 V	A	6	7	8	-	-	-	-	-	-	-	120
	220 V	A	-	-	-	-	-	-	-	-	-	-	100
	440 V	A	-	-	-	-	-	-	-	-	-	-	85
	≤ 72 V	A	25	27	30	45	55	60	70	100	110	120	-
	110 V	A	25	27	30	45	55	60	70	100	110	120	-
	220 V	A	6	7	8	-	-	-	-	-	-	-	-
	≤ 72 V	A	25	27	30	45	55	60	70	100	110	120	-
	110 V	A	25	27	30	45	55	60	70	100	110	120	-
	220 V	A	25	27	30	45	55	60	70	100	110	120	-
	≤ 72 V	A	25	27	30	45	-	-	70	100	-	120	-
	110 V	A	25	27	30	45	-	-	70	100	-	120	-
	220 V	A	25	27	30	45	-	-	70	100	-	120	-
	440 V	A	6	7	8	-	-	-	-	-	-	-	-
Utilization category DC-5, $L/R \leq 7.5$ ms													
	≤ 72 V	A	9	12	16	25	30	40	50	50	63	75	85
	110 V	A	4	4	4	-	-	-	-	-	-	-	85
	220 V	A	-	-	-	-	-	-	-	-	-	-	85
	440 V	A	-	-	-	-	-	-	-	-	-	-	35
	≤ 72 V	A	25	27	30	45	55	60	70	100	110	120	-
	110 V	A	10	15	20	30	45	50	70	80	90	100	-
	220 V	A	4	4	4	-	-	-	-	-	-	-	-
	≤ 72 V	A	25	27	30	45	55	60	70	100	110	120	-
	110 V	A	25	27	30	45	55	60	70	100	110	120	-
	220 V	A	9	12	16	25	30	40	50	50	63	75	-
	≤ 72 V	A	25	27	30	45	-	-	70	100	-	120	-
	110 V	A	25	27	30	45	-	-	70	100	-	120	-
	220 V	A	10	15	20	30	-	-	70	70	-	100	-
	440 V	A	4	4	4	-	-	-	-	-	-	-	-

IEC Technical data









DC circuit switching

A/AF/AE95 – AF750

Technical Data

- The tables indicate for the standard contactors the I_e max. operating currents depending on: the utilization category (i.e. L/R) DC-1, DC-3, DC-5 as defined in the IEC 60947-4-1 publication, the operating voltage U_e and the pole coupling details. See page 1.81.
Ampere values quoted in the tables below are valid for a $-25 \dots +70$ °C temperature close to the contactors, as long as the AC-1 Ampere values (see pages 1.45 - 146) for the corresponding ambient temperature are not exceeded.
- Max. switching frequency: 300 ops/h.
- For switching higher d.c. ratings, we recommend the use of bar mounted contactors, R series (63 ... 2000 A).

The selection table for AE 50 ... AE 110 contactors can be used for the TAE 50 ... TAE 110 types.

a.c. operated contactors a.c. / d.c. operated (electronic coil interface) d.c. operated contactors			A95 AF95 AE95	A110 AF110 AE110	A145 AF145 -	A185 AF185 -	A210 AF210 -	A260 AF260 -	A300 AF300 -	- AF400 -	- AF460 -	- AF580 -	- AF750 -
Utilization category DC-1, L/R ≤ 1 ms													
	≤ 110 V	A	-	-	-	-	-	-	-	600	700	800	1050
	≤ 110 V	A	145	160	250	275	350	400	450	600	700	800	1050
	220 V	A	-	-	-	-	-	-	-	600	700	800	1050
	≤ 110 V	A	145	160	250	275	350	400	450	600	700	800	1050
	220 V	A	145	160	250	275	350	400	450	600	700	800	1050
	440 V	A	-	-	-	-	-	-	-	600	700	800	1050
	600 V	A	-	-	-	-	-	-	-	600	700	800	1050
Utilization category DC-3, L/R ≤ 2.5 ms													
	≤ 110 V	A	-	-	-	-	-	-	-	600	700	800	1050
	≤ 110 V	A	145	160	250	275	350	400	450	600	700	800	1050
	220 V	A	-	-	-	-	-	-	-	600	700	800	1050
	≤ 110 V	A	145	160	250	275	350	400	450	600	700	800	1050
	220 V	A	145	160	250	275	350	400	450	600	700	800	1050
	440 V	A	-	-	-	-	-	-	-	600	700	800	1050
	600 V	A	-	-	-	-	-	-	-	600	700	800	1050
Utilization category DC-5, L/R ≤ 15 ms													
	≤ 110 V	A	-	-	-	-	-	-	-	600	700	800	1050
	≤ 110 V	A	145	160	250	275	350	400	450	600	700	800	1050
	220 V	A	-	-	-	-	-	-	-	600	700	800	1050
	≤ 110 V	A	145	160	250	275	350	400	450	600	700	800	1050
	220 V	A	145	160	250	275	350	400	450	600	700	800	1050
	440 V	A	-	-	-	-	-	-	-	600	700	800	1050
	600 V	A	-	-	-	-	-	-	-	600	700	800	1050

IEC Technical data

DC circuit switching

AL9 — AL40

General

The arc switching on d.c. is more difficult than on a.c.

- For selecting a contactor it is essential to determine the current, the voltage and the L/R time constant of the controlled load.
- For information, typical time constant values are quoted hereafter: non inductive loads such as resistance furnaces ($L/R \geq 1$ ms), inductive loads such as shunt motors ($L/R \geq 2$ ms) or series motors ($L/R \geq 7.5$ ms).
- The addition of a resistor in parallel with an inductive winding helps in the elimination of the arcs.
- All the poles required for breaking must be connected in series between the load and the source polarity not linked to earth (or chassis).

A.C. operated contactors		AL9	AL12	AL16	AL26	AL30	AL40	
Utilization category DC-1, $L/R \leq 1$ ms								
	≤ 72 V	A	25	27	30	45	55	60
	110 V	A	10	15	20	-	-	-
	220 V	A	-	-	-	-	-	-
	440 V	A	-	-	-	-	-	-
	600 V	A	-	-	-	-	-	-
	≤ 72 V	A	25	27	30	45	55	60
	110 V	A	25	27	30	45	55	60
	220 V	A	10	15	20	-	-	-
	≤ 72 V	A	25	27	30	45	55	60
	110 V	A	25	27	30	45	55	60
	220 V	A	25	27	30	45	55	60
	≤ 72 V	A	25	27	30	45	-	-
	110 V	A	25	27	30	45	-	-
	220 V	A	25	27	30	45	-	-
	440 V	A	10	15	20	-	-	-
Utilization category DC-3, $L/R \leq 2$ ms								
	≤ 72 V	A	25	27	30	45	55	60
	110 V	A	6	7	8	-	-	-
	220 V	A	-	-	-	-	-	-
	440 V	A	-	-	-	-	-	-
	≤ 72 V	A	25	27	30	45	55	60
	110 V	A	25	27	30	45	55	60
	220 V	A	6	7	8	-	-	-
	≤ 72 V	A	25	27	30	45	55	60
	110 V	A	25	27	30	45	55	60
	220 V	A	25	27	30	45	55	60
	≤ 72 V	A	25	27	30	45	-	-
	110 V	A	25	27	30	45	-	-
	220 V	A	25	27	30	45	-	-
	440 V	A	6	7	8	-	-	-
Utilization category DC-5, $L/R \leq 7.5$ ms								
	≤ 72 V	A	9	12	16	25	30	40
	110 V	A	4	4	4	-	-	-
	220 V	A	-	-	-	-	-	-
	440 V	A	-	-	-	-	-	-
	≤ 72 V	A	25	27	30	45	55	60
	110 V	A	10	15	20	30	45	50
	220 V	A	4	4	4	-	-	-
	≤ 72 V	A	25	27	30	45	55	60
	110 V	A	25	27	30	45	55	60
	220 V	A	9	12	16	25	30	40
	≤ 72 V	A	25	27	30	45	-	-
	110 V	A	25	27	30	45	-	-
	220 V	A	10	15	20	30	-	-
	440 V	A	4	4	4	-	-	-

IEC Technical data

DC circuit switching

EK110 — EK1000

General



















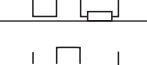



The arc switching on d.c. is more difficult than on a.c.

- For selecting a contactor it is essential to determine the current, the voltage and the L/R time constant of the controlled load.
- For information, typical time constant values are quoted hereafter: non inductive loads such as resistance furnaces ($L/R \leq 1$ ms), inductive loads such as shunt motors ($L/R \leq 2$ ms) or series motors ($L/R \leq 7.5$ ms).
- The addition of a resistor in parallel with an inductive winding helps in the elimination of the arcs.
- All the poles required for breaking must be connected in series between the load and the source polarity not linked to earth (or chassis).

Technical Data

- The tables indicate for the standard contactors the I_b max. operating currents depending on: the utilization category (i.e. L/R) DC-1, DC-3, DC-5 as defined in the IEC 60947-4-1 publication (see page 1.75 for more details), the operating voltage U_b and the pole coupling details. Ampere values quoted in the tables below are valid for a $-25 \dots +70$ °C temperature close to the contactors, as long as the AC-1 Ampere values (see page 1.61) for the corresponding ambient temperature are not exceeded.
- Max. switching frequency: 300 ops/h.
- For switching higher d.c. ratings, we recommend the use of bar mounted contactors, R series (63 ... 2000 A).

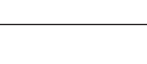
Selection Table

a.c. / d.c. operated contactors			EK110	EK150	EK175	EK210	EK370	EK550	EK1000
Utilization category DC-1, $L/R \leq 1$ ms									
	≤ 72 V	A	120	145	210	210	370	550	-
	110 V	A	120	145	210	210	370	550	-
	≤ 72 V	A	200	200	300	300	550	800	-
	110 V	A	200	200	300	300	550	800	-
	220 V	A	200	200	300	300	550	800	-
	≤ 72 V	A	200	200	300	300	550	800	-
	110 V	A	200	200	300	300	550	800	-
	220 V	A	200	200	300	300	550	800	-
	440 V	A	-	-	210	210	450	650	-
	600 V	A	-	-	-	-	450	650	-
	≤ 72 V	A	200	200	300	300	550	800	-
	110 V	A	200	200	300	300	550	800	-
	220 V	A	200	200	300	300	550	800	-
	440 V	A	200	200	260	300	450	650	-
	600 V	A	-	-	260	300	450	650	-
	≤ 72 V	A	200	200	300	300	550	800	-
	110 V	A	200	200	300	300	550	800	-
	220 V	A	200	200	300	300	550	800	-
	440 V	A	200	200	260	300	450	650	-
	600 V	A	-	-	260	300	450	650	-
Utilization category DC-3, $L/R \leq 2$ ms									
	≤ 72 V	A	120	145	210	210	370	550	-
	≤ 72 V	A	135	145	210	210	450	650	-
	110 V	A	135	135	210	210	450	650	-
	220 V	A	135	135	210	210	450	650	-
	≤ 72 V	A	135	145	210	210	450	650	-
	110 V	A	135	135	210	210	450	650	-
	220 V	A	135	135	210	210	450	650	-
	440 V	A	-	-	210	210	450	650	-
	600 V	A	-	-	-	-	450	650	-
	≤ 72 V	A	135	145	210	210	450	650	-
	110 V	A	135	135	210	210	450	650	-
	220 V	A	135	135	210	210	450	650	-
	440 V	A	135	135	210	210	450	650	-
	600 V	A	-	-	170	210	450	650	-
Utilization category DC-5, $L/R \leq 7.5$ ms									
	≤ 72 V	A	135	145	210	210	450	650	-
	110 V	A	135	135	210	210	450	650	-
	220 V	A	135	135	210	210	450	650	-
	≤ 72 V	A	135	145	210	210	450	650	-
	110 V	A	135	135	210	210	450	650	-
	220 V	A	135	135	210	210	450	650	-
	440 V	A	-	-	210	210	450	650	-
	600 V	A	-	-	-	-	450	650	-
	≤ 72 V	A	135	145	210	210	450	650	-
	110 V	A	135	135	210	210	450	650	-
	220 V	A	135	135	210	210	450	650	-
	440 V	A	135	135	210	210	450	650	-
	600 V	A	-	-	170	210	450	650	-

IEC Technical data

A/AE9 — A/AE/AF/TAE110

Across the line
contactors

1

Main Pole - Utilization Characteristics

Contactor types:	A..., AE...	9	12	16	26	30	40	45	50	63	75	95	110	
	AF..., TAE...	-	-	-	-	-	-	45	50	63	75	95	110	
Rated operational voltage U_e max.	V	690						1000 (690 for AF... contactors)						
Rated frequency limits	Hz	25-400												
Conventional free-air thermal current I_{th} acc. to IEC 60947-4-1, open contactors $\varnothing \leq 40^\circ\text{C}$	A	26	28	30	45	65	65	100	100	125	125	145	160	
with conductor cross-sectional area mm^2	4	4	4	6	16	16	35	35	50	50	70	70		
Rated operational current I_e / AC-1 for air temperature close to contactor	A	25	27	30	45	55	60	70	100	115	125	145	160	
U_e max. 690 V	$\varnothing \leq 40^\circ\text{C}$	A	22	25	27	40	55	60	60	85	95	105	135	145
	$\varnothing \leq 55^\circ\text{C}$	A	18	20	23	32	39	42	50	70	80	85	115	130
	$\varnothing \leq 70^\circ\text{C}$ ③	A	2.5	4	4	6	10	16	25	35	50	50	50	70
with conductor cross-sectional area mm^2		2.5	4	4	6	10	16	25	35	50	50	50	70	
Utilization categorie AC-3														
for air temperature close to contactor $\leq 55^\circ\text{C}$														
Rated operational current I_e AC-3 ①														
3-phase motors	220-230-240 V	A	9	12	17	26	33	40	40	53	65	75	96	110
	380-400 V	A	9	12	17	26	32	37	37	50	65	75	96	110
	415 V	A	9	12	17	26	32	37	37	50	65	72	96	110
	440 V	A	9	12	16	26	32	37	37	45	65	70	93	100
	500 V	A	9	12	14	22	28	33	33	45	55	65	80	100
	690 V	A	7	9	10	17	21	25	25	35	43	46	65	82
	1000 V	A	-	-	-	-	-	-	-	23 ②	25 ②	28 ②	30 ②	30 ②
Rated operational power AC-3 ①														
1500 r.p.m. 50 Hz 1800 r.p.m. 60 Hz 3-phase motors	220-230-240 V	kW	2.2	3	4	6.5	9	11	11	15	18.5	22	25	30
	380-400 V	kW	4	5.5	7.5	11	15	18.5	18.5	22	30	37	45	55
	415 V	kW	4	5.5	9	11	15	18.5	18.5	25	37	40	55	59
	440 V	kW	4	5.5	9	15	18.5	22	22	25	37	40	55	59
	500 V	kW	5.5	7.5	9	15	18.5	22	22	30	37	45	55	59
	690 V	kW	5.5	7.5	9	15	18.5	22	22	30	37	40	55	75
	1000 V	kW	-	-	-	-	-	-	-	30 ②	33 ②	37 ②	40 ②	40 ②
Rated making capacity AC-3 according to IEC 60947-4-1														
10 x I_e AC-3														
Rated breaking capacity AC-3 according to IEC 60947-4-1														
8 x I_e AC-3														
Short-circuit protection for contactors without thermal O/L relay - Motor protection excluded														
$U_e \leq 500$ V a.c. - gG type fuse	A	25	32	32	50	63	80	100	125	160	160	200		
Rated short-time withstand current I_{cw} at 40°C ambient temp., in free air, from a cold state														
1 s	A	250	280	300	400	600	1000					1320	1320	
10 s	A	100	120	140	210	400	650					800	800	
30 s	A	60	70	80	110	225	370					500	500	
1 min	A	50	55	60	90	150	250					350	350	
15 min	A	26	28	30	45	65	110	110	135	135	160	160	175	
Maximum breaking capacity $\cos \varnothing = 0.45$ ($\cos \varnothing = 0.35$ for $I_e > 100$ A)														
at 440 V	A	250			420	820	900	1300				1160		
at 690 V	A	90			170	340	490	630				800		
Heat dissipation per pole														
I_e / AC-1	W	0.8	1	1.2	1.8	2.5	3	2.5	5	6.5	7	6.5	7.5	
I_e / AC-3	W	0.1	0.2	0.35	0.6	0.9	1.3	0.65	1.3	1.5	2	2.7	3.6	
Max. electrical switching frequency														
- for AC-1	cycles/h	600						600 (300 for AF..., AE... TAE...)					300	
- for AC-3	cycles/h	1200 (600 for AE...)						600 (300 for AF..., AE... TAE...)					300	
- for AC-2, AC-4	cycles/h	300						150					150	
Electrical durability														
see pages 1.70 - 1.73														
Mechanical durability														
- millions of operating cycles		10 (5 for AE... and TAE... contactors)												
- max. mechanical switching frequency	cycles/h	3600 (300 for AF... contactors)												



① For the corresponding hp/A values of 1500 r.p.m., 50Hz, 3-phase motors, see page 1.76.

② AF... contactors excluded

③ Unauthorized for TAE... contactors.

IEC Technical data
A/AF145 – AF750

Main Pole - Utilization Characteristics

Contactor types:	A...	145	185	210	260	300	-	-	-	-		
	AF...	145	185	210	260	300	400	460	580	750		
Rated operational voltage U_e max.	V	690										
Rated frequency limits	Hz	25 ... 400										
Conventional free-air thermal current I_{th} acc. to IEC 60947-4-1, open contactors $\varnothing \leq 40^\circ\text{C}$												
with conductor cross-sectional area ①	mm ²	250	275	350	400	500	600	700	800	1050		
		120	150	185	240	300 ③	2 x 185	2 x 240	2 x 240	2 x 80 x 5 ②		
Rated operational current I_e / AC-1 for air temperature close to contactor												
U_e max. 690 V	$\varnothing \leq 40^\circ\text{C}$ $\varnothing \leq 55^\circ\text{C}$ $\varnothing \leq 70^\circ\text{C}$	A	250	275	350	400	500	600	700	800	1050	
		A	230	250	300	350	400	500	600	700	800	
		A	180	180	240	290	325	400	480	580	720	
with conductor cross-sectional area	mm ²	120	150	185	240	300 ③	2 x 185	2 x 240	2 x 240	2 x 80 x 5 ②		
Utilization categorie AC-3 for air temperature close to contactor $\leq 55^\circ\text{C}$												
Rated operational current I_e AC-3												
3-phase motors 	220-230-240 V	A	145	185	210	260	305	400	460	580	750	
	380-400 V	A	145	185	210	260	305	400	460	580	750	
	415 V	A	145	185	210	260	300	400	460	580	750	
	440 V	A	145	185	210	240	280	400	460	580	750	
	500 V	A	145	170	210	240	280	400	460	580	750	
	690 V	A	120	170	210	220	280	350	400	500	650	
	1000 V	A	-	-	-	-	-	-	-	-	-	
Rated operational power AC-3												
1500 r.p.m. 50 Hz 1800 r.p.m. 60 Hz 3-phase motors 	220-230-240 V	kW	45	55	59	80	90	110	132	160	220	
	380-400 V	kW	75	90	110	140	160	200	250	315	400	
	415 V	kW	75	90	110	140	160	220	250	355	425	
	440 V	kW	75	90	110	140	160	220	250	355	450	
	500 V	kW	90	110	132	180	200	250	315	400	520	
	690 V	kW	110	132	160	200	250	315	355	500	600	
	1000 V	kW	-	-	-	-	-	-	-	-	-	
Rated making capacity AC-3 according to IEC 60947-4-1												
		10 x I_e AC-3										
Rated breaking capacity AC-3 according to IEC 60947-4-1												
		8 x I_e AC-3										
Short-circuit protection for contactors without thermal O/L relay - Motor protection excluded $U_e \leq 500$ V a.c. - gG type fuse												
	A	315	355	400	500	630	800	1000				
Rated short-time withstand current I_{cw} at 40°C ambient temp., in free air, from a cold state												
	1 s	A	1800	2000	2500	3500	4600	7000				
	10 s	A	1200	1500	1700	2400	4400	6400				
	30 s	A	800	1000	1200	1500	3100	4500				
	1 min	A	600	800	1000	1100	2500	3500				
	15 min	A	280	320	400	500	840	1300				
Maximum breaking capacity $\cos \varnothing = 0.45$ ($\cos \varnothing = 0.35$ for $I_e > 100$ A)												
	at 440 V	A	1500	2000	2300	2600	3000	4000	5000	6000	7500	
	at 690 V	A	1200	1600	2000	2400	2500	3500	4500	5000	7000	
Heat dissipation per pole												
	I_e / AC-1	W	13	16	18	25	32	30	42	32	50	
	I_e / AC-3	W	5	8	9	14	18	16	21	17	28	
Max. electrical switching frequency												
- for AC-1	cycles/h	300			300			300			300	
- for AC-3	cycles/h	300			300			300			300	
- for AC-2, AC-4	cycles/h	150			150			60			60	
Electrical durability												
		see pages 1.65 ... 1.69										
Mechanical durability												
- millions of operating cycles		5							3			
- max. mechanical switching frequency	cycles/h	3600 (300 for AF... contactors)					300					

① Conductors with preparation.



② Dimensions of the bars (in mm).

③ For currents above 450A, use terminal extension / enlargement pieces LX 300 / LW 300 see page 1.31).

IEC Technical data

AF1350 – AF1650

Main Pole - Utilization Characteristics

Contactor types: AF...		1350	1650
Rated operational voltage U_e max.	V	1000	1000
Rated frequency limits	Hz	25-400	25-400
Conventional free-air thermal current I_{th} acc. to IEC 60947-4-1, open contactors $\varnothing \leq 40^\circ\text{C}$	A	1350	1650
with conductor cross-sectional area ^①	mm ²	2/100x5	3/100x5
Rated operational current I_e / AC-1 for air temperature close to contactor			
U_e max. 690 V	$\varnothing \leq 40^\circ\text{C}$ A	1350	1650
	$\varnothing \leq 55^\circ\text{C}$ A	1150	1450
	$\varnothing \leq 70^\circ\text{C}$ A	1000	1270
with conductor cross-sectional area	mm ²	2 x 80 x 5 ^①	2 x 80 x 5 ^①
Utilization categorie AC-3 for air temperature close to contactor $\leq 55^\circ\text{C}$			
Rated operational current I_e AC-3			
	220-230-240 V A	860	1050
3-phase motors	380-400 V A	860	1050
	415 V A	860	1050
	440 V A	860	1050
	500 V A	—	—
	690 V A	—	—
	1000 V A	—	—
			
Rated operational power AC-3			
	220-230-240 V kW	257	315
	380-400 V kW	475	560
1500 r.p.m. 50 Hz	415 V kW	500	600
1800 r.p.m. 60 Hz	440 V kW	560	670
3-phase motors	500 V kW	—	—
	690 V kW	—	—
	1000 V kW	—	—
			
Rated making capacity AC-3 according to IEC 60947-4-1		10 x I_e , AC-3	
Rated breaking capacity AC-3 according to IEC 60947-4-1		8 x I_e , AC-3	
Short-circuit protection for contactors without thermal O/L relay - Motor protection excluded $U_e \leq 500$ V a.c. - gG type fuse	A	Product coordination with ABB circuit breaker Consult factory	
Rated short-time withstand current I_{cw} at 40°C ambient temp., in free air, from a cold state			
	1 s A	10,000	12,000
	10 s A	8000	10,000
	30 s A	6000	7500
	1 min A	4500	5500
	15 min A	1600	2200
Maximum breaking capacity $\cos \varnothing = 0.45$ ($\cos \varnothing = 0.35$ for $I_e > 100$ A)			
	at 440 V A	10,000	12,000
	at 690 V A	—	—
Max. electrical switching frequency			
– for AC-1	cycles/h	60	60
– for AC-3	cycles/h		
– for AC-2, AC-4	cycles/h		
Electrical durability		50,000	50,000
Mechanical durability			
– millions of operating cycles		500,000	500,000
– max. mechanical switching frequency	cycles/h	60	60

① Dimensions of the bars (in mm).

IEC Technical data

A/AF9 — AF110

Magnet System Characteristics for A... Contactors

Contactor types:	A...	9	12	16	26	30	40	45	50	63	75	95	110
Rated control circuit voltage U_c													
– at 50 Hz	V	20 ... 690											
– at 60 Hz	V	24 ... 600											
Coil operating limits according to IEC 60947-4-1		$\vartheta \leq 55^\circ\text{C}$						$\vartheta \leq 70^\circ\text{C}$					
		0.85 ... 1.1 x U_c											
Drop-out voltage in % of U_c		roughly 40 ... 65 %											
Coil consumption													
Average pull-in value	50 Hz VA	70			120			180				350	
	60 Hz VA	80			140			210				450	
	50/60 Hz ① VA/VA	74/70			125/120			190/180				410/365	
Average holding value	50 Hz VA/W	8/2			12/3			18/5.5				22/6.5	
	60 Hz VA/W	8/2			12/3			18/5.5				26/8	
	50/60 Hz ① VA/W	8/2			12/3			18/5.5				27/7.5	
Operating time													
between coil energization and:													
– N.O. contact closing	ms	10 ... 26			8 ... 21			8 ... 27				10 ... 25	
– N.C. contact opening	ms	7 ... 21			6 ... 18			7 ... 22				7 ... 22	
between coil de-energization and:													
– N.O. contact opening	ms	4 ... 11			4 ... 11			4 ... 11				7 ... 15	
– N.C. contact closing	ms	9 ... 16			7 ... 14			7 ... 14				10 ... 18	

Magnet System Characteristics for AF... Contactors

Contactor types:	AF...	-	-	-	-	-	-	45	50	63	75	95	110
Rated control circuit voltage U_c													
– at 50 Hz	V	48 ... 250											
– at 60 Hz	V	48 ... 250											
– d.c.	V	20 ... 250											
Coil operating limits according to IEC 60947-4-1		$\vartheta \leq 70^\circ\text{C}$											
		0.85 ... 1.1 x U_c											
Drop-out voltage in % of U_c		55 %											
Coil consumption													
Average pull-in value	50 Hz VA							210				350	
	60 Hz VA							210				350	
	d.c. W							190				400	
Average holding value	50 Hz VA/W							7/2.8				7/3.5	
	60 Hz VA/W							7/2.8				7/3.5	
	d.c. W							2.8				2	
Operating time													
between coil energization and:													
– N.O. contact closing	ms							30 ... 100				30 ... 80	
– N.C. contact opening	ms							27 ... 95				27 ... 77	
between coil de-energization and:													
– N.O. contact opening	ms							30 ... 110				55 ... 125	
– N.C. contact closing	ms							35 ... 115				60 ... 130	

① 50/60 Hz coils: voltage codes 8 0 to 8 8. see page 1.28.

IEC Technical data

A145 — AF750

Across the line
contactors

1

Magnet System Characteristics for A... Contactors

Contactor types:	A...	145	185	210	260	300	-	-	-	-
Rated control circuit voltage U_c										
- at 50 Hz	V	24 ... 690								
- at 60 Hz	V	24 ... 690								
Coil operating limits according to IEC 60947-4-1		$\vartheta \leq 70 \text{ }^\circ\text{C}$ 0.85 ... 1.1 x U_c								
Drop-out voltage in % of U_c		roughly 25 ... 65 %								
Coil consumption										
Average pull-in value	50 Hz	VA	550		1350					
	60 Hz	VA	600		1550					
	50/60 Hz ①	VA/VA	700/650		1700/1550					
Average holding value	50 Hz	VA/W	35/11		60/16					
	60 Hz	VA/W	40/12		65/19					
	50/60 Hz ①	VA/W	44/13		80/21					
Operating time										
between coil energization and:										
- N.O. contact closing	ms		13 ... 27		17 ... 35					
- N.C. contact opening	ms		8 ... 22		12 ... 30					
between coil de-energization and:										
- N.O. contact opening	ms		5 ... 10		7 ... 13					
- N.C. contact closing	ms		9 ... 13		10 ... 16					

Magnet System Characteristics for AF... Contactors

Contactor types:	AF...	145	185	210	260	300	400	460	580	750
Rated control circuit voltage U_c										
- at 50 Hz	V	48 ... 250								
- at 60 Hz	V	48 ... 250								
- d.c.	V	24 ... 250								
Coil operating limits according to IEC 60947-4-1		$\vartheta \leq 70 \text{ }^\circ\text{C}$ 0.85 ... 1.1 x U_c								
Drop-out voltage in % of U_c		55 %								
Coil consumption										
Average pull-in value	50 Hz	VA	430		470		890		850	
	60 Hz	VA	430		470		890		850	
	d.c.	W	500		520		990		950	
Average holding value	50 Hz	VA/W	12/3.5		10/2.5		12/4		12/4.5	
	60 Hz	VA/W	12/3.5		10/2.5		12/4		12/4.5	
	d.c.	W	2		2		4		4.5	
Operating time										
between coil energization and:										
- N.O. contact closing	ms		30 ... 115				50 ... 120			
- N.C. contact opening	ms		30 ... 115				50 ... 120			
between coil de-energization and:										
- N.O. contact opening	ms		25 ... 80				40 ... 70			
- N.C. contact closing	ms		25 ... 80				40 ... 70			

① 50/60 Hz coils: voltage codes 8 0 to 8 8. see page 1.28.

IEC Technical data

AF1350 — AF1650

Magnet System Characteristics for AF... Contactors

Contactor types:	AF...		1350	1650
Rated control circuit voltage U_c				
– at 50 Hz	V		100 - 250	
– at 60 Hz	V		100 - 250	
– d.c.	V		100 - 250	
Coil operating limits according to IEC 60947-4-1				
			$\vartheta \leq 70\text{ °C}$	
			0.85 ... 1.1 x U_c	
Drop-out voltage in % of U_c				
			55 %	
Coil consumption				
Average pull-in value				
50 Hz	VA		1900	
60 Hz	VA		1900	
d.c.	W		1700	
Average holding value				
50 Hz	VA/W		48/17	
60 Hz	VA/W		48/17	
d.c.	W		16	
Operating time				
between coil energization and:				
– N.O. contact closing	ms		50 - 80	
– N.C. contact opening			ms	50 - 80
between coil de-energization and				
– N.O. contact opening			ms	35 - 55
– N.C. contact closing	ms		35 - 55	
With PLC				
between coil energization and				
– N.O. contact opening			ms	40 - 65
– N.C. contact closing	ms		40 - 65	
between coil de-energization and				
– N.O. contact opening			ms	10 - 30
– N.C. contact closing	ms		10 - 30	

① 50/60 Hz coils: voltage codes 8 0 to 8 8. see page 1.28.

IEC Technical data

AE9 — AE110

TAE45 — TAE110

Across the line
contactors

1

Magnet System Characteristics for AE... Contactors

Contactor types:	AE...	9	12	16	26	30	40	45	50	63	75	95	110
Rated control circuit voltage U_c	V d.c.	12 ... 250											
Coil operating limits according to IEC 60947-4-1		$\theta \leq 55^\circ\text{C}$ 0.85 ... 1.1 x U_c										$\theta \leq 70^\circ\text{C}$	
Drop-out voltage in % of U_c		roughly 10 ... 30 %						roughly 15 ... 40 %					
Coil consumption - Average values													
- pull-in value	W	90			110			200			400		
- holding value	W	2			2.5			4			2.4		
Coil time constant													
- open	L/R	ms 2			3			3			6		
- closed	L/R	ms 9			16			15			30 ... 40		
Operating time													
between coil energization and:													
- N.O. contact closing	ms	10 ... 16			13 ... 21			13 ... 30			15 ... 25		
- N.C. contact opening	ms	8 ... 12			11 ... 16			10 ... 27			12 ... 22		
between coil de-energization and													
- N.O. contact opening	ms	5 ... 14 ①			6 ... 12 ①			5 ... 15 ①			15 ... 20 ①		
- N.C. contact closing	ms	11 ... 17 ①			8 ... 16 ①			8 ... 18 ①			18 ... 23 ①		

Magnet System Characteristics for TAE... Contactors

Contactor types:	TAE...	-	-	-	-	-	-	45	50	-	75	95	110
Rated control circuit voltage U_c	V d.c.	17 ... 264											
Coil operating limits according to IEC 60947-4-1		$\theta \leq 55^\circ\text{C}$ $U_c \text{ min. ... } U_c \text{ max.}$											
Drop-out voltage in % of $U_c \text{ max.}$		roughly 20 ... 35 %											
Coil consumption values for $U_c \text{ min. ... } U_c \text{ max.}$													
- pull-in value	W							120 ... 250			300 ... 1000		
- holding value	W							1.7 ... 6.5			2 ... 7		
Coil time constant													
- open	L/R	ms						3			6		
- closed	L/R	ms						15			40		
Operating time													
between coil energization and:													
- N.O. contact closing	ms							13 ... 30			15 ... 25		
- N.C. contact opening	ms							10 ... 27			12 ... 22		
between coil de-energization and													
- N.O. contact opening	ms							5 ... 15 ②			15 ... 20 ②		
- N.C. contact closing	ms							8 ... 18 ②			18 ... 23 ②		

① The use of surge suppressors increases the opening time on a scale of 1.1 to 1.5 for a varistor suppressor and on a scale of 4 to 8 for a diode suppressor. AE 9 ... AE 40 contactors and $U_c \geq 110 \text{ V}$: table values for contactors with RV 5 surge suppressor (factory mounted).

② The use of surge suppressors increases the opening time on a scale of 1.1 to 1.5 for a varistor suppressor and on a scale of 4 to 8 for a diode suppressor.

IEC Technical data

A9 — A110

Built-in Auxiliary Contacts - Utilization Characteristics

Contactor types: A...		9	12	16	26	30	40	45	50	63	75	95	110
Rated operational voltage U_e max.	V	690						-	-	-	-	-	-
Conventional free air thermal current I_{th} - $\theta \leq 40$ °C	A	16						-	-	-	-	-	-
Rated frequency limits	Hz	25 ... 400						-	-	-	-	-	-
Rated operational current I_e / AC-15 according to IEC 60947-5-1													
24-127 V 50/60 Hz	A	6						-	-	-	-	-	-
220-240 V 50/60 Hz	A	4						-	-	-	-	-	-
380-440 V 50/60 Hz	A	3						-	-	-	-	-	-
500 V 50/60 Hz	A	2						-	-	-	-	-	-
690 V 50/60 Hz	A	2						-	-	-	-	-	-
Rated operational current I_e / DC-13 according to IEC 60947-5-1													
24 V d.c.	A / W	6 / 144						-	-	-	-	-	-
48 V d.c.	A / W	2.8 / 134						-	-	-	-	-	-
72 V d.c.	A / W	2 / 144						-	-	-	-	-	-
125 V d.c.	A / W	1.1 / 138						-	-	-	-	-	-
250 V d.c.	A / W	0.55 / 138						-	-	-	-	-	-
Rated making capacity acc. to IEC 60947-5-1		10 x I_e / AC-15						-	-	-	-	-	-
Rated breaking capacity acc. to IEC 60947-5-1		10 x I_e / AC-15						-	-	-	-	-	-
Short-circuit protection gG type fuse	A	10						-	-	-	-	-	-
Rated short-time withstand current I_{cw}													
for 1.0 s	A	100						-	-	-	-	-	-
for 0.1 s	A	140						-	-	-	-	-	-
Minimum switching capacity	V / mA	17 / 5						-	-	-	-	-	-
Non-overlapping time between N.O. and N.C. contacts	ms	≥ 2						-	-	-	-	-	-
Insulating resistance at 500 V d.c. after durability test	MOhm	5						-	-	-	-	-	-
Heat dissipation per pole at 6 A	W	0.10						-	-	-	-	-	-

IEC Technical data

A/AE9 — AF/TAE110

Mounting characteristics

Contactor types:	A..., AE... AF..., TAE...	9	12	16	26	30	40	45	50	63	75	95	110
		-	-	-	-	-	-	45	50	63	75	95	110
Mounting positions	see "Conditions for use"												
Mounting distances	The contactors can be assembled side by side												
Mounting													
on DIN rail	35 x 7.5 mm				35 x 15 mm				35 x 15 mm				75 x 25 mm
according to IEC 715 and EN 50022 / EN 50023	35 x 15 mm				75 x 25 mm								75 x 25 mm
by screws (not supplied)	2 x M4				2 x M6								

Conditions for Use

Sustainable utilization conditions for contactors involving at the same time the Mounting position, Ambient temperature and Control voltage operating limits are summarized in the table below.

Contactors	Mounting position	Ambient temperature	Control voltage
A 9 ... A 110, AE 9 ... AE 110	1, 1 ± 30°, 2, 3, 4, 5	≤ 55 °C 55 ... 70 °C	0.85 ... 1.1 x U _c U _c
	6	≤ 55 °C > 55 °C unauthorized	0.95 ... 1.1 x U _c -
AF 45 ... AF 110	1, 1 ± 30°, 2, 3, 4, 5	≤ 70 °C	0.85 U _c min. ... 1.1 x U _c max.
	6 unauthorized	-	-
TAE 45 ... TAE 110	1, 1 ± 30°, 2, 3, 4, 5	≤ 55 °C > 55 °C unauthorized	U _c min. ... U _c max. -
	6 unauthorized	-	-

Notes for 4-pole contactors

Whatever the coil voltage: Pos. 5 unauthorized for A 45-22-00, AE 45-22-00, A 75-22-00, AE 75-22-00 contactors.

For 60 Hz coil voltage: (only for devices fitted with CA 5-.. and CAL 5-11 auxiliary contacts or TP timer)

- A 45-40-00, A 50-40-00 and A 75-40-00 contactors

Mounting positions 1 to 5 and ambient temperature ≤ 55 °C: tolerance reduced to 0.9 ... 1.1 U_c (instead of 0.85 ... 1.1 U_c) for coil voltage codes 7 □ and 8 □.

- A 45-22-00 and A 75-22-00 contactors

Mounting positions 1 to 4 (pos. 5 unauthorized) and ambient temperature ≤ 55 °C: tolerance reduced to 0.9 ... 1.1 U_c (instead of 0.85 ... 1.1 U_c) for coil voltage codes 7 □ and 8 □.

For mounting position 6 or ambient temperature of 55 to 70 °C the information given on this page remains applicable.

Mounting Positions (see the above table for authorized positions)

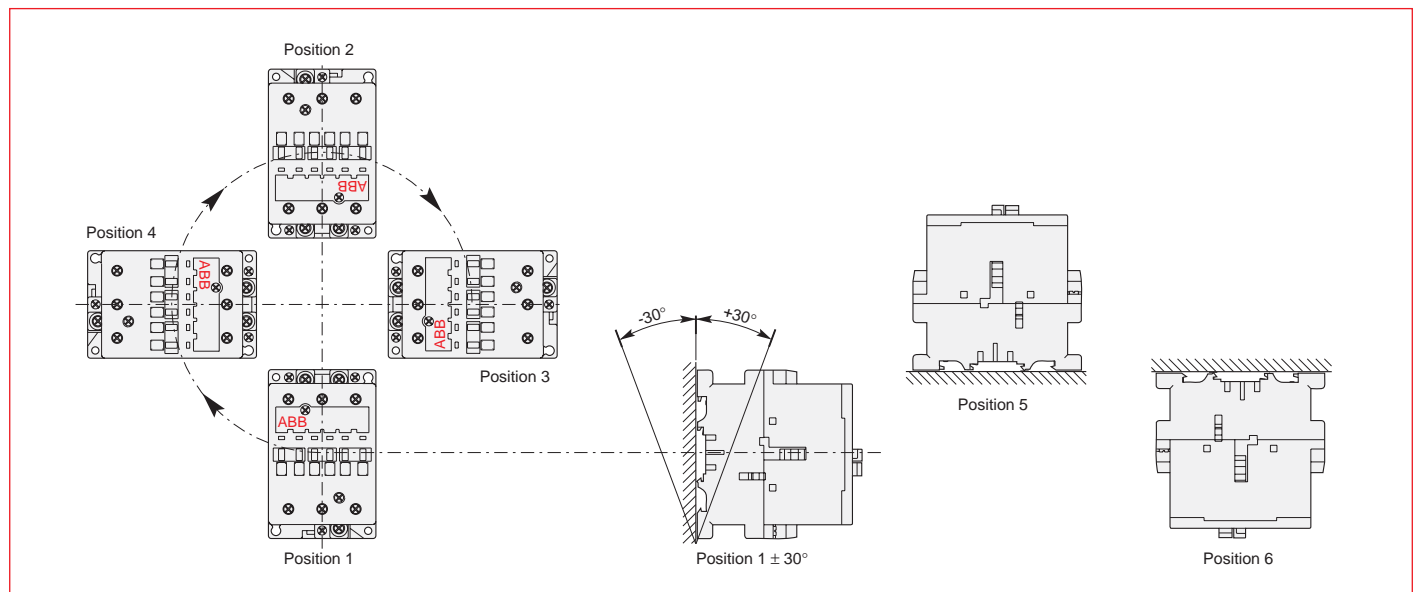

IEC Technical data

A/AF145 — AF1650

Mounting Characteristics — A/AF145 — AF750

Contactor types:	A...	145	185	210	260	300	–	–	–	–
	AF...	145	185	210	260	300	400	460	580	750
Mounting positions	see "Condition for use"									
Mounting distances	The contactors can be assembled side by side									
Fixing										
on DIN rail according to IEC 715 and EN 50022 / EN 50023	–	–	–	–	–	–	–	–	–	–
by screws (not supplied)	4 x M5								4 x M6	

Mounting Characteristics — AF1350 — AF1650

Contactor types:	AF	1350	1650
Mounting positions	see "Condition for use"		
Mounting distances	The contactors can be assembled side by side		
Fixing			
on DIN rail according to IEC 715 and EN 50022 / EN 50023	–	–	–
by screws (not supplied)	4 x M8		

Conditions for Use

Sustainable utilization conditions for contactors involving at the same time the Mounting position, Ambient temperature and Control voltage operating limits are summarized in the table below.

Contactors	Mounting position	Ambient temperature	Control voltage
A 145 ... A 300	1, 1 ± 30°, 2, 3, 4, 5	≤ 70 °C	0.85 ... 1.1 x U _c
	6 unauthorized	–	–
AF 145 ... AF 750	1, 1 ± 30°, 2, 3, 4, 5	≤ 70 °C	0.85 x U _c min. ... 1.1 x U _c max.
	6 unauthorized	–	–

Mounting Positions (see the above table for authorized positions)

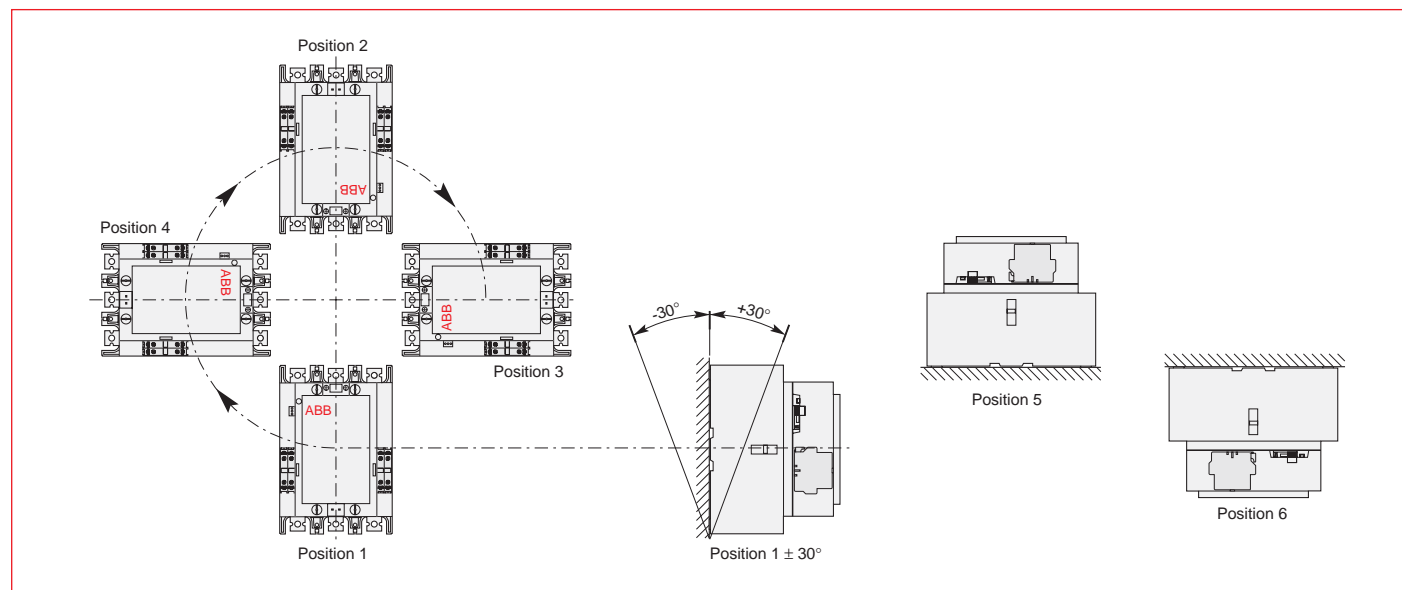









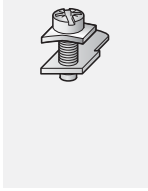
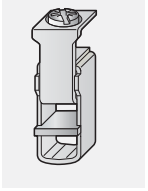
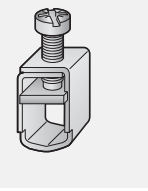
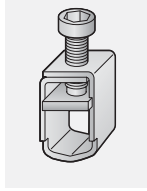







IEC Technical data

A/AE9 — AF/TAE110

Across the line
1

Connecting Characteristics

Contactor types:	A..., AE...	9	12	16	26	30	40	45	50	63	75	95	110
	AF..., TAE...	-	-	-	-	-	-	45	50	63	75	95	110
Main terminals													
													
	with cable clamp					with double connector 2 x (5.6 x 6.5 mm)		with single connector (13 x 10 mm)			with single connector (14 x 14 mm)		
Connecting capacity (min. ... max.)													
Main conductors (poles)													
Rigid: solid ($\leq 4 \text{ mm}^2$)		1 ... 4		1.5 ... 6		2.5 ... 16		6 ... 50			10 ... 95		
stranded ($\geq 6 \text{ mm}^2$)		1 ... 4		1.5 ... 6		2.5 ... 16		6 ... 16			6 ... 35		
Rigid with connector		-		-		-		-			-		
single for Cu cable		-		-		-		-			-		
single for Al/Cu cable		-		-		-		-			-		
double for Al/Cu cable		-		-		-		-			-		
Flexible with cable end		0.75 ... 2.5		0.75 ... 4		2.5 ... 10		6 ... 35			10 ... 70		
		0.75 ... 2.5		0.75 ... 4		2.5 ... 10		6 ... 25			6 ... 35		
Bars or lugs		8		10		-		-			30 ^②		
		3.7		4.2		-		-			6		
Auxiliary conductors													
(built-in auxiliary terminals + coil terminals)													
Rigid solid		1 ... 4									0.75 ... 2.5		
		1 ... 4									0.75 ... 2.5		
Flexible with cable end		0.75 ... 2.5						1 ... 2.5			0.75 ... 2.5		
		0.75 ... 2.5											
Lugs		8		① 10		① 8							
		3.7		① 4.2		① 3.7							
Degree of protection acc. to IEC 60947-1 / EN 60947-1 and IEC 60529 / EN 60529													
Protection against direct contact acc. to VDE 0106 - Part. 100													
- Main terminals	IP 20							IP 10					
- Coil terminals	IP 20												
- Built-in auxiliary terminals	IP 20												
Screw terminals													
(delivered in open position, screws of unused terminals must be tightened)													
Main terminals	(+,-) pozidriv 2 screws										hexagon socket M8 (s = 4 mm)		
	M3.5		M4		M5		M6						
Coil terminals	M3.5 (+,-) pozidriv 2 screws with cable clamp												
Built-in auxiliary terminals	(+,-) pozidriv 2 screws with cable clamp												
	M3.5		M4		M5								
Tightening torque													
Main pole terminals													
- recommended	Nm / lb.in	1.00 / 9		1.7 / 15		2.30 / 20		4.00 / 35			6.00 / 53		
- max.	Nm	1.20		2.20		2.60		4.50			6.50		
Coil terminals													
- recommended	Nm / lb.in	1.00 / 9											
- max.	Nm	1.20											
Built-in auxiliary terminals													
- recommended	Nm / lb.in	1.00 / 9		1.7 / 15		1.00 / 9							
- max.	Nm	1.20		2.20		1.20							
Terminal marking and positioning													
see pages 1.34													

① $L \leq 8$ and $l > 3.7$ for coil terminal - $L \leq 10$ and $l > 4.2$ for built-in auxiliary terminals.
② With LW 110 enlargement piece. See page 1.31.