

TVSS Transient voltage surge suppressors



Transient voltage surge suppressors
TVSS, OVR range



Description

- Compact
- DIN rail mounting
- Broad range
- 1, 2, 3, & 4 pole versions
- Replaceable plug cartridges
- Finger safe
- 15, 40, 65 & 100 kA versions
- Three position visual status indication
- Auxiliary contact for remote signalling
- UL 1449, File # E238957 & E22406

General points on lightning and its risks

Causes of transient overvoltages

The most serious consequences of lightning are the death of people and farm animals, and the destruction of equipment: telephone lines, transformers connected to the electrical distribution network, electrical meters, household appliances, etc.
At the same time, the growing amount of equipment incorporating very sensitive electronic devices increases the number of incidences linked to lightning.

Within companies, if office automation equipment or machines (in factories) are put out of action, it nearly always leads to operating losses, the cost of which is much more than that of the damaged equipment.

For example, if a bank's computers are no longer operational, it suffers large operating losses. For the general public, the damage is mainly material: computer, household appliances, home cinema, etc.

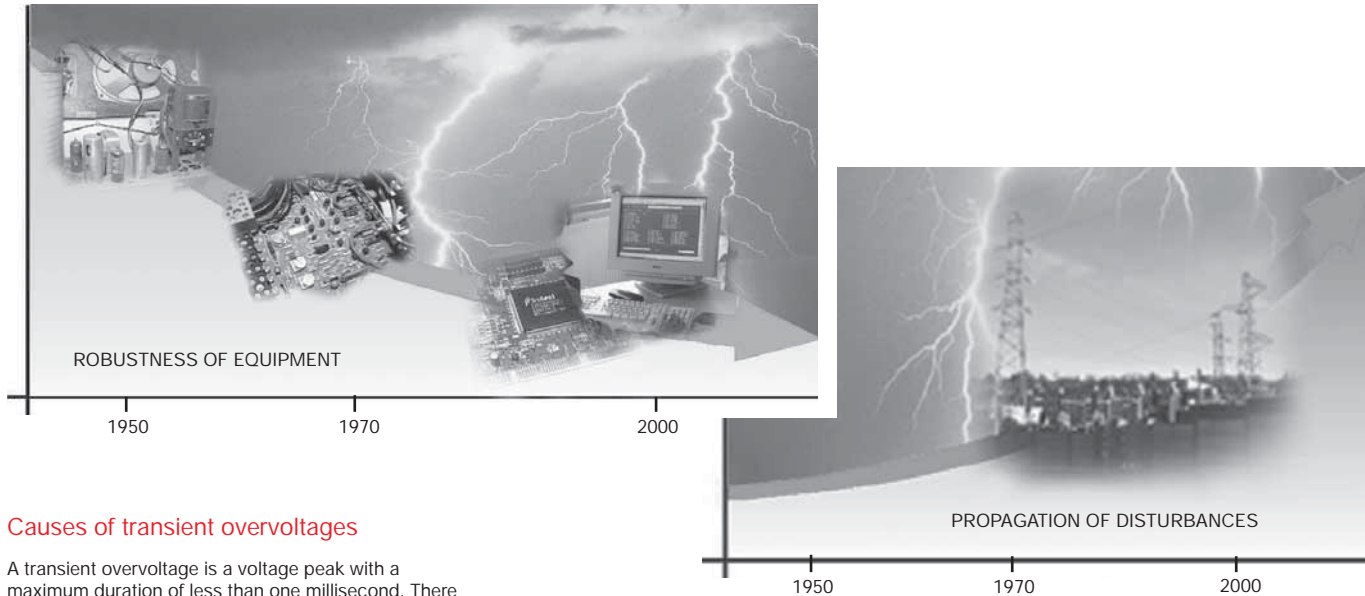

Causes of transient overvoltages

A transient overvoltage is a voltage peak with a maximum duration of less than one millisecond. There are two possible causes of overvoltages on electrical networks:

- natural causes (lightning),
- other causes due to equipment or switching devices.

Natural overvoltages on low voltage networks are caused by direct lightning strikes. The high level of energy contained in a direct lightning strike on a lightning conductor or an overhead low voltage line leads to considerable damage of the installation. The overvoltage can be over 20 times the nominal voltage.

Operating or switching overvoltages linked to a network's equipment create overvoltages of a lower level (3 to 5 times the nominal voltage) but occur much more frequently, thus causing premature ageing of the equipment.

Three categories of overvoltage propagate on low voltage networks:

- direct lightning strikes,
- indirect effects of lightning strikes,
- operating or switching overvoltages.

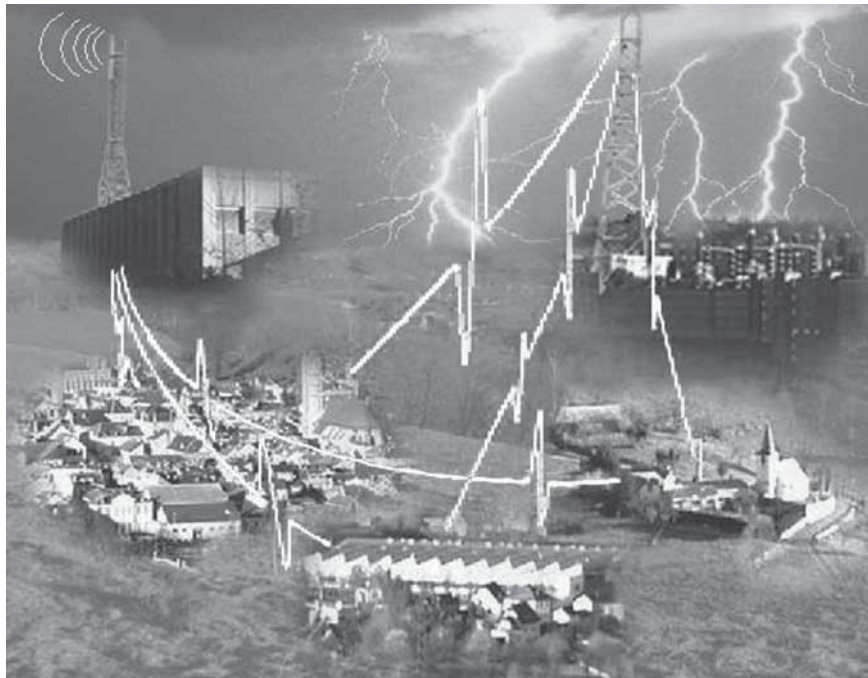

Propagation of overvoltages by electrical networks (power and low current)

General points on lightning and its risks

Causes of transient overvoltages

Overvoltages due to direct lightning strikes

These can take two forms:

- When lightning strikes a lightning conductor or the roof of a building which is earthed, the lightning current is dissipated into the ground. The impedance of the ground and the current flowing through it create large difference of potential: this is the overvoltage. This overvoltage then propagates throughout the building via the cables, damaging equipment along the way.
- When lightning strikes an overhead low voltage line, the latter conducts high currents which penetrate into the building creating large overvoltages. The damage caused by this type of overvoltage is usually spectacular (e.g. fire in the electrical switchboard causing the destruction of buildings and industrial equipment) and results in explosions.



Direct lightning strike on a lightning conductor or the roof of a building



Direct lightning strike on an overhead line

Overvoltages due to the indirect effects of lightning strikes

The overvoltages previously mentioned are also found when lightning strikes in the vicinity of a building, due to the increase in potential of the ground at the point of impact. The electromagnetic fields created by the lightning current generate inductive and capacitive coupling, leading to other overvoltages.

Within a radius up to several kilometres, the electromagnetic field caused by lightning in clouds can also create sudden increases in voltage.

Although less spectacular than in the previous case, irreparable damage is also caused to so called sensitive equipment such as fax machines, computer power supplies and safety and communication systems.



Increase in ground potential



Magnetic field



Electrostatic field

Different types of surges

Equipment containing electronic switching components is also likely to generate electrical disturbances comparable to overvoltages. The consequences of which on sensitive equipment, albeit not visible, are no less detrimental: premature ageing and unpredictable or fleeting breakdowns.

Operating overvoltages are produced when reactive or capacitive equipment is switched on and off. Furthermore, interrupting factory production, lighting or transformers can generate overvoltages which will themselves cause greater damage to nearby electrical equipment.

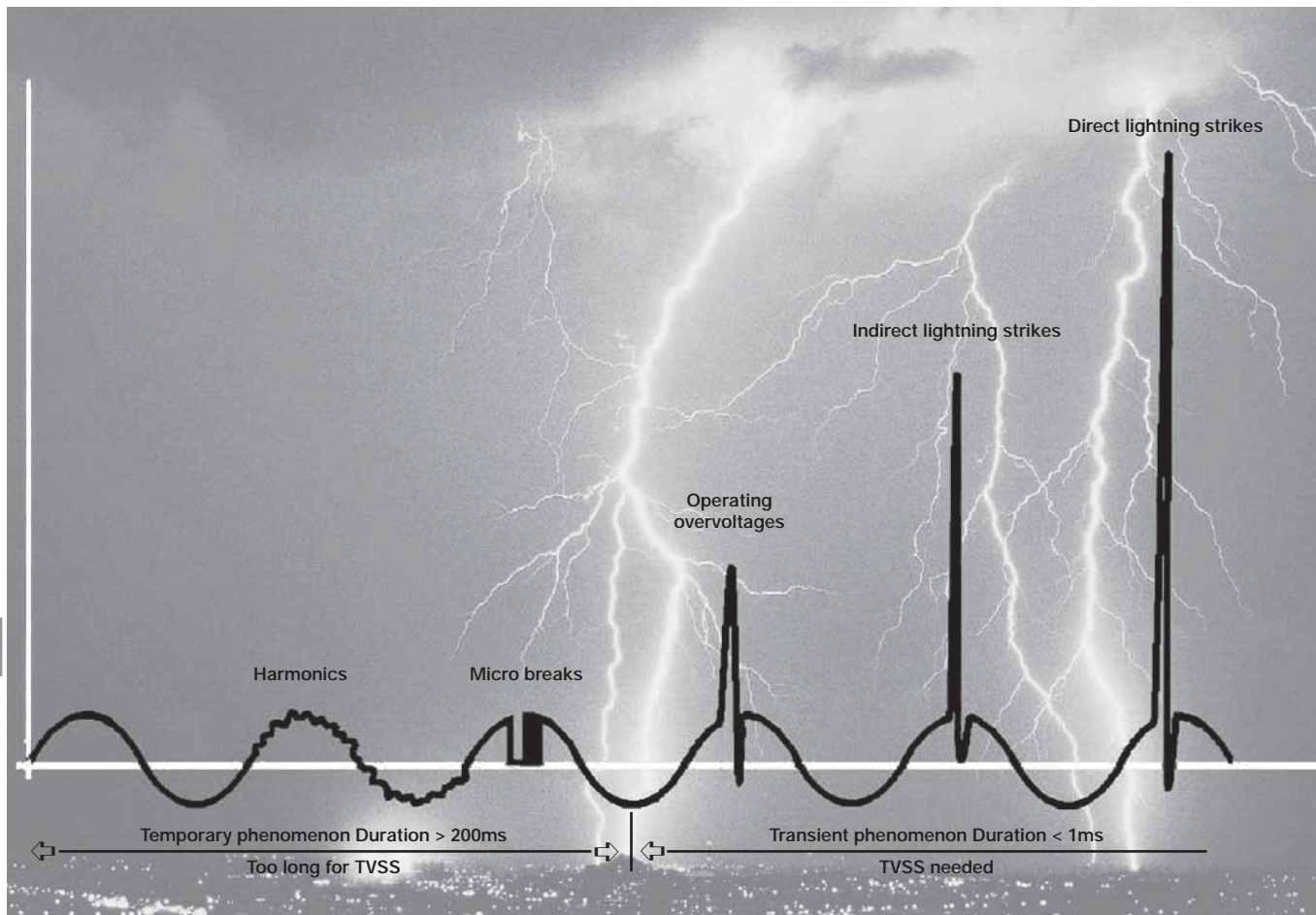

Representation of the various disturbances on electrical networks

Different type of power supply disturbances

- Atmospheric discharges
- Industrial interferences
- Switching operations on the power distribution system

Main effects

- Destruction of the equipment
- Premature aging
- Incorrect operations

OVR Range Main features

TVSSs protect installations by limiting transient overvoltages and run-off lightning currents for electric and electronic equipment.

They are divided into three families:

- **Type 2 TVSSs** provide protection for equipment against transient over-voltage and they are installed in the Main Switch Board (MSB), or in the Sub-Distribution Board (SDB).

In addition to the standard TVSSs, two options are available: the Safety reserve system and the remote indication (TS), in order to ensure a preventive maintenance of the installation.

ABB TVSS (OVR range) offer the same "plus" advantages of the other System pro M compact devices, in order to get a perfect compatibility with all the modular range of products.

All these TVSS products comply with the international standard IEC 61643-1 and the European standard EN 61643-11.

They also comply with UL 1449 and CSA C22.2.



ABB safety reserve system



Contact for alarm connection

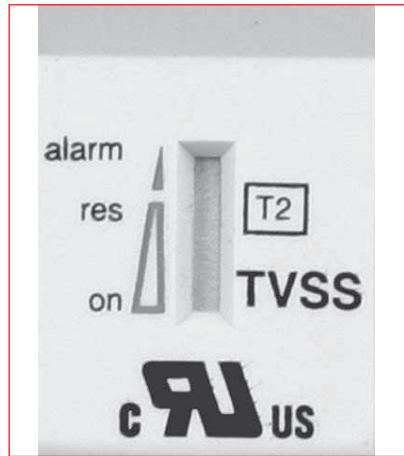
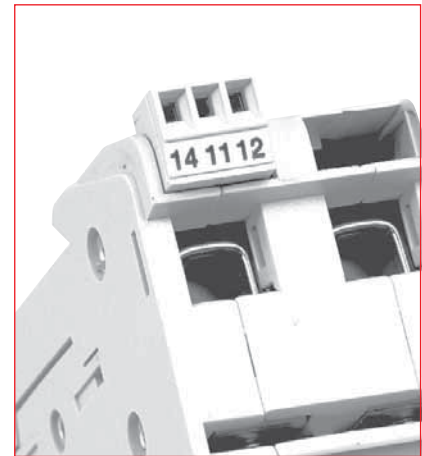
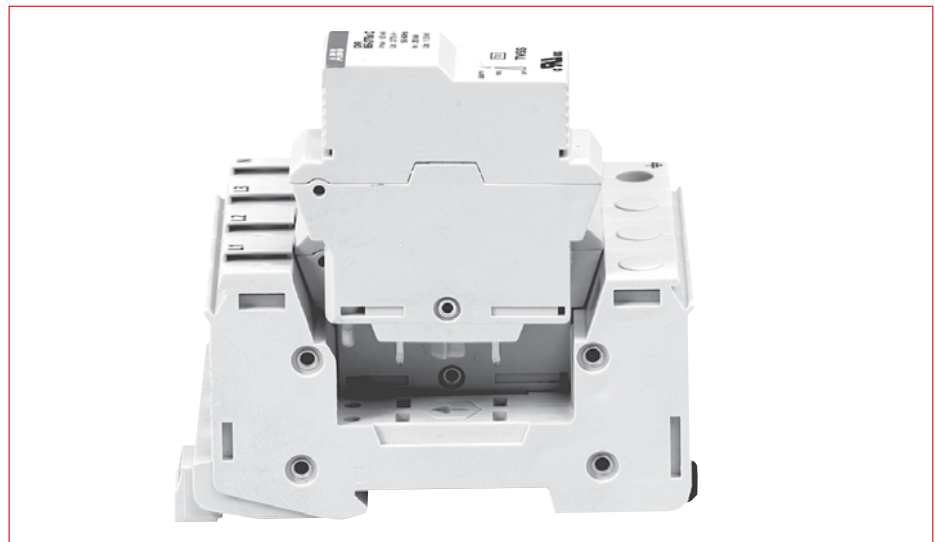

Pluggable unit / replacement modules

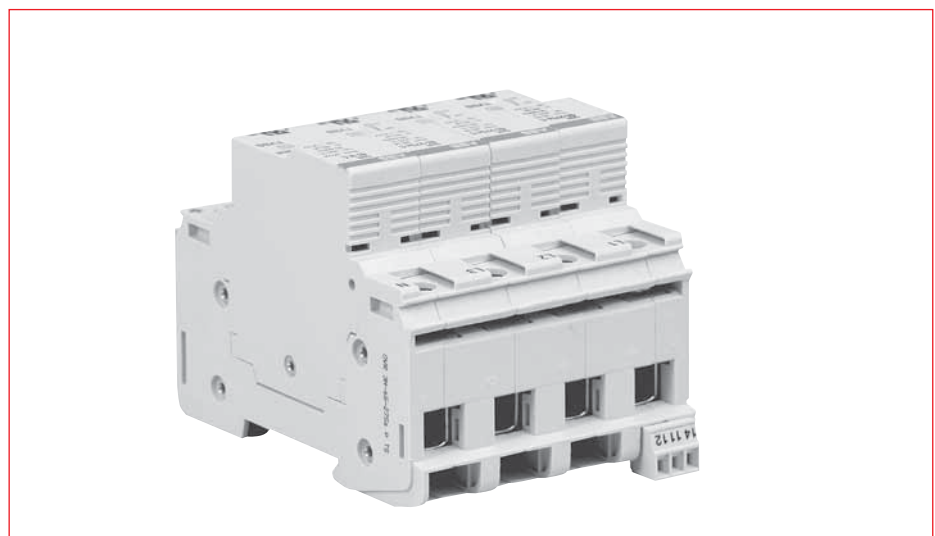

DIN rail unit, easy installation and wiring

Technical data

OVR range



Technical Features				Type 2
Electrical features	Standards			IEC 61643-1 / EN 61643-11 / UL1499 / CSA
	Type / test class			T2 / II
Mechanical features	Poles			1P / 1P+N / 3P / 3P+N / 4P
	Types of networks			TNS - TT - TNC - IT / Wye / Delta
	Type of current			A.C.
	Nominal voltage Un		V	All US network voltages
	Max. cont. operating voltage Uc	(L-N / L-PE / N-PE)	V	150 / 275 / 320 / 440 / 550 / 660
	Voltage protection level Up at In	(L-N / L-PE / N-PE)	kV	0.6 / 1.2 / 1.4 / 1.8 / 2.5 / 2.9
	Nominal discharge current In (8/20)		kA	5 / 15 / 20 / 30
	Maximal discharge current Imax (8/20)		kA	15 / 40 / 65 / 100
	Impulse current Iimp (10/350)		kA	/
	Follow current If		kA	None
	Operating current Ic		mA	< 1
	Short circuit withstand Icc		kA	50
	Disconnecter			
	gG - gL fuse		A	16 - 25
	curve C circuit breaker		A	10 - 40
curve K circuit breaker				
Installation	Stocking temperature		°C	-40 to +80
	Operating temperature		°C	-40 to +80
	Degree of protection			IP 20
	Fire resistance according to UL 94			V2
	Material of Housing			PC grey RAL 7035
	Maximal altitude		m	2000
	Integrated thermal disconnecter			Yes
	State indicator			Yes
	Compatibility with OVR Sign			Yes
	Safety reserve			Option
TS remote indicator			Option	
Dimensions and weight	Wire range L/N			
	solid wire		mm ²	2.5 ... 25
	stranded wire		mm ²	2.5 ... 16
	Stripping length L/N		mm	12.5
	Tightening torque L/N		Nm	2
	Wire range PE			
	solid wire		mm ²	2.5 ... 25
	stranded wire		mm ²	2.5 ... 16
Stripping length PE		mm	12.5	
Tightening torque PE		Nm	2	
Electrical features	Pole dimensions (H x D x W)		mm	85 x 58 x 17.5
	Pole weight		g	120
Electrical features	Technical Features of the integrated auxiliary contact			
	Contact complement			1NO (1 make contact), 1NC (1 normally closed contact)
Installation	Min. load			12V D.C. - 10 mA
	Max. load			250V A.C. - 1A
Installation	Connection cross-section		mm ²	1.5

OVR Range Single pole

Transient voltage
surge suppressors



Transient voltage surge suppressor

Function: TVSS provides protection for equipment against transient overvoltage (indirect lightning strike) that occur on the electrical network (mains); the maximum discharge current (I_{max}) ranges from 15 to 100 kA per pole, based on MOV technology.

Application: residential, commercial, industrial
Standard: CEI 61643-1 / EN 61643-11 / UL 1449 / CSA
8/20 current wave

Type 2 - Surge Protection Devices – Single pole

Max Discharge Current (kA)	Nominal Voltage (V)	MOV Voltage (V)	Voltage Protection Level Up (KV)	Catalog number	List price
15	120	150	.06	OVR 15 150 OVR 15 150 s P	\$ 230 350
	230	275	1.2	OVR 15 275 OVR 15 275 P TS	220 340
	277	320	1.4	OVR 15 320	220
	400	440	1.8	OVR 15 440 OVR 15 440 P	220 350
	480	550	2.5	OVR 15 550	275
	600	660	2.9	OVR 15 660	290
40	120	150	0.6	OVR 40 150 s P OVR 40 150 s P TS	440 510
	230	275	1.2	OVR 40 275 P OVR 40 275 s P OVR 40 275 s P TS	320 345 400
	277	320	1.4	OVR 40 320 P OVR 40 320 s P OVR 40 320 s P TS	320 350 405
	400	440	1.8	OVR 40 440 OVR 40 440 s P OVR 40 440 s P TS	285 350 400
	480	550	2.5	OVR 40 550 OVR 40 550 s	435 475
	600	660	2.9	OVR 40 660 s	490
65	120	150	0.6	OVR 65 150 s P	395
	230	275	1.2	OVR 65 275 s P OVR 65 275 s P TS	490 565
	277	320	1.4	OVR 65 320 s P OVR 65 320 s P TS	495 520
	400	440	1.8	OVR 65 440 s P OVR 65 440 s P TS	465 530
	480	550	2.5	OVR 65 550 s	600
	600	660	2.9	OVR 65 660 s	675
100	230	275	1.2	OVR 100 275 s P OVR 100 275 s P TS	830 955
	277	320	1.4	OVR 100 320 s P OVR 100 320 s P TS	890 1025
	400	440	1.8	OVR 100 440 s OVR 100 440 s P OVR 100 440 s P TS	800 870 1005

14

OVR 1N 65 275 s P TS

Network

- 1N Single phase (left), neutral (right)
- 3N Three phase (left), neutral (right)
- N1 Neutral (left), single phase (right)
- N3 Neutral (left), three phases (right)
- 3L Three poles
- 4L Four poles
- Nothing Single pole

Max. discharge current 8/20

I_{max} (kA)	15
	40
	65
	100

TS Integrated remote indication

P Pluggable unit
Nothing: Single block

s with safety reserve

Max. continuous operating voltage

U_c (V)	660
	550
	440
	385
	320
	275
	150
	75

OVR TVSS Multi-pole



Transient voltage surge suppressor

Function: TVSS provides protection for equipment against transient overvoltage (indirect lightning strike) that occur on the electrical network (mains); the maximum discharge current (I_{max}) ranges from 15 to 100 kA per pole, based on MOV technology.

Application: residential, commercial, industrial
Standard: CEI 61643-1 / EN 61643-11 / UL 1449 / CSA
8/20 current wave

Max Discharge Current (kA)	Nominal Voltage (V)	MOV Voltage (V)	Voltage Protection Level Up (kV)	Catalog number	List price				
15	120	150	0.6	OVR 1N 15 150	\$ 365				
				OVR 1N 15 150 s P TS	665				
				OVR 3N 15 150	625				
40	230	275	1.2	OVR 3L 15 275 P	625				
				OVR 3N 15 275	690				
				OVR 3N 15 320	980				
65	120	150	0.6	OVR 1N 40 150 s P	665				
				OVR 1N 40 150 s P TS	935				
				OVR 3N 40 150 s P TS	1160				
				OVR 3N 40 275 s P	1120				
100	230	275	1.2	OVR 3L 40 275 s P	950				
				OVR 3N 40 320 P	1175				
				OVR 3N 40 320 s P	1250				
				OVR 3N 40 320 s P TS	1450				
100	400	440	1.8	OVR 3N 40 440 s P	1290				
				65	120	150	0.6	OVR 1N 65 150 s P	1000
								OVR 3N 65 150 s P	1535
								OVR 3N 65 150 s P TS	1640
OVR 3L 65 275 s P	1045								
100	230	275	1.2	OVR 3N 65 275 s P	1280				
				65	120	150	0.6	OVR 3N 65 320 s P	1650
								OVR 3N 65 320 s P TS	1900
								OVR 3N 65 440 s P	1245
OVR 4L 65 440 s	1320								
100	277	320	1.4	OVR 3N 100 320 s P	3200				
				OVR 3N 100 320 s P TS	3600				

OVR 1N 65 275 s P TS

Network

1N Single phase (left), neutral (right)
3N Three phase (left), neutral (right)
N1 Neutral (left), single phase (right)
N3 Neutral (left), three phases (right)
3L Three poles
4L Four poles
Nothing Single pole

Max. discharge current 8/20

I_{max} (kA) 15
40
65
100

L TS Integrated remote indication

P Pluggable unit
Nothing: Single block

s with safety reserve

Max. continuous operating voltage

U_c (V) 660
550
440
385
320
275
150
75

OVR Range

Very low voltage transmission lines protection



OVR TC 06 V



OVR TC 200 FR

Transmission line surge arresters (OVR TC) provide protection against transient overvoltages for equipment connected to telephone lines (digital or analog) & current loops.

Standards Info:
Modular low current surge arresters comply with IEC 61643-21 / UL 1449.

Schematic diagrams

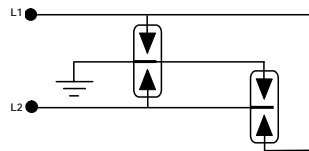

OVR TC 200 V in parallel

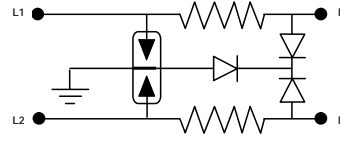

OVR TC / xx V / 200 FR in series

Dimensions

Dimensions (mm)	W	H	D
OVR TC (all models)	17,5	85	63

Connection

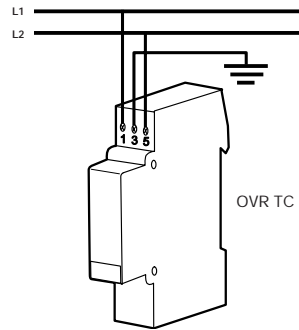

OVR TC 200 V in parallel

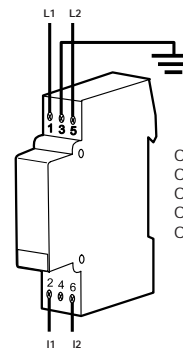

OVR TC / xx V / 200 FR in series

OVR TC 200 FR
OVR TC 48 V
OVR TC 24 V
OVR TC 12 V
OVR TC 06 V

Fixing

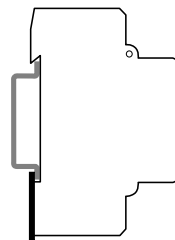

Simply clips onto DIN rail.

Practical info:
Telecom and dataline protection surge arresters are installed in electrical switchboards or enclosures using DIN rail.

Technical data

Electrical characteristics	6 V	12 V	24 V	48 V	200 V	200 V
	OVR TC 06 V	OVR TC 12 V	OVR TC 24 V	OVR TC 48 V	OVR TC 200 V	OVR TC 200 FR
Types of network	Communication	Communication	Communication	Communication	Communication	Communication
Number of pairs	1	1	1	1	1	1
Type of protection	Series	Series	Series	Series	Parallel	Series
Type of current	Low currents	Low currents	Low currents	Low currents	Low currents	Low currents
Nominal voltage: U_n	6 V	12 V	24 V	48 V	200 V	200 V
Max cont operating voltage: U_c	7 V	14 V	27 V	53 V	220 V	220 V
Voltage protection level: U_p at I_n	15 V	20 V	35 V	70 V	700 V	300 V
Nominal discharge current: I_n (8/20)	5 kA	5 kA	5 kA	5 kA	5 kA	5 kA
Maximum discharge current: I_{max} (8/20)	10 kA	10 kA	10 kA	10 kA	10 kA	10 kA
Bandwidth	10 MHz	2 MHz	4 MHz	6 MHz	100 MHz	3 MHz
Operating current: I_c	20 mA	20 mA	20 mA	20 mA	-	20 mA
Degree of protection	IP 203	IP 203	IP 203	IP 203	IP 203	IP 203
50 Hz withstand (15 mn)	10 A	10 A	10 A	10 A	-	10 A
Mechanical characteristics						
L/N connection terminals:						
- solid wire	0.5 ... 2.5 mm ²					
- stranded wire	0.5 ... 2.5 mm ²					
PE connection terminal:						
- solid wire	0.5 ... 2.5 mm ²					
- stranded wire	0.5 ... 2.5 mm ²					
Integrated thermal disconnecter		Yes			No	Yes
End of life indicator		Yes			No	Yes
Compatibility with OVR Sign		Yes			No	Yes
Miscellaneous characteristics						
Storage temperature	-40 °C to +80 °C					
Operating temperature	-40 °C to +80 °C					
Maximum altitude	2000 m					
Case material	PC grey RAL 7032					
Insulating material	UL94 V0 classification					
Reference standard	IEC 61643-21 / UL 1449					
Weight	150 g					

Installation rules

Principles of coordination for TVSS

The first surge arrester does not provide effective protection for the whole installation by itself. Certain electrical phenomena can double the protection's residual voltage if cable lengths exceed 10m. Surge arresters must be coordinated when they are installed refer to the tables below.

Coordination required if:

The first surge arrester does not reach the protection voltage (U_p) by itself.
The first surge arrester is more than 10m away from the equipment to be protected.

The first surge arrester diverts most of the current to the ground and the remaining surge current is diverted to the ground by the second surge arrester.

The value of this remaining surge current gets lower as the distance between both surge arresters gets longer. The lower is the current going through the last surge arrester, the lower is the voltage protection level applied to the downstream equipment.

Coordination between Type 2 TVSS units

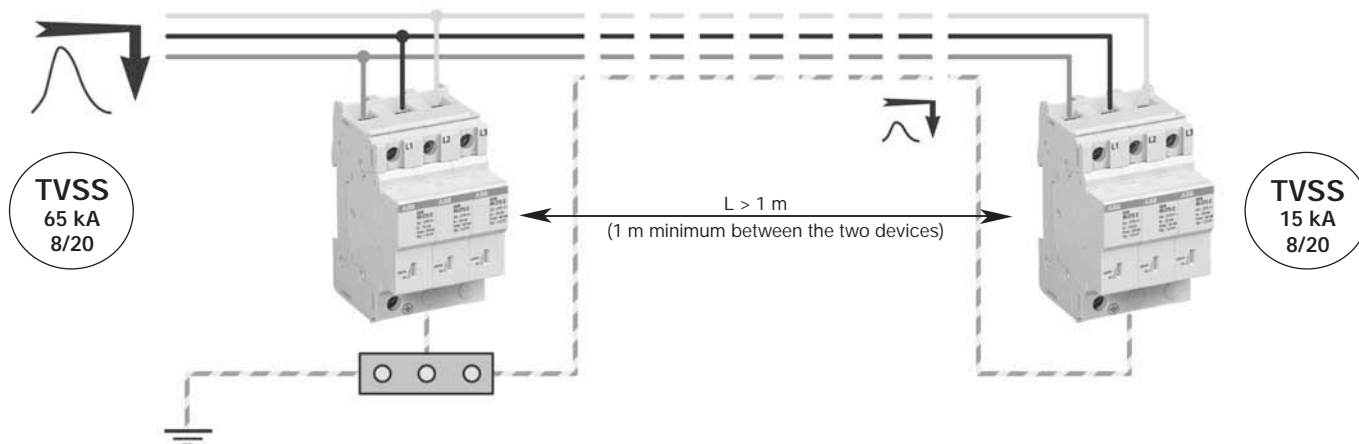

Approximate dimensions OVR range



Transient voltage surge suppressor

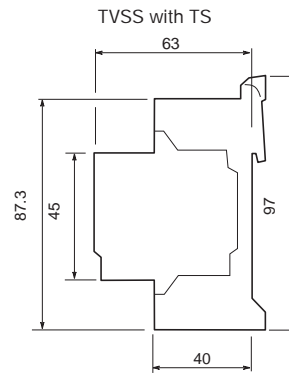
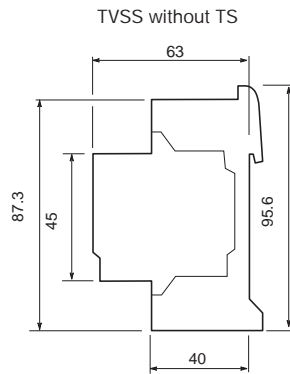

1 pole



OVR 15 275 P
OVR 15 440 P
OVR 40 275 P
OVR 40 275 s P TS
OVR 40 440 P
OVR 40 440 s P TS
OVR 65 275 s P TS
OVR 65 440 s P TS

3 poles

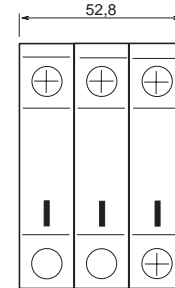

OVR 3L 15 275 P
OVR 3L 40 275 P
OVR 3L 40 275 s P TS
OVR 3L 65 275 s P TS

4 poles

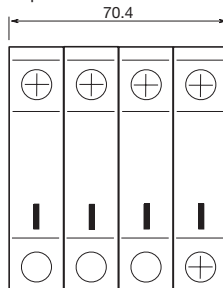

OVR 4L 15 275 P
OVR 4L 40 275 P
OVR 4L 40 275 s P TS
OVR 4L 65 275 s P TS

3 poles + Neutral

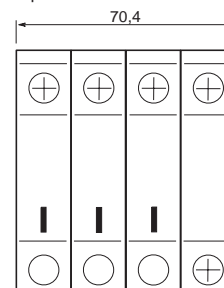

OVR 3N 15 275 P
OVR 3N 40 275 P
OVR 3N 40 275 s P TS
OVR 3N 65 275 s P TS

Technical details

Installation rules for TVSS choice of associated breaking devices (fuse/circuit breaker)

Choice of disconnecter

Surge arresters must be associated with upstream short-circuit protection and residual current protection against indirect contact (usually already present in the installation)

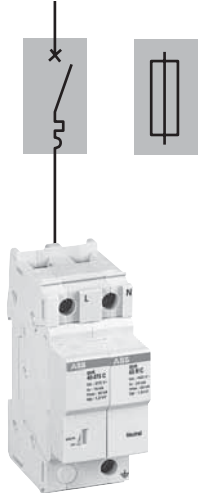
	Function	Application
	Protection against fault currents	The breaking device associated with the surge arrester can be either a circuit breaker or a fuse. Its rating should take into consideration the surge arrester's characteristics and the short-circuit current of the installation.
	Thermal protection	Thermal protection is integrated into the surge arrester.

Maximum circuit-breaker or fuse protection rating depending on I_{max} and I_{imp} of the surge arrester.

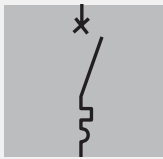
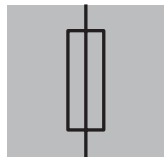
	 Circuit-breaker (curve K)	 Fuse (gG)
TVSS surge arresters 100 kA (8/20) <ul style="list-style-type: none"> I_{cc} = 300 A to 1 kA I_{cc} = 1 kA to 7 kA I_{cc} = 7 kA and above 	40 A 40 A 40 A	25 A 25 A 25 A
TVSS surge arresters 65 kA (8/20) <ul style="list-style-type: none"> I_{cc} = 300 A to 1 kA I_{cc} = 1 kA to 7 kA I_{cc} = 7 kA and above 	30 A 32 A to 40 A 32 A to 63 A	20 A 40 A 63 A
40 kA (8/20) <ul style="list-style-type: none"> I_{cc} = 300 A to 1 kA I_{cc} = 1 kA to 7 kA I_{cc} = 7 kA and above 	25 A 25 A 25 A to 50 A	16 A 25 A 50 A
15 kA (8/20) <ul style="list-style-type: none"> I_{cc} = 300 A to 1 kA I_{cc} = 1 kA to 7 kA I_{cc} = 7 kA and above 	10 A to 25 A 10 A to 32 A 10 A to 40 A	16 A 16 A 25 A to 40 A

Technical details

Cabling and installation of Surge Protection Devices in an electrical panel

50 cm rule

Remember that a 10 kA lightning current passing through a 1 m length of cable generates 1000 Volts. Equipment protected by a surge arrester is subjected to a voltage equal to the sum of the U_p voltage of the surge arrester, U_o of its disconnector and the sum of the inductive voltages of connecting cables ($U_1+U_2+U_3$). It is therefore essential that the total length ($L = L_1+L_2+L_3$) of the connecting cables is as short as possible (0.50 m).

If this length ($L = L_1 + L_2+L_3$) exceeds 0.50m, it is necessary to carry out one of the following:

- Reduce this length by moving the connection terminals.
- Choose a surge arrester with a lower U_p value.
- Install a second, coordinated surge arrester near the device to be protected so as to adapt the combined U_p value to the impulse withstand of the equipment to be protected.

Wiring ring surfaces

The wires must be arranged in such a way that they are as close to each other as possible (see adjacent diagram) to avoid overvoltages induced by a ring surface between phases, the neutral and the PE conductor.

Routing of clean cables and polluted cables

During installation, lay clean cables (protected) and polluted cables as shown in the adjacent diagrams.

To avoid magnetic coupling between the different cable types (clean and polluted), it is strongly advised that they are kept apart (> 30 cm) and if a crossing cannot be avoided, it should be at right angles (90°).

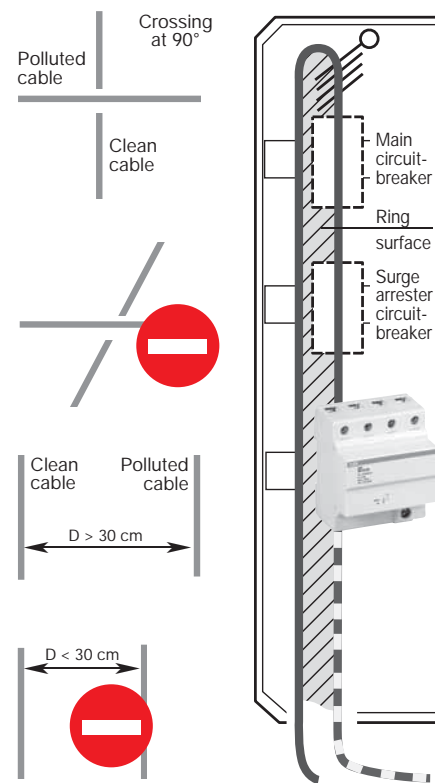
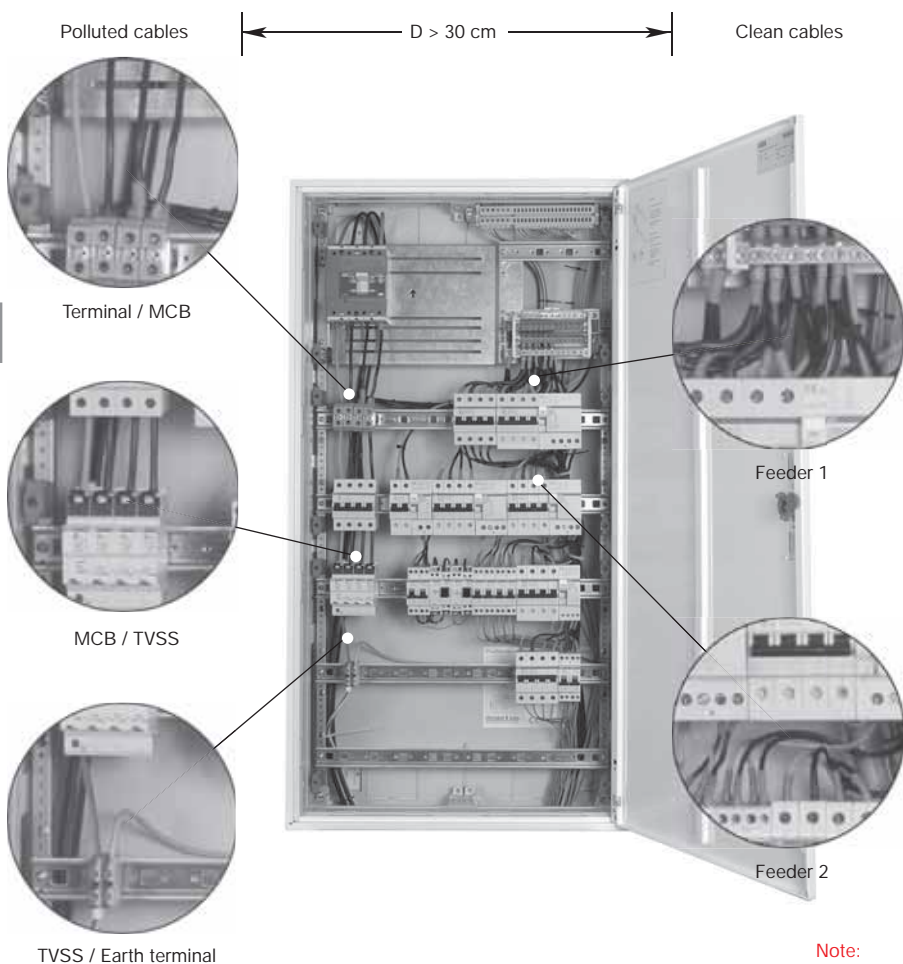
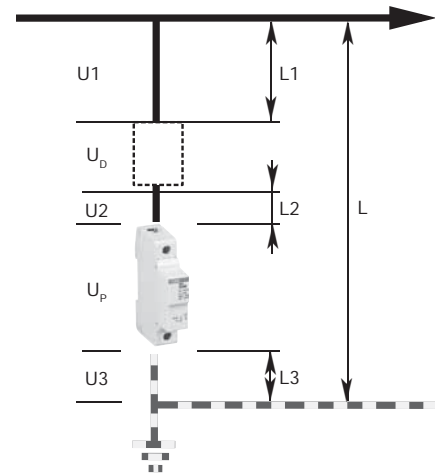

Note:

The cross-section of the connecting cables is calculated according to the local short-circuit current level (where the surge arrester is installed). It must be equal to the cross-section of the installation's upstream cables.

The minimum cross-section for the earth conductor is 4 mm² if there is not a lightning conductor and 10 mm² if there is a lightning conductor.

Application sheets OVR Surge Protection Devices



Operating principle

The Surge Protection Devices (TVSS), suitable for residential, commercial and industrial applications, are designed to limit transient overvoltage and run-off lightning currents.

Application environments

The Surge Protection Devices (TVSS) are necessary in any environment where the lightning risk exists (direct lightning strike / overvoltage).

Example of installation

As shown in the diagrams, one of the possible applications is to protect the equipment (TV, computer, ...) against overvoltage thanks to a Surge Protection Device (TVSS) which ensures the protection in common mode (Ph-PE / N-PE) and differential mode (Ph-N).

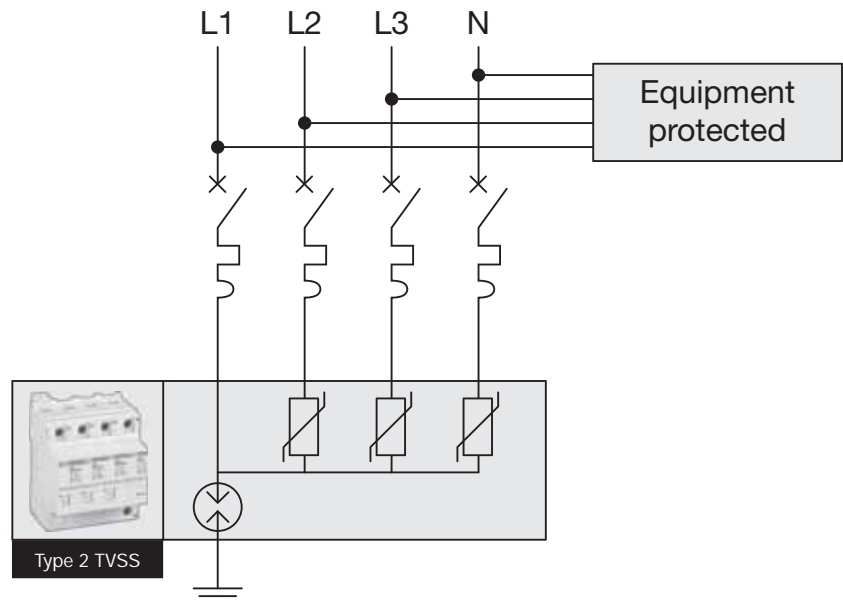
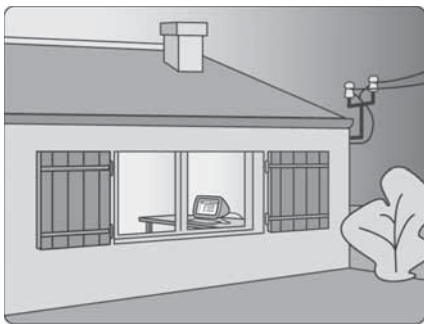

General points on lightning and its risks

Diagram of an installation protected against lightning and its indirect effects

The 100KA or 65KA surge arrester (depending on the lightning risk) fitted in the installation's main incoming electrical switchboard, is capable of deviating the energy of a direct lightning strike. This is the first stage of the electrical network's protection.

The behaviour of the cables, subjected to a transient signal, limits the effectiveness of a surge arrester to 10 m of cable. It is therefore necessary to use one or more surge arresters in the installation in order to obtain the required level of protection for the equipment.

Here, a 40KA or 15KA surge arrester (depending on the lightning risk) should be used in coordination with the incoming surge arrester. This is the second stage of the protection.

Finally, if there is a risk of overvoltage on the electrical network, this risk also exists for the auxiliary wiring network. The appropriate protection is a surge arrester designed to protect telephone or data transmission lines (**OVR TC**). This is fitted in series on the network.

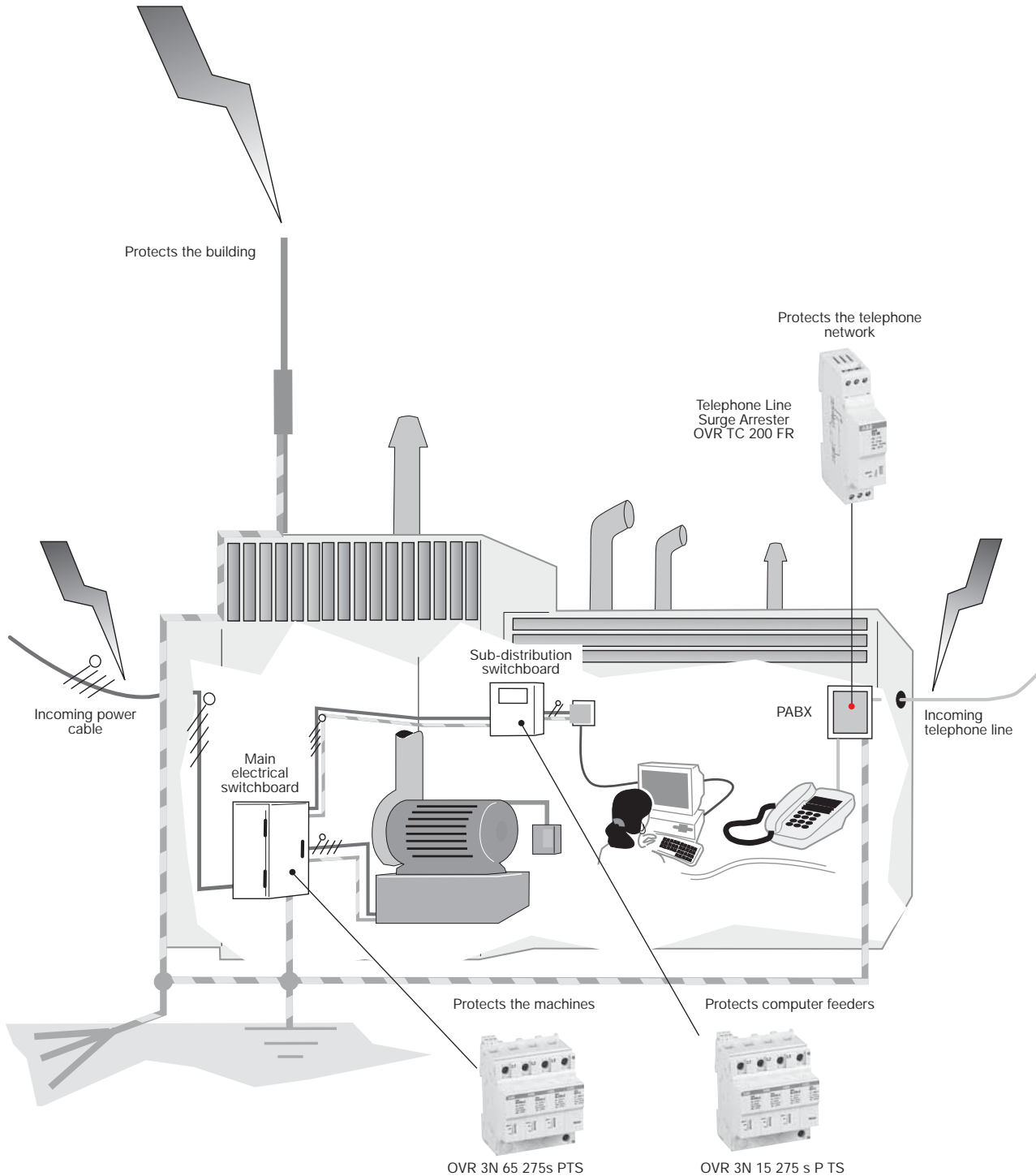

Selection

Example of a protected industrial installation

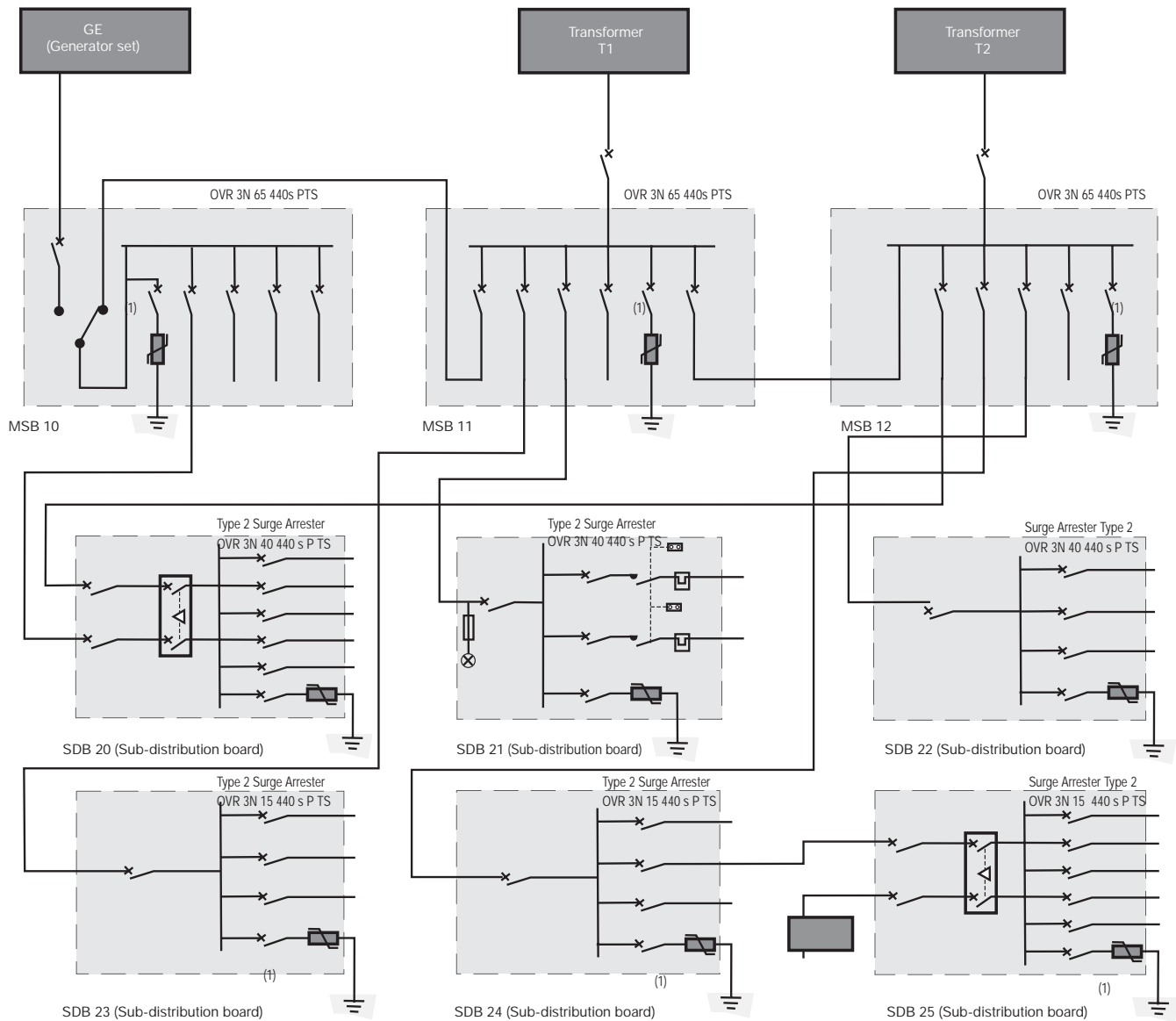

The above diagram is an example of an industrial application located in an area where the lightning strike density (N_g) is 1.2 lightning strikes per km^2 and per year:

- the building is protected by a lightning conductor.
- the lightning conductor's earthing strip is connected to the installation's earth network.
- the earthing system is IT (with distributed neutral) and then TNS for the sub-distribution boards.
- main switch boards (MSB) 10, 11 and 12 are fitted with Type 2 surge arresters OVR 3N 65 440 s PTS.
- sub-distribution boards (SDB) 20, 21 and 22 are fitted with Type 2 surge arresters OVR 3N 40 440 s P TS.
- sub-distribution boards (SDB) 23, 24 and 25 are fitted with Type 2 surge arresters OVR 3N 15 440 s P TS.

Surge arrester:

Device designed to limit transient overvoltages and run-off lightning currents. It consists of at least one non-linear component. It must comply with European standard EN 61643-11.

1.2/50 wave:

Standardized overvoltage waveform created on networks and which adds to the network's voltage.

8/20 wave:

Current waveform which passes through equipment when subjected to an overvoltage.

Type 2 surge arrester:

Surge arrester designed to run-off energy caused by an overvoltage comparable to that of an indirect lightning strike or an operating overvoltage. It has successfully passed testing to the standard with the 8/20 wave (class II test).

U_p :

Voltage protection level / Let through voltage

Parameter characterising surge arrester operation by the level of voltage limitation between its terminals and which is selected from the list of preferred values in the standard. This value is greater than the highest value obtained during voltage limitation measurements (at I_n).

I_n :

Nominal discharge current.

Peak current value of an 8/20 waveform (15 times) flowing in the surge arrester. It is used to determine the U_p value of the surge arrester.

I_{max} :

Maximum discharge current for class II testing.

Peak current value of an 8/20 waveform flowing in the surge arrester with an amplitude complying with the class II operating test sequence.

14 I_{max} is greater than I_n .

U_n :

Nominal AC voltage of the network : nominal voltage between phase and neutral (AC rms value).

