

Arc monitor • Current sensing unit

Arc Guard Systems

ABB Arc Guard Systems
Arc monitor
Current sensing unit
Accessories



Arc monitor

- Available for AC and DC power
- Photodiodes for sensing light
- The two output stages are triacs triggered via a pulse transformer
- Two separate relay outputs
- A switch is included for selection of automatic relay resetting
- A digital display, visible through the window in the door, is lighted when the triac outputs are activated and shows which detector has caused tripping
- Terminals are provided for connection of the arc monitor's own power supply and for connections to the circuit-breaker trip coil
- The power consumption of the unit is approximately 6 watts

Current sensing unit

- Has terminals for a number of different supply voltages
- Connects to current transformers located at suitable positions in the busbar system of the installation to be monitored
- Incorporates a selector switch and potentiometer for testing and checking purposes
- Power consumption approximately 11 W
- Optical signal transmission
- Can be connected in series using optical cables
- LEDs indicate when the current exceeds approximately 70% and 100% of the set value
- The unit can be either 1, 2 or 3-phase connected (to one, two or three current transformers)
- Imposes insignificant load on the current transformers, approximately 0.7 VA, so current transformers that are also applied for other purposes can often be used

Ordering information

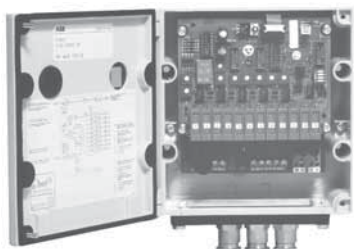

AGS-AM240



AGS-CS240

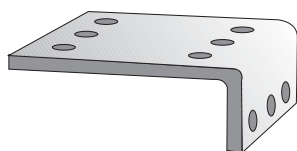

AGS-MB



AGS-FMS

Arc monitor

Power supply voltage	Catalog number	List price
60 – 220 VDC and 60 – 240 VAC, 50 – 60 Hz 24 – 48 VDC	AGS-AM240 AGS-AM48	\$ 3843

Receives the light signal sent by the detector via fiberoptic cables and sends a trip signal to the upstream circuit breaker within 1-2 ms. The DC powered design has reverse polarity protection.

Current sensing unit

Power supply voltage	Catalog number	List price
24, 48, 60, 110, 125 and 220 VDC 110 – 125 VAC and 240 VAC, 50 – 60 Hz	AGS-CS240	\$ 2452

Provides a safeguard against nuisance tripping by requiring both a rapid change in current as well as a signal from the light detector before a trip signal can be transmitted to the upstream circuit.

Detectors with optical plastic cable ①

Cable length	Catalog number	List price
2m	AGS-DP2	\$ 212
4m	AGS-DP4	235
6m	AGS-DP6	260
8m	AGS-DP8	289
10m	AGS-DP10	314
15m	AGS-DP15	381
20m	AGS-DP20	448
30m	AGS-DP30	591

The detectors transfer light from the arc via the fiberoptic cable to the Arc Monitor.

Optical fiber cable — plastic (provided with plug-in socket terminals) ①

Cable length	Catalog number	List price
0.5m	AGS-CP.5	\$ 84
1m	AGS-CP1	92
2m	AGS-CP2	105
4m	AGS-CP4	134
6m	AGS-CP6	160
8m	AGS-CP8	189
10m	AGS-CP10	214
15m	AGS-CP15	281
20m	AGS-CP20	356

For connection between units: • current sensing unit to arc monitor • arc monitor to arc monitor.

Mounting bracket

Application	Catalog number	List price
For mounting detectors. Detectors are secured to the bracket by means of cable straps.	AGS-MB	\$ 10

Flush mounting set

Application	Catalog number	List price
For arc monitor and current sensing unit mounting in switchgear front.	AGS-FMS	\$ 128

① Detectors and optical cables using fiber glass can be supplied upon request — consult factory for pricing.

ABB General description

Arc Guard System

Arc monitor

Current sensing unit

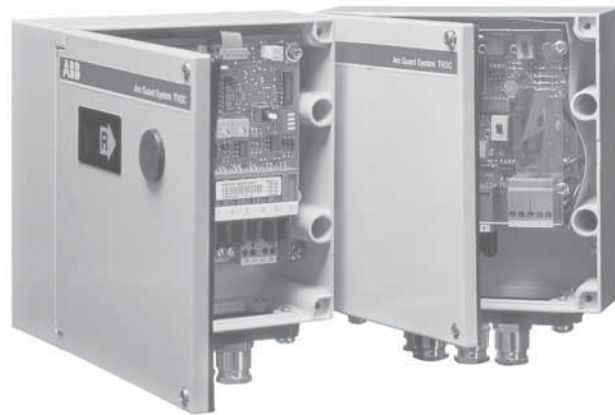

Function

The purpose of the arc guard system is to quickly disconnect the energy source if an arcing fault should occur. The watchful eye of the arc monitor detects any large increase in light intensity. The detector transfers light from the arc through a state-of-the-art solid state electronics package. Within an interval of one to two milliseconds, the detector sends a trip signal to the disconnecting upstream circuit breaker located in the switchgear, bypassing delays caused by the selective features of relaying schemes. This protects your equipment and personnel.

Current sensing unit

The detectors can also be sensitive to other forms of intense light, such as camera flashes, lightning, direct sunlight, switching arcs in circuit breakers and other large apparatus. By combining the arc monitor with a current sensing unit set just over the normal operating level, a current dependent condition is introduced which prevents triggering from irrelevant light sources. This prevents nuisance tripping the switchgear and causing an unintentional power outage.

Insensitivity to interference

A switchgear environment is often subjected to extreme electromagnetic interference, especially during an arcing fault. High currents in the busbars and cables, switching arcs in contactors and circuit breakers generate fields that interfere with communication between

relays and meters. Fiber optic cables eliminate the risk of electromagnetic interference. All communication between the detectors, arc monitor and the current sensing unit are through fiber optics. Fiber optic signal transmission makes the systems immune to interference.

System security

The arc guard system is a product that seldom (or never!) has to take action, but which must then always operate with absolute dependability. Its performance should be checked after installation and subsequently at certain intervals, e.g. once a year. The design of the system makes it easy to check. The procedure is described in the instructions provided with the equipment.

Approvals

- Underwriters Laboratories
File #E155370
- Factory Mutual system
Reference FMRC J.I. 1B1A4.AF
- Lloyds Register of Shipping
Cert. #97/00189
- Det Norske Veritas
Cert. #A-6702
- Germanischer Lloyd
Cert. #99.342-97
- CE Marked
- Earthquake tested according to ANSI / IEEE
C37.98 – 1987
- Y2K compliant
- US Coast Guard ①
- American Bureau of Shipping ①

① Certificate number pending. Call factory for more information.

General description

Arc monitor with detectors

Introduction

The two units of the Arc Guard System™, arc monitor, and the current sensing unit are each built into a light-alloy enclosure provided with a hinged door.

Communication between the units and between arc monitor and detectors is through optical cables.

Optical fiber cables

The optical fiber cables cannot be cut or joined and they must be run in smooth curves during installation. Optical fiber cables and detectors with optical fiber cables are available in certain standard lengths, see page 2. Greater lengths than these can be quoted on request.

Detectors

Each detector consists of a lens arrangement for collecting light. An optical fiber cable is connected to the lens. The detector monitors a large space angle. The polar diagram should be regarded as three-dimensional since the detector is sensitive to light from all directions, with the exception of a small area behind the detector.

Factory testing has shown that arc light reflected between metallic surfaces is also sufficient to cause tripping. However, we do recommend one detector per each enclosed switchgear compartment.

The detectors are connected to the arc monitor by means of plug-in sleeve terminals.

A maximum of nine detectors can be connected to an arc monitor. If more detectors are required, up to twelve units may be connected in parallel.

Arc monitor

- Available for AC and DC power
- Photodiodes are used for sensing light.
- The two output stages are triacs triggered via a pulse transformer. In this way, detectors and output stage are electrically isolated from other electronic equipment.
- The arc monitor has two separate relay outputs. Each relay has one change-over (Form C) contact function. Relay K1 is used for EXTERNAL TRIP indication and relay K2 is used for POWER ON indication.
- A switch is included for selection of automatic relay resetting (after approximately 200 ms) or manual resetting of relay K1.
- A digital display, visible through the window in the door, is lighted when the triac outputs are activated and shows which detector has caused tripping. The display and relay are

reset using a pushbutton accessible from the outside. The arc monitor can trip even if it is not reset.

- Terminals are provided for connection of the arc monitor's own power supply and for connections to the circuit-breaker trip coil. There are units for plug-in connection of optical fiber cables from the detectors and for communication with any current sensing unit.
- The power consumption of the unit is approximately 6 watts. Energy is stored in the unit for operation up to 200ms should the supply voltage fail, which is sufficient to activate the output even if voltage disappears in conjunction with the short circuit for which the arc monitor operates.

Tripping of several breakers

For tripping several breakers an additional relay is often required. This must be as fast as possible so as not to delay tripping and thus make damage worse.

For DC supply, ABB's relay type RXMS (Cat. No. RK 216 263-...) with 4 ms pickup time is suitable. Where a greater load capacity is required this relay can be connected in parallel with relay type RXMH (Cat. No. RK 223 067-...).

The current to the intermediate relay must be interrupted since the triacs of the arc monitor have no breaking capacity for DC. This can be done by having a pushbutton or time-lag relay break the circuit or by connecting the signal relay contact K1 of the arc monitor in parallel with the triacs. Then activate automatic reset inside arc monitor (DIP-switch S1.2).



Arc monitor

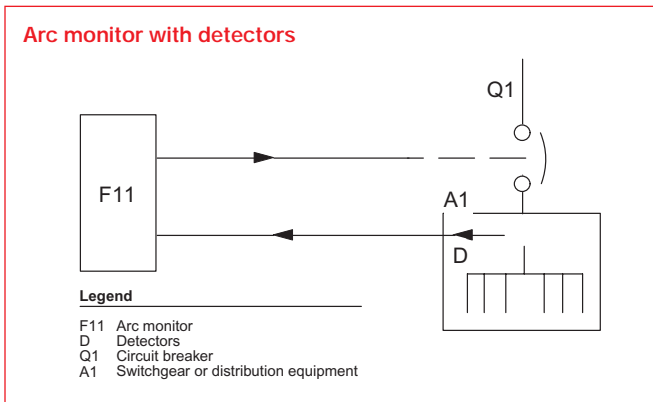
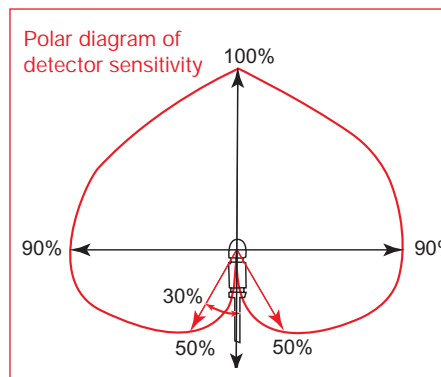

General description

Current sensing unit

Description

- Has terminals for a number of different supply voltages.
- Connects to current transformers located at suitable positions in the busbar system of the installation to be monitored.
- The unit incorporates a selector switch and potentiometer for testing and checking purposes.
- Power consumption is approximately 11 W.
- Optical signal transmission
- If several current sensing units are needed, these can be connected in series using optical cables.
- LEDs indicate when the current exceeds approximately 70% and 100% of the set value.

Connection to current transformers

The unit is to be connected to current transformers with a rated secondary current of 1, 2 or 5 A .

Note that current transformers for relay protection are to be used since these do not saturate as quickly as ordinary current transformers. To minimize the operating time, the current transformers should not saturate until twice the set current has been reached.

The unit can be either 1, 2 or 3-phase connected (to one, two or three current transformers). However, in three-phase systems single-phase connection should be avoided. Even though arcs generally spread to all three phases, valuable time may be lost before the current rises to the trip value if the arc is struck in one of the phases in which the current is not sensed by the unit.

The unit imposes insignificant load on the current transformers, approximately 0.7 VA, so current transformers that are also applied for other purposes can often be used.



Current sensing unit

Current sensing unit

Operates with arc monitor and detectors.

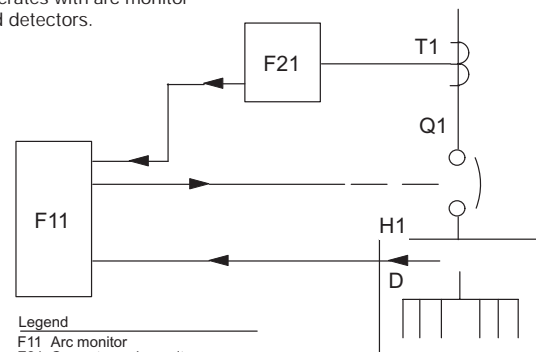

Legend

- F11 Arc monitor
- F21 Current sensing unit
- T1 Current transformers, 3 CTs
- Q1 Circuit breaker
- H1 Switchgear or equipment
- D Detectors

Technical data

Arc monitor

Current sensing unit

Arc monitor

Triac outputs (Static outputs)	disconnectible terminals
Largest load current:	
Continuously	0.7 A
For 200 ms	30 A
Smallest recommended load current	
(temperature $\geq 25^\circ\text{C}$)	DC 45 mA at stated polarity AC 80 mA
(temperature $\geq -25^\circ\text{C}$)	DC 80 mA at stated polarity
Residual current, I_r at 220 V	8 mA 0.5 mA
at DC	The output is connected in parallel with 10 ohm in series with 0.1 μF
For other voltages	$I_r = V \times f \times 0.0006$ (mA) V = voltage f = frequency
Peak withstand voltage	600 V
Power supply voltage	Max. 250 V
Signal relay outputs	
Thermal rated current, I_{th}	5 A
Rated operational current, I_e	
Utilization category per IEC 947-5-1:	
AC 15 $V_e = 250\text{ V}$	1.5 A
DC 13 $V_e = 48\text{ V}$	1.0 A
110 V	0.4 A
220 V	0.2 A
Optical inputs	Quantity
For light detectors	9
From Current Sensing Unit or other Arc Monitor	1
Optical outputs	
To other Arc Monitor	1
Indications	
Operating voltage available	Decimal point on digital display lights up relay K2 energizes.
Upon tripping	Digital display lights up. The display shows which detector was activated (1 – 9). Relay K1 energizes
Control devices/settings:	
<i>External (on door)</i>	
Pushbutton	
- Reset button	Manual resetting
<i>Internal (on the printed circuit board)</i>	
Change-over switch	
- Switching on and off of Current sensing unit	On/Off
- Manual reset of signal relay	On/Off
Trimming potentiometers	
- Sensitivity setting	<i>Normally not to be adjusted</i>
Supply voltage:	See ordering information
Permitted variation	+/-20 % at DC +/-10 % at AC
Internal fuse	0.8 A delayed (5 x 20 mm)
Main fuse	max 10 A fast
Power consumption	6 W
Ambient temperature	-25°C thru +55 °C
Operating times:	
From detection to switched on triac outputs	approx. 1 ms (dependent on light intensity)
From detection to making relay contact	< 10 ms
Current conditions from input to output	< 0.3 ms (with 1 m optical cable)
Degree of protection	NEMA 1 / IP54
Start-up time for power on	< 50 ms at 60V for AGS-AM240 < 50 ms at 24V for AGS-AM48

Current sensing unit

Rated current	
Reconnectible, for connection of external current transformers with secondary rated current	1, 2 or 5 A
Load on the external current transformers	0.2 VA connected for 1 A 0.7 VA connected for 5 A
The current sensing unit withstands a maximum of:	
Continuously	1 x rated current
For 1 second	15 x rated current
Optical outputs:	
To arc monitor/current sensing unit	Quantity: 2
Optical inputs:	
From other current sensing unit	Quantity: 1
Indications:	
• Signal to arc monitor or current sensing unit	Green LED lights up for normal current level (< set overcurrent level)
• Pre-warning	Yellow LED lights up for normal current, switched off at > 70% of set overcurrent level
• Test position	Red LED
Control devices/settings:	
(on the printed circuit board)	
Change-over switch	
Test position	On/Off
Optical input is used or not	On/Off
Trimming potentiometers	
Setting of overcurrent level	0.5 – 4.5 x rated current
Simulation of overcurrent level in test position	
Supply voltage	See ordering information
Permitted variation	+/-20 % at DC +/-10 % at 110-127 VAC +10 % -15 % at 230 VAC
Power consumption	1 W at 24 V 11 W at 220 V
Ambient temperature	-25°C thru + 55 °C
Operating times	
From overcurrent occurring to actuating optical outputs:	
At currents ≥ 2 x set overcurrent level	
3-phase supply.	< 2 ms
1-phase supply.	< 8 ms
Current conditions from optical input to optical outputs	< 0.3 ms
Degree of protection	NEMA 1 / IP54
Detector spectrum	400 – 850 nm, short plastic fiber 400 – 720 nm, long plastic fiber
Interference testing	According to EMC publications IEC1000 and Low Voltage Directive 73/23/EEC, the product is CE-marked.

Technical data

Detector and optical fiber cable



Detector and optical fiber cable

Ambient temperature

Continuous	-25...+70 °C
Short-time	-25...+85 °C

Smallest bending radius

Optical cable of plastic fiber	
after installation	45 mm
while handling	10 mm

Material

PMMA with a sheath of PE and PVC

Terminals

	Terminal	Cross section of connectible cables AWG ① / mm ²
Arc monitor	13, 14, 25 – 30 20 – 23	10 / 4 12 / 2.5
Current sensing unit	1 – 6 10 – 14	10 / 4 12 / 2.5

① AWG estimated.

Circuit diagrams

Arc monitor

Current sensing unit

Arc monitor

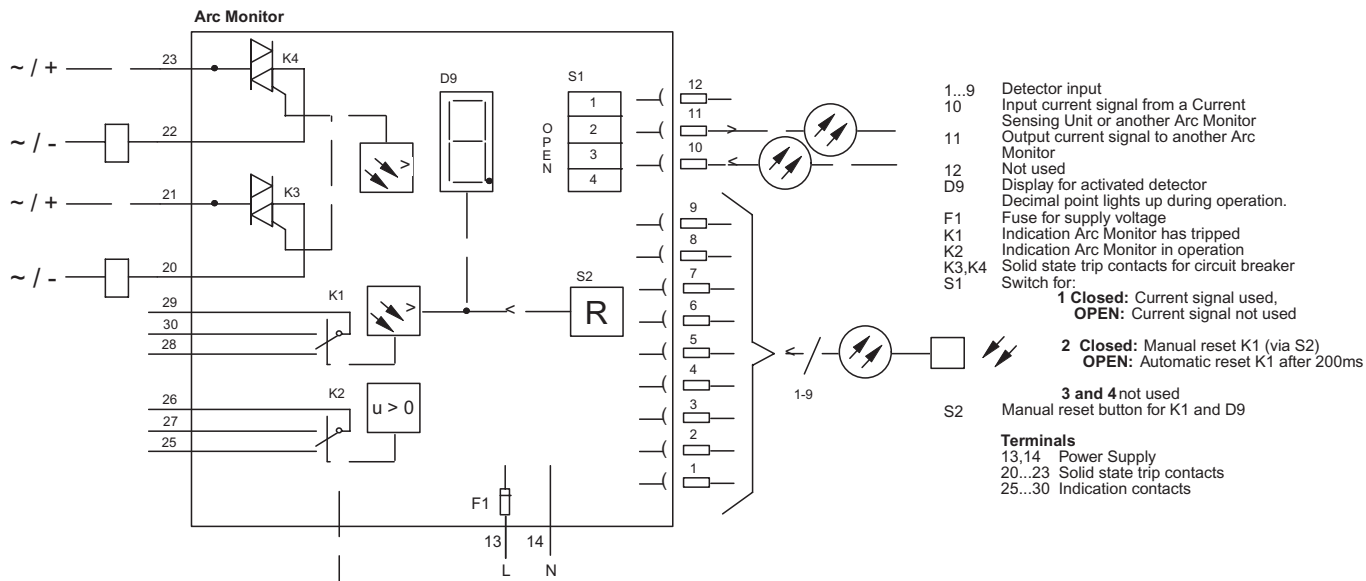

Current sensing unit

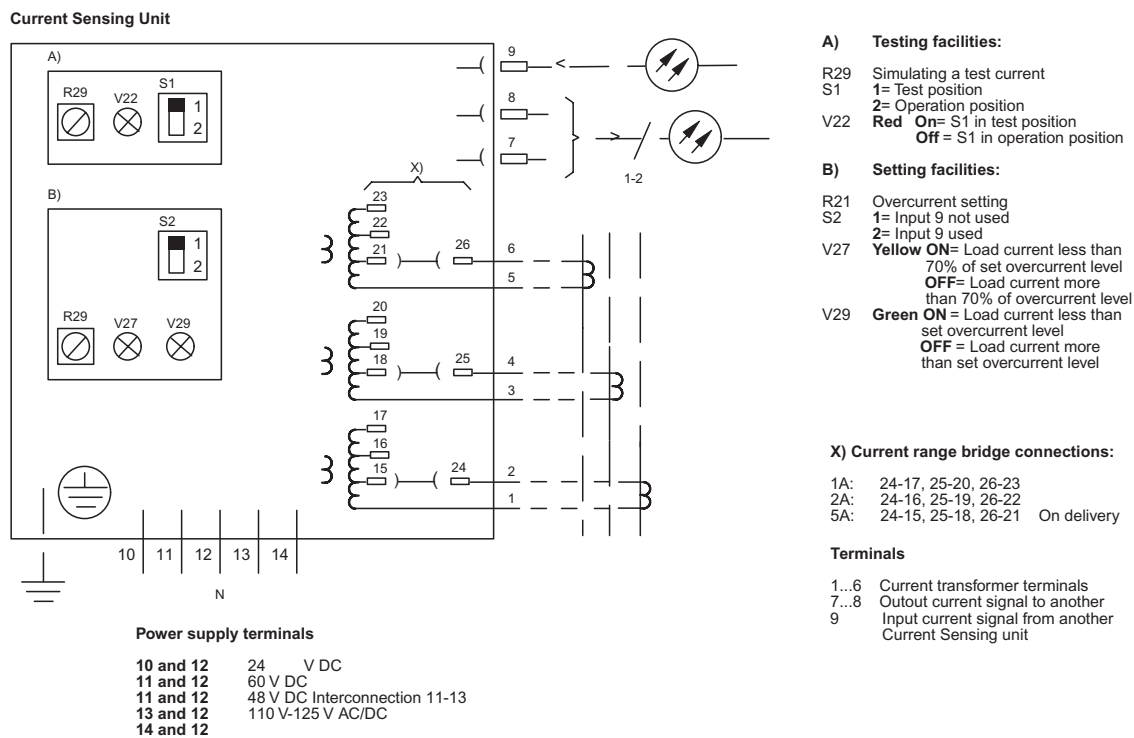

Circuit diagrams

Arc Guard System application

Arc Guard System with two separated circuit-breakers

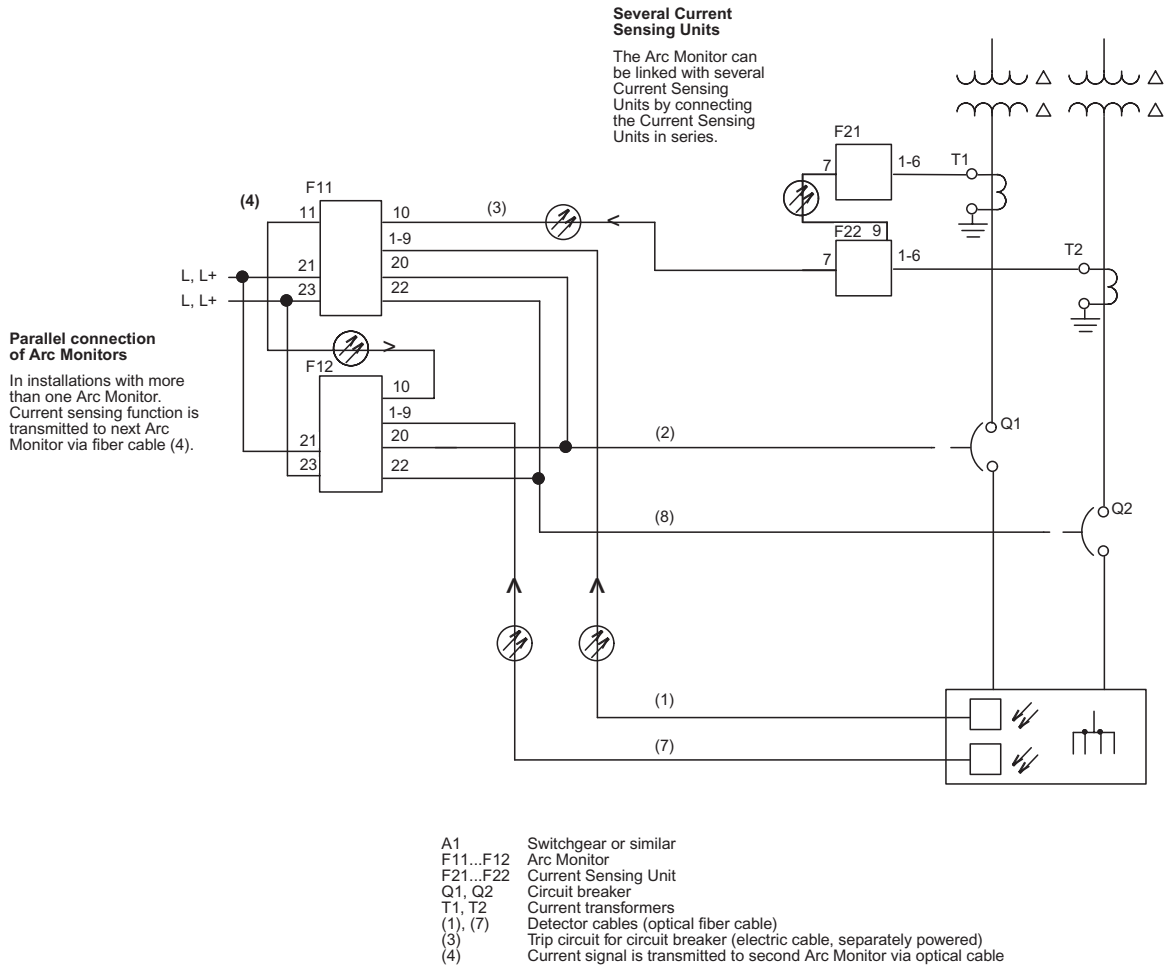

Circuit diagrams

Arc Guard System application

Arc Guard System with current measuring in five incoming feeders

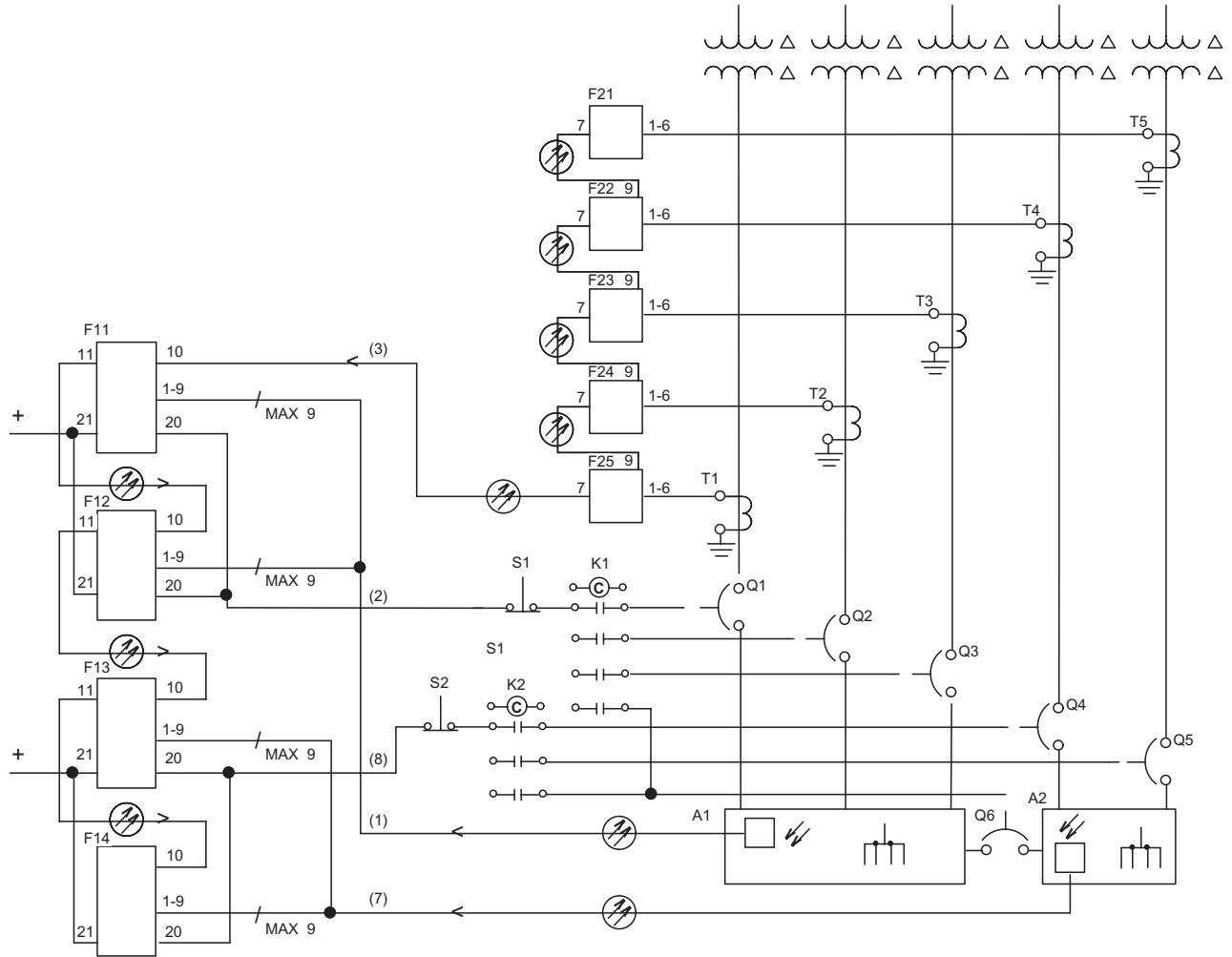

- | | | | |
|-----------|-----------------------|----------|---|
| A1, A2 | Switchgear or similar | Q6 | Bus coupler |
| F11...F14 | Arc monitor | (1), (7) | Detector cables (optical fiber cable) |
| F21...F25 | Current sensing unit | (2), (8) | Trip circuit for circuit breaker (electric cable, separately powered) |
| K1, K2 | Fast tripping relay | (3) | Current signal to Arc monitor (optical fiber cable) |
| T1...T5 | Current transformers | | |
| Q1...Q5 | Circuit breaker | | |

Approximate dimensions Arc Guard System

Arc monitor Current sensing unit

A flange with 6 tapped holes (size 18.6 mm) 4 cable glands (sealing diameter 5.5 – 8.5 mm) and 2 plastic blank plugs are supplied.

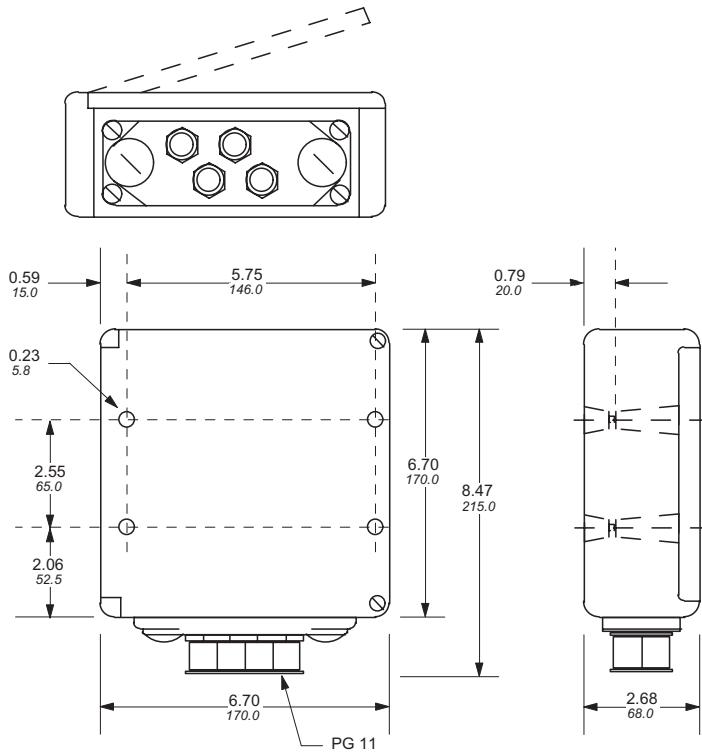

Detector with optical cable

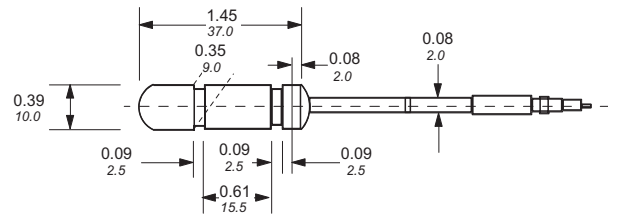

Front panel cut-out

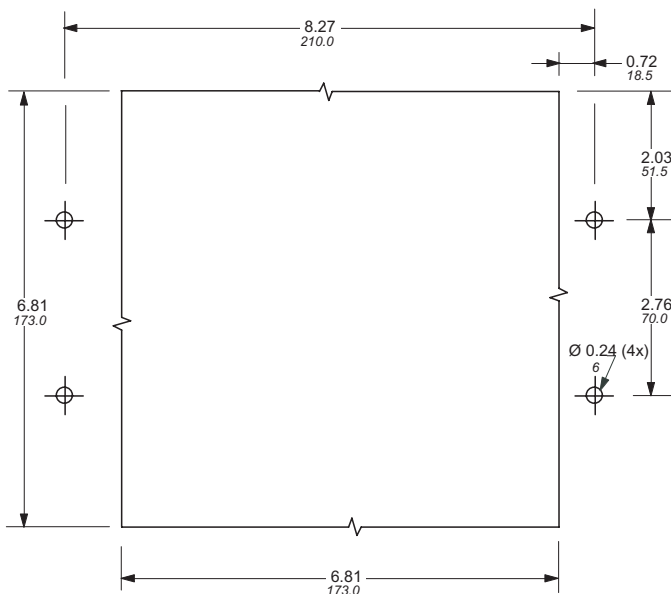

Bracket for fiber optic sensors

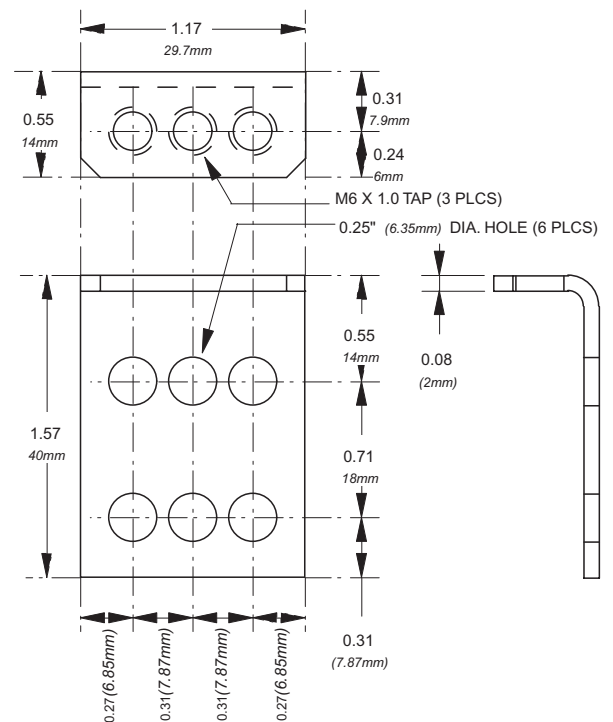



Notes
