

# Electronic Overload relays

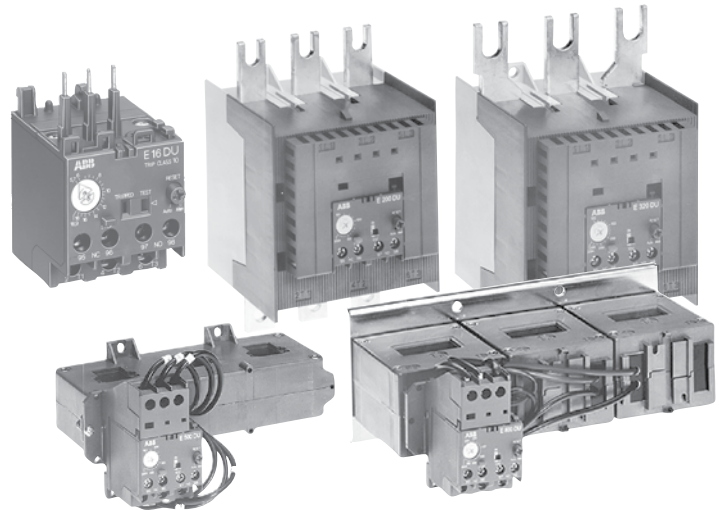

## Electronic overload relays E16DU – E1250DU



### Description

- Available for starter construction with A Line contactors and separate panel mounting
- Designed for close couple mounting
- Separate base mounting available for all overload relays
- E16DU Class 10, 20, & 30, field selectable
- E200DU – E800DU Class 10, 20 & 30, field selectable
- Stop button
- Screwdriver guide holes
- All terminal screws are available from the front
- Single phase and phase unbalance protection
- Isolated alarm circuit (N.O.) contact
- Ambient compensation: -25°C to +70°C (-13°F to +158°F)
- Manual test
- Manual or automatic reset
- Factory calibrated and tested
- Wide adjustment range
- UL File No: E48139
- CSA File No: LR98336

### Tripping classes of the thermal overload relays

Standard classes in IEC 947-4-1 are classes: 10 A, 10, 20, 30. The tripping class indicates according to IEC 947-4-1 the maximum tripping time in seconds under specified conditions of test at 7.2 times the setting current and specifies tripping and non tripping times for 1.5 and 7.2 times the setting current. Mostly used class is 10 A.

### Abstract from IEC 947-4-1

Tripping class	10 A	10	20	30
Max. tripping time at 1.5 x setting current (warm state) (s)	120	240	480	720
Tripping time at 7.2 x setting current (cold state) (s)	2 – 10	4 – 10	6 – 20	9 – 30
At 1.05 x setting current	no tripping			

## Catalog number explanation

2

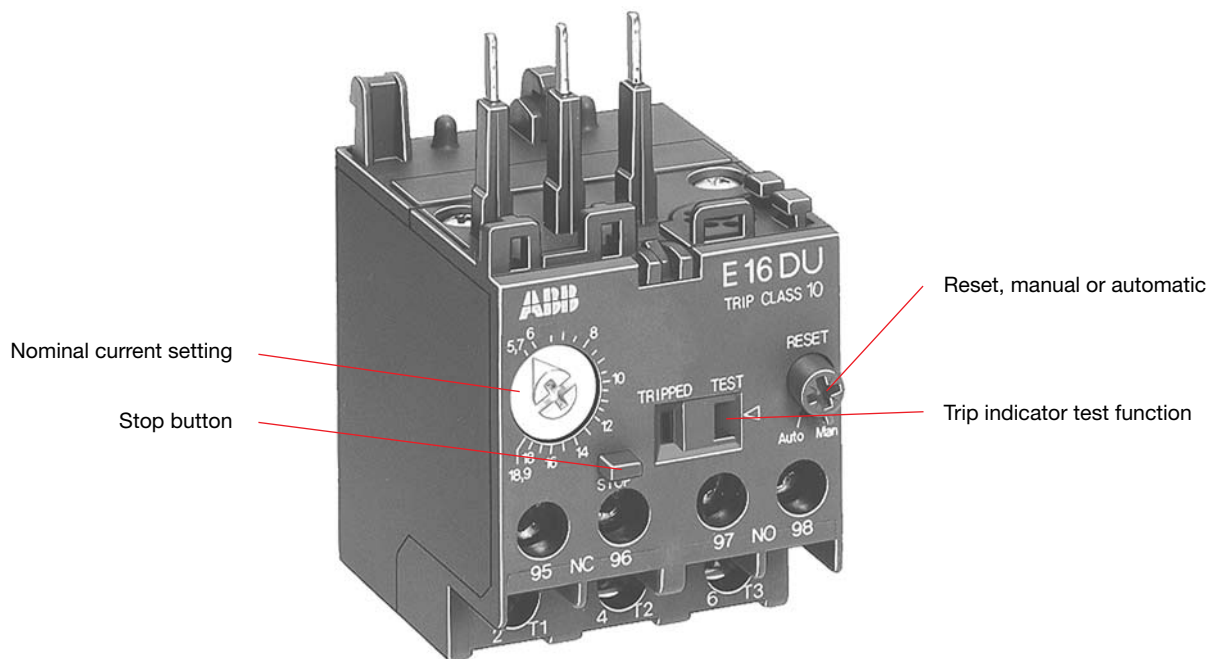

## Catalog number explanation

### E16DU 1.0

**Frame size**

E16DU  
E200DU  
E320DU  
E500DU  
E800DU

**Amp rating**

1.0  
200  
320  
500  
800

## Selection by motor horsepower Starter with electronic overload

Electronic  
Overload  
relays

2

Motor horsepower				Complete starter		Starter components			
3 Phase, 1800 RPM						Contactor		Overload relay	
200V	230V	460V	575V	Catalog number	List Price	Catalog number	List Price	Catalog number	List Price
			1/4	A9S-84B1	<b>\$ 173</b>	A9-30-10-84	<b>\$ 78</b>	E16DU1.0	<b>\$ 96</b>
		1/4, 1/3	1/3			A9-30-10-84		E16DU2.7 (0.9-2.7)	
		1/2	3/4			A9-30-10-84		E16DU6.3 (2.0-6.3)	
	1/2	1	1 1/2			A9-30-10-84		E16DU18.9 (5.7-18.9)	
1/2		1 1/2	2	A9S-84D1	<b>179</b>	A12-30-10-84	<b>84</b>	E45DU30 (9-30)	<b>105</b>
3/4	3/4	2				A16-30-10-84	<b>102</b>		
	1		3	A9S-84E1	<b>347</b>	A26-30-10-84	<b>183</b>	E45DU45 (15-45)	<b>112</b>
1	1 1/2	3	5	A12S-84E1	<b>416</b>	A30-30-10-84	<b>252</b>	E45DU45 (15-45)	
2	2	5	7 1/2	A40S-84B1	<b>468</b>	A40-30-10-84	<b>297</b>	E80DU80 (27-80)	<b>188</b>
3	3	7 1/2	1 0	A50S-84A1	<b>577</b>	A50-30-11-84	<b>330</b>	E140DU140 (50-140)	
5	5	10	15	A63S-84A1	<b>619</b>	A63-30-11-84	<b>372</b>	E200DU200(60-200)	<b>325</b>
	7 1/2	1 5	2 0	A75S-84A1	<b>660</b>	A75-30-11-84	<b>413</b>	E320DU320 (100-320)	
7 1/2	1 0	2 0	2 5	A95S-84A1	<b>770</b>	A95-30-11-84	<b>450</b>	E500DU500 (150-500)	<b>865</b>
10	10			A110S-84A1	<b>800</b>	A110-30-11-84	<b>480</b>	E800DU800 (250-800)	
		25	30	A145S-84E2	<b>1210</b>	A145-30-11-84	<b>825</b>	E1250DU1250 (375-1250)	<b>2790</b>
1 0	15	30	40	A185S-84E2	<b>1675</b>	A185-30-11-84	<b>1290</b>		
15	20	40	50	A210S-84E3	<b>2135</b>	A210-30-11-84	<b>1635</b>		<b>775</b>
20		50	60	A260S-84E3	<b>2740</b>	A260-30-11-84	<b>1850</b>		
25	30	60	75	A300S-84E3	<b>2890</b>	A300-30-11-84	<b>1875</b>		<b>950</b>
3 0				A400S-70E5	<b>4125</b>	AF400-30-11-70	<b>3120</b>		
	40	75	100	A460S-70E5	<b>5700</b>	AF460-30-11-70	<b>4425</b>		<b>950</b>
4.0	50	100	125	A580S-70E8	<b>8346</b>	AF580-30-11-70	<b>6900</b>		
5 0	60	125	150	A750S70E8		AF750-30-11-70	<b>7200</b>		
60	75	150	200	A1350S-70E12	<b>11,578</b>	AF1350-30-11-70	<b>8490</b>		<b>2790</b>
75	100	200	250	A1650S-70E12	<b>13,450</b>	AF1650-30-11-70	<b>10,230</b>		
100		250	300						
12 5	5/6	35 0	40 0						
150	200	400	500						
200	250	500	600						
250	300	600	700						
	400	800	900						
	450	900	1000						

## E16DU – E1250DU for contactors and mini contactors

2

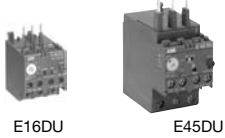

E16DU

E45DU



E80DU

E140DU

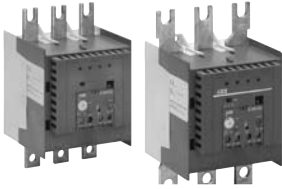

E200DU

E320DU

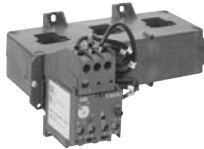

E500DU

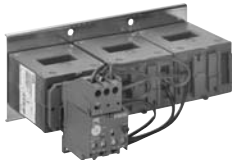

E800DU

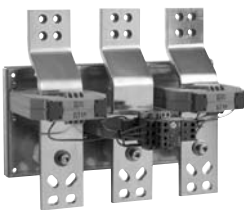

E1250DU



Universal Motor Controller

Catalog number	Setting range	Trip class	List price	Contactor	Suffix code
<b>Trip Class, Selectable 10, 20, 30</b>					
E16DU0.32	0.1-0.32A	10, 20, 30	<b>\$ 96</b>	B...6-B...7 / A...9...A...16...	A1
E16DU1.0	0.3-1.0A	10, 20, 30		B...6-B...7 / A...9...A...16...	B1
E16DU2.7	0.9-2.7A	10, 20, 30		B...6-B...7 / A...9...A...16...	C1
E16DU6.3	2.0-6.3A	10, 20, 30		B...6-B...7 / A...9...A...16...	D1
E16DU18.9	5.7-18.9A	10, 20, 30		B...6-B...7 / A...9...A...16...	E1

### Trip Class selectable, 10, 20, 30

E45DU30	9-30A	10, 20, 30	<b>105</b>	A...26 ... A...40	E1
E45DU45	15-45A	10, 20, 30	<b>112</b>	A...26 ... A...40	E2
E80DU80	27-80A	10, 20, 30	<b>188</b>	A...50 ... A...75	E1
E140DU140	50-140A	10, 20, 30	<b>261</b>	A...95 ... A...110	E1
E200DU200	65-200A	10, 20, 30	<b>325</b>	A...145 ... A...185	E2
E320DU320	105-320A	10, 20, 30	<b>775</b>	A...210 ... A...300	E3
E500DU500	170-500A	10, 20, 30	<b>865</b>	AF...400 ... AF...460	E5
E800DU800	270-800A	10, 20, 30	<b>950</b>	AF...580 ... AF...750	E8
E1250DU1250	375-1250	10, 20, 30	<b>2970</b>	AF...1350 ... AF...1630	E12

### Universal motor controller

Universal motor controller with thermal overload protection 0.24 - 63 A in a single device type. Bushing-type transformer, cable cross section 25mm<sup>2</sup> (max. diameter including insulation - 11mm). Integrated motor control functions: Direct starting, reverse starting, star-delta starting, servo-drive functions. Diagnostic functions: Overload phase failure, trip categories, 5, 10, 20, 30. Integrated storage of parameters and motor data. 6 digital inputs, 3 relay outputs. Fieldbus-independent interface for connection to FBP fieldbus connectors, interface to operating panel ACS100-PAN.

Description	Contactor	Setting range	Trip class	Catalog number	List price
UMC22-FBP.0	A9 - AF1650	0.63 - 63 A	5, 10, 20, 30	1SAJ510000R0400	<b>\$ 689.50</b>



DB16E



Operating panel

## Mounting kits

for direct mounting on contactors AF400 – AF750

For overload relays	On contactor	Catalog number	List price
E500DU	AF400 – AF460 AF400 – AF460 w/reversing kits	DT500/AF460S DT500/AF460L	<b>\$ 395</b>
E800DU	AF580 – AF750 AF580 – AF750 w/reversing kits	DT800/AF750S DT800/AF750L	<b>415</b>

## Separate mounting kits

For overload relays	Catalog number	List price
E16DU	DB16E	<b>\$ 15</b>
E45DU	DB45E	<b>39</b>
E80DU	DB80E	<b>48</b>
E110DU	DB140E	<b>70</b>

## Lug kits

Wire range	Electronic overload	Catalog number	List price
6 – 250 MCM	E200DU200	ATK185	<b>\$ 45</b>
4 – 400 MCM	E320DU320	ATK300	<b>68</b>
(2) 4 – 500 MCM	E320DU320	ATK300/2	<b>110</b>
(2) 2/0 – 500 MCM	E500DU500	ATK580/2HK	<b>160</b>
(3) 2/0 – 500 MCM	E800DU800	ATK750/3HK	<b>235</b>
(4) 1/0 – 750 MCM	E12150DU1250	ATK1350/4HK	<b>275</b>

## Terminal shrouds

For overload relays	Catalog number	List price
E200DU E320DU	LT200E LT320E	<b>\$ 41</b>
E500DU E800DU	LT500E LT800E	<b>52</b> <b>56</b>

## Accessories for Universal Motor Controller UMC22-FBP

Operating, diagnostics and parameter setting panel for Universal Motor Controller UMC22-FBP. Setting of motor and bus parameters.

Type	Designation	Usage with	Catalog number	List price
ACS100-PAN	Operating panel	UMC22-FBP	1SAJ510001R0001	<b>\$ 100.60</b>

## Accessories for operating panel ACS100-PAN

Extension cable 3 m and door mounting set IP65 (front side) for ACS100-PAN operating panel.

Type	Designation	Usage with	Catalog number	List price
ACS100-CAB.300	Extension cable 3m with door mounting set	ACS100-PAN	1SAJ510002R0001	<b>\$ 191.00</b>
ACS100-CAB.070	Extension cable 3m with front mounting set	ACS100-PAN	1SAJ510003R0001	<b>168.00</b>

## Current transformers for use with the Universal Controller UMC22-FBP

Secondary-linear transformer, 3-phase with terminal block, intended for conductors Cu 2.5mm<sup>2</sup>.

Type	Designation	Current range recommended	Catalog number	List price
KORC 4L 185 R/4	Current transformer	60 - 185 A	1SCA022193R7830	<b>\$ 600.00</b>
KORC 4L 310 R/4	Current transformer	180 - 310 A	1SCA022181R0760	<b>650.00</b>
KORC 5L 500 R/4	Current transformer	300 - 500 A	1SCA022208R1010	<b>700.00</b>
KORC 5L 850 R/4	Current transformer	500 - 850 A	1SCA022208R1440	<b>750.00</b>

## Connection kit for use with the KORC-current transformers

Connection kit for applications with KORC-current transformers with A-series contactors

Type	Designation	Appropriate for contactor type	Catalog number	List price
DT 450 / A185	Connection kit	AF145 - AF185	1SAZ501901R1001	<b>\$ 225.00</b>
DT 450 / A300	Connection kit	AF260 - AF300	1SAZ501902R1001	<b>225.00</b>
DT 500 / AF460L	Connection kit ①	AF400 - AF460	1SAX701902R1001	<b>395.00</b>
DT 800 / AF750L	Connection kit ①	AF580 - AF750	1SAX801902R1001	<b>415.00</b>

① Connection kit for Star-Delta-Starter

## General technical data

Type	E16DU	E45DU30	E45DU45	E80DU80	E140DU140
<b>Standards:</b>	IEC/EN 60 947-4-1 / IEC/EN 60 947-5-1				
<b>Approvals and certificates</b>	UL, CSA				
<b>Rated insulation voltage <math>U_i</math></b> V	600			600	
<b>Rated operating voltage <math>U_e</math></b> V	600			600	
<b>Impulse withstand voltage <math>U_{imp}</math></b> kV	6				
<b>Permissible ambient temperature</b>					
– Storage °C	– 25 to + 70				
– Operation °C	– 25 to + 70				
<b>Climatic resistance according to</b>	on request				
<b>Mounting position</b>					
<b>Resistance to shock</b> Shock duration ms multiple of g	on request <sup>(1)</sup>				
<b>Resistance to vibrations to EN 61373</b>	on request				
<b>Mounting</b> – by screws: – onto contactor:	separate mounting with Kit for single set up by screws 4xM5 or direct mounting onto contactor - no kit necessary				
<b>Connection terminals and attachment type</b>					
<b>Main contactors (load side)</b>					
• Screw terminal – with self-disengaging clamping piece	M5/2,3 ... 2,6 Nm			M8/6 ... 6,5 Nm	
• Connection cross-sections – single-core or stranded mm <sup>2</sup>	1 x 2,5 ... 16 2 x 2,5 ... 16			1 x 10 ... 95 2 x 6 ... 35	
– flexible with wire end ferrule mm <sup>2</sup>	1 x 2,5 ... 10 2 x 2,5 ... 10			1 x 10 ... 70 2 x 6 ... 35	
<b>Connection to aux.-contacts terminals</b>					
• Screw terminal – with self-disengaging clamping piece	M3,5/0,8 ... 1,0 Nm				
• Connection cross-sections – single-core or stranded mm <sup>2</sup>	1 x 1 ... 4 2 x 1 ... 4				
– flexible with wire end ferrule mm <sup>2</sup>	1 x 0,75 ... 2,5 2 x 0,75 ... 2,5				
<b>Protection degree to IEC/EN 60 947-1</b>	IP 20			IP 10	
	All terminals are safe from finger-touch and safe from touch by the back of the hand to EN 50274				

## Technical data of the conducting paths

Type	E16DU	E45DU30	E45DU45	E80DU80	E140DU140
<b>Number of conducting paths</b>	3				
<b>Setting ranges</b> A ... A	0,1 ... 18,9	9 ... 30	15 ... 45	27 ... 80	50 ... 140
<b>Tripping classes to IEC/EN 60 947-4-1</b>	10 or selectable 10, 20, 30				
<b>Frequency range</b> Hz	50 and 60 (only for a.c. operating 3 phase)				
<b>Switching frequency</b> without early tripping	80 ops./h with 40% if the making current does not exceed 6 x in and starting time does not exceed 1s.				

## Load rating of auxiliary contacts

Contact	NC (95-96)	NO (97-98)
<b>Rated operating voltage <math>U_e</math></b> V	600	600
<b>Rated thermal continuous current</b> A	6	6
<b>Rated operating current <math>I_e</math></b>		
at AC-15 230 V A	3	3
at AC-15 400 V A	1,1	1,1
at AC-15 500 V A	0,7	0,7
at DC-13 24 V A	1,5	1,5
at DC-13 60 V A	0,5	0,5
at DC-13 110 V A	0,4	0,4
at DC-13 220 V A	0,2	0,2
<b>Short-circuit protection fuse gG</b> A	6	6
<b>STOTZ safety circuit-breaker: S271, S281</b>	(2)	(2)

(1) on request

# E200/320/500/800/1250DU

## Technical data

Electronic  
Overload  
relays

2

### General technical data

Type	E200DU	E320DU	E500DU	E800DU	E1250DU
<b>Standards:</b>	IEC/EN 60 947-4-1 / IEC/EN 60 947-5-1				
<b>Approvals and certificates</b>	UL, CSA				
<b>Rated insulation voltage <math>U_i</math></b>	<b>V</b>	600			
<b>Rated operating voltage <math>U_o</math></b>	<b>V</b>	600			
<b>Impulse withstand voltage <math>U_{imp}</math></b>	<b>kV</b>	6			
<b>Permissible ambient temperature</b>					
– Storage	°C	– 25 to + 70			
– Operation	°C	– 25 to + 70			
<b>Climatic resistance according to</b>	IEC 68-2-1, IEC 68-2-2 IEC 68-2-14, IEC 68-2-30		IEC 68-2-1, IEC 68-2-2, IEC 68-2-30		
<b>Mounting position</b>	any				
<b>Resistance to shock</b>	Shock duration ms multiple of g	30 5			
<b>Resistance to vibrations to EN 61373</b>	category 1 class B				
<b>Mounting</b>	– by screws: 4 x M5	– by screws: 4 x M5	– by screws: 4 x M5 with DT ... ring kit	– by screws: 4 x M6 with DT ... mounting kit	– by screws: 4 x M6 with DT ... mounting kit
	direct mounting to contactor				
<b>Connection terminals and attachment type</b>					
<b>Main contactors</b> (load side)					
• Screw terminals – with busbar or cable lugs	M8	M10	M10 (rail order separately)	M12 (rail order separately)	M12
<b>Connection terminals and attachment type</b>					
<b>Auxiliary contacts</b>					
• Screw terminal – with self-disengaging clamping piece – tightening torque	<b>Nm</b>		M3,5 1,0		
• Connection cross-sections					
– single-core or stranded	<b>mm<sup>2</sup></b>				
– flexible with wire end ferrule	<b>mm<sup>2</sup></b>		2 x 0,75 ... 4 2 x 0,75 ... 2,5		
<b>Protection degree to IEC/EN 60 947-1</b>	All terminals are safe from finger-touch and safe from touch by the back of the hand to EN 50274				IP 00

### Technical data of the conducting paths

Type	E200DU	E320DU	E500DU	E800DU	E1250DU
<b>Number of conducting paths</b>	3				
<b>Setting ranges</b>	<b>A ... A</b>	60 ... 200	100 ... 320	150 ... 500	250 ... 800 375 ... 1250
<b>Tripping classes to IEC/EN 60 947-4-1</b>	10, 20, 30 selectable				
<b>Frequency range</b>	Hz	50 and 60 (only for a.c. operating 3 phase)			
<b>Switching frequency</b> without early tripping		80 ops./h with 40% if the making current does not exceed 6 x in and starting time does not exceed 1s.			

### Load rating of auxiliary contacts

Type	E200DU, E320DU, E500DU, E800DU, E1250DU			
Contact	NC (95-96)		NO (97-98)	
<b>Rated operating voltage <math>U_o</math></b>	<b>V</b>	600		600
<b>Rated thermal continuous current</b>	<b>A</b>	6		6
<b>Rated operating current <math>I_o</math></b>				
at AC-15 230 V	<b>A</b>	3		3
at AC-15 400 V	<b>A</b>	1,1		1,1
at AC-15 500 V	<b>A</b>	0,7		0,7
at DC-13 24 V	<b>A</b>	1,5		1,5
at DC-13 60 V	<b>A</b>	0,5		0,5
at DC-13 110 V	<b>A</b>	0,4		0,4
at DC-13 220 V	<b>A</b>	0,2		0,2
<b>Short-circuit protection fuse</b>	gG	6		6
<b>STOTZ safety circuit-breaker: S271, S281</b>		(1)		(1)

### General technical data

Type	UMC22-FBP	
Rated operating voltage $U_e$ (three-phase system) <b>V AC/Hz</b>	max. 690/50	
Rated operating current range <b>A</b>	0.24 ... 63	
Trip classes	5, 10, 20, 30	
Short-circuit-protection	separate fuses on power line side	
Supply voltage <b>V DC</b>	19.2 ... 31.2, including ripple	
Supply current <b>mA</b>	max. 130 (at 18 ... 30 V DC)	
Total device power dissipation <b>W</b>	max. 3.1 (at 24 V DC)	
LEDs on front	LED 1, green: device ready for operation LED 2, yellow: motor current > 33 % of $I_s$ LED 3, red: fault (trip, device fault, etc.)	
Mechanical relay contact lifetime	500 000 switching cycles	
Electrical lifetime	250 V AC / 0.5 A	100 000 switching cycles
	250 V AC / 1.5 A	50 000 switching cycles
Terminal conductor cross section <b>mm<sup>2</sup></b>	max. 2.5, max. 2 x 1.5	
Current transformer bushing holes	11 mm Ø (25 mm <sup>4</sup> )	
Internal clearance and creepage distances <b>mm</b>	> 5.5 (safety insulation up to 250 V AC)	
Mounting	on DIN rail (EN 50022-35) or wall mounting with 4 screws M4	
Dimensions (W x H x D) <b>mm</b>	70 x 105 x 110 (incl. FieldBusPlug and Control Panel)	
Net weight <b>kg</b>	0.39 (current transf. + control unit)	
Degree of protection	IP 20	
Storage temperature range <b>°C</b>	-25...+70	
Operating temperature range <b>°C</b>	0...+55	
Technical description Order Code	2CDC 135 004 D02xx	
FieldBusPlug connection	see FBP catalogue	

### Digital inputs

Number of digital inputs	6 (DI0 ... DI5)
Power supply for digital inputs	18 ... 30V, 70 mA
1-Signal (range including ripple)	+13 V ... +31,2 V
0-Signal (range including ripple)	-31,2 V ... +13 V
Input current per channel	(24 V DC) typ. 6.0 mA
Input resistor to 0 V	3.9 kOhm
Line length unshielded	max. 600 m
Line length shielded	max. 1000 m

### Digital outputs

Number of digital relay outputs	3 (DO0...DO2)
Grouping of contacts	3 contacts with 1 common
Switching capacity per relay contact	
AC15:	120 V AC, max. 3 A 240 V AC, max. 1.5 A
DC13:	24 V DC, max. 0.1 A 125 V DC, max. 0.22 A 250 V DC, max. 0.11 A
max. load for all contacts	4 A (terminal 5 or 6)
min load for switching signals	12 V, 1 W or 1 VA
PTC Input - direct connection of PTC sensors from the motor	
Conductor holes through the current transformers max. 25 mm <sup>2</sup> (max. diameter incl. insulation 11 mm)	

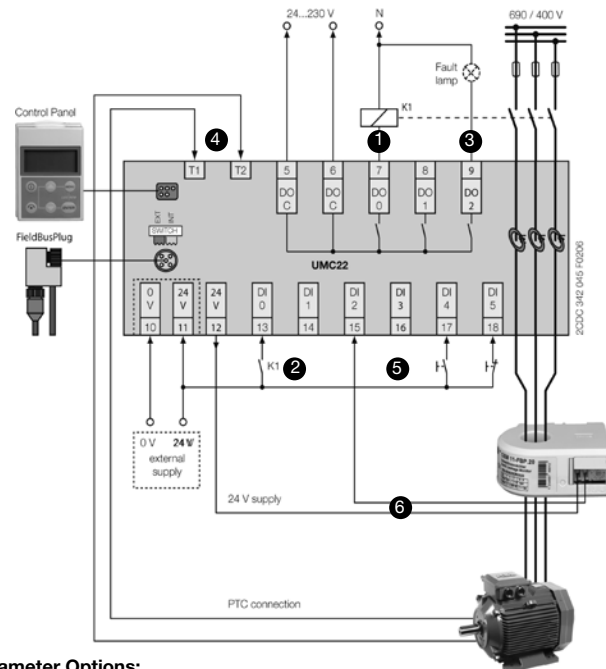

#### Parameter Options:

- 1 = Control function
- 2 = check back via aux.-contact
- 3 = Fault output, e.g. to lamp
- 4 = PTC Input
- 5 = digital inputs for control signals
- 6 = Connections for earth fault monitor

# Technical data

## Terms and technical definitions

### Altitude

Characterizes the place of use. It is expressed in meters above sea level.

### Circuits

- **Auxiliary circuit** – all the conductive parts of a contactor designed to be inserted in a different circuit from the main circuit and the contactor control circuits.
- **Control circuit** – all the conductive parts of a contactor (other than the main circuit and the auxiliary circuit) used to control the contactor's closing operation or opening operation or both.
- **Main circuit** – all the conductive parts of a contactor designed to be inserted in the circuit that it controls.

### Insulation Class according to NFC 20 040 and VDE 0110

Characterizes adaptation of the devices to ambient temperature and operating conditions. For given clearances and creepage distances, a device will have different insulating voltages depending on insulation classes A, B, C & D. Class C corresponds to most industrial applications. The devices in this catalog belong to Class C.

### Coordination of equipment protections during a short circuit

This is the addition upstream of the contactor and thermal overload relay of a short circuit (SCPD) protection device such as a circuit breaker, a fuse with a high breaking capacity or other fuses.

IEC publication 947-4-1 defines coordination Types 1 & 2:

- **Type 1** – Coordination requires that, in the event of a short circuit, the contactor or starter does not endanger persons or installations and will not be able to operate without being repaired or parts being replaced.
- **Type 2** – Coordination requires that, in short circuit conditions, the contactor or starter does not endanger persons or installations and will be able to operate afterwards. The risk of contacts being welded is acceptable. In this case, the manufacturer must stipulate the measures to be taken with respect to maintenance of the equipment.

### Rated operational current $I_e$

Current rated by the manufacturer. It is mainly based on the rated operational voltage  $U_e$ , the rated frequency, the utilization category, the rated duty and the type of protective enclosure, if necessary.

### Conventional free air thermal current $I_{th}$

Current that the contactor can withstand in free air for a duty time of 8 hours without the temperature rise of its various parts exceeding the maximum values given by the standard.

### Cycle time

Cycle time is the sum of the current flow time and the no-current time for given cycle.

### Electrical durability

Number of on-load operations that the contactor is able to carry out; it depends on the utilization category.

### Mechanical durability

Number of no-current operations that a contactor is able to carry out.

### Load factor

Ratio of the on-load operating time to the total cycle time x 100.

### Switching frequency

Number of switching cycles per hour.

# Approximate dimensions E16DU – E140DU

2

## E16DU

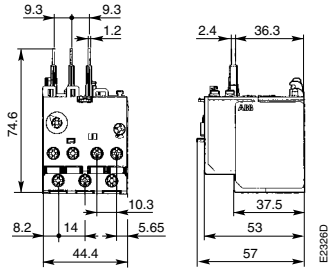

## E16DU + DB16E

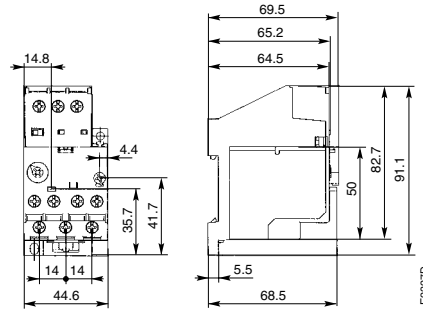

## E45DU

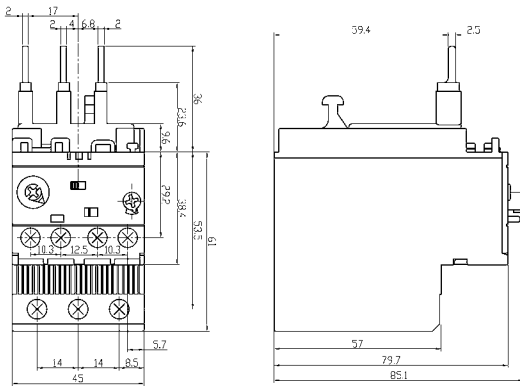

## E80DU

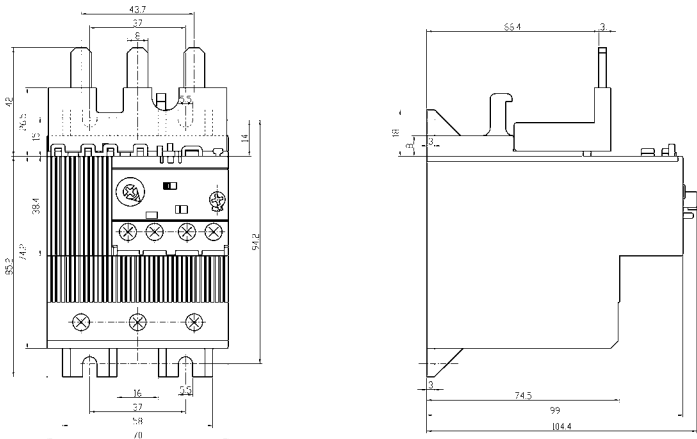

## E140DU

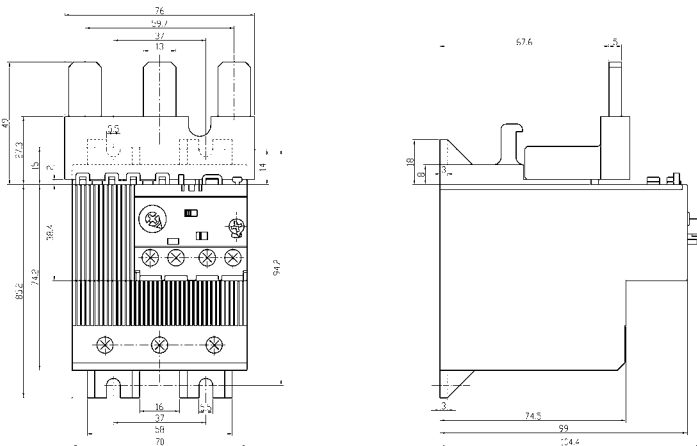

# Approximate dimensions E200DU – E320DU

## E200DU

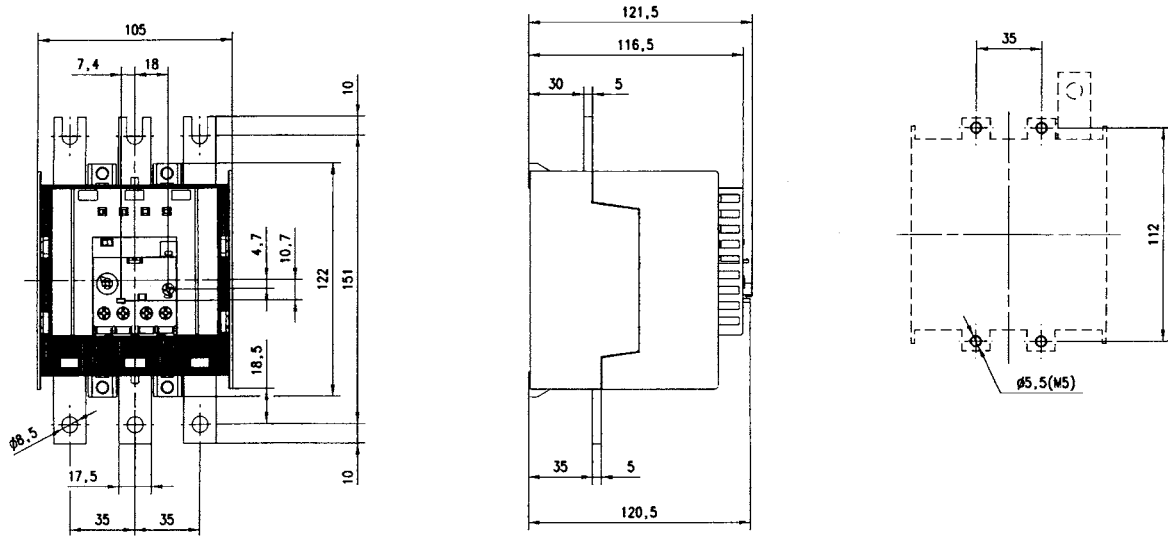

## E320DU

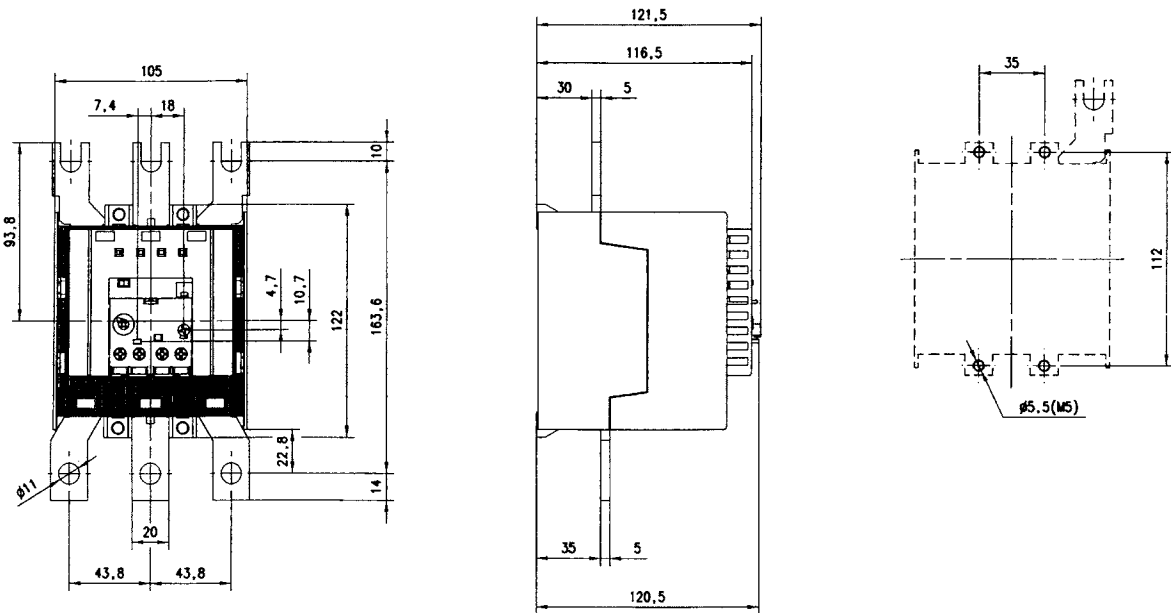

Approximate dimensions  
E500DU – E800DU  
E1250DU + AF1350 / AF1650

2

E500DU

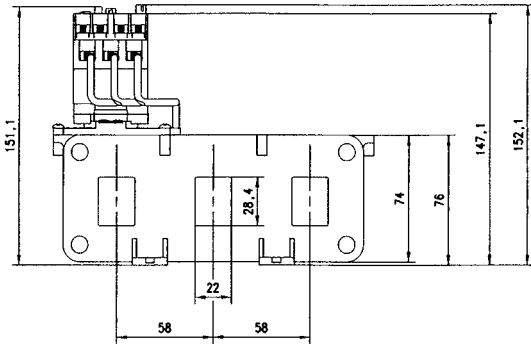

E800DU

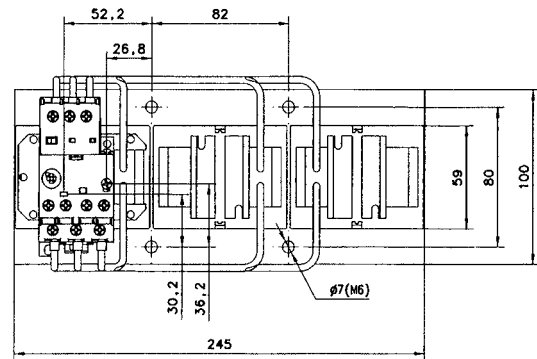
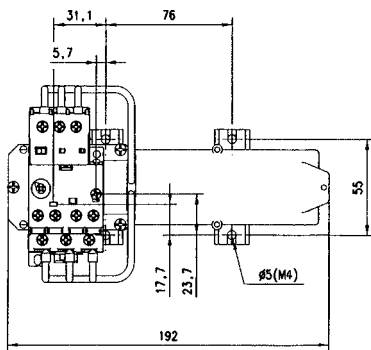
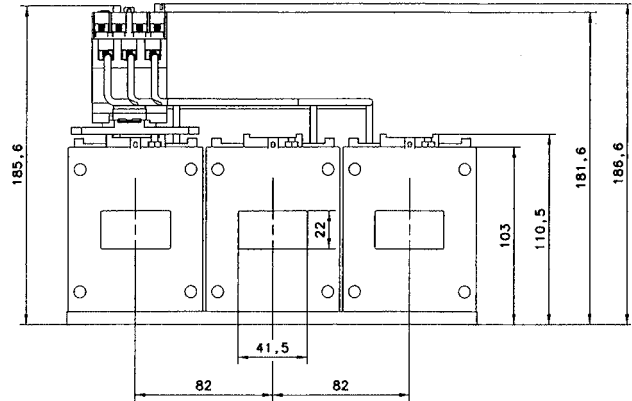

AF1350 / AF1650 + E1250DU

Drilling plan

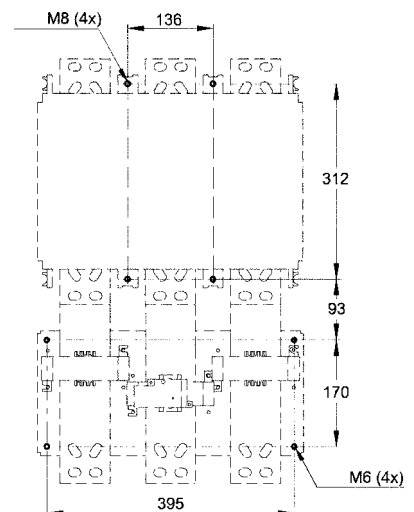
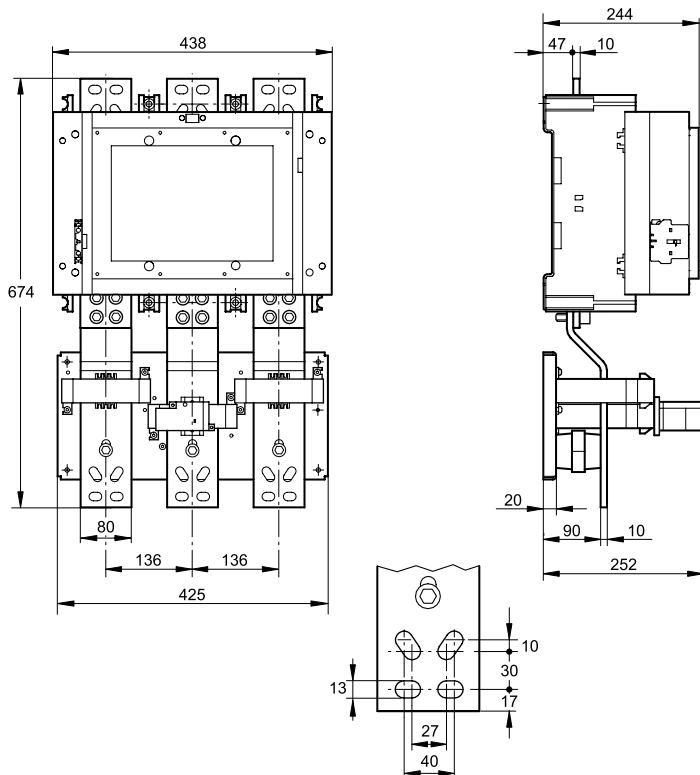

(dimensions in mm)

# Electronic overload relays

## Dimensions

### Starter combination with contactor and terminal shroud

**AF400 / AF460 + E500DU + DT500 / AF460S + LT500**

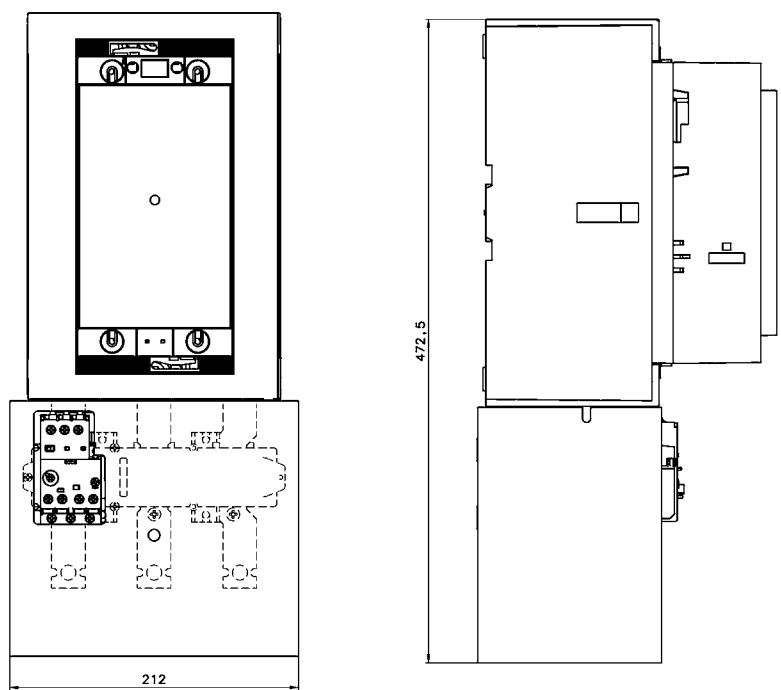

**Drilling plan**

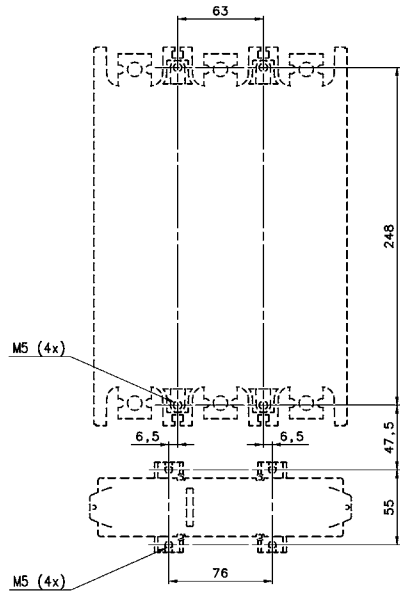

**AF400 / AF460 + E500DU + DT500 / AF460L**

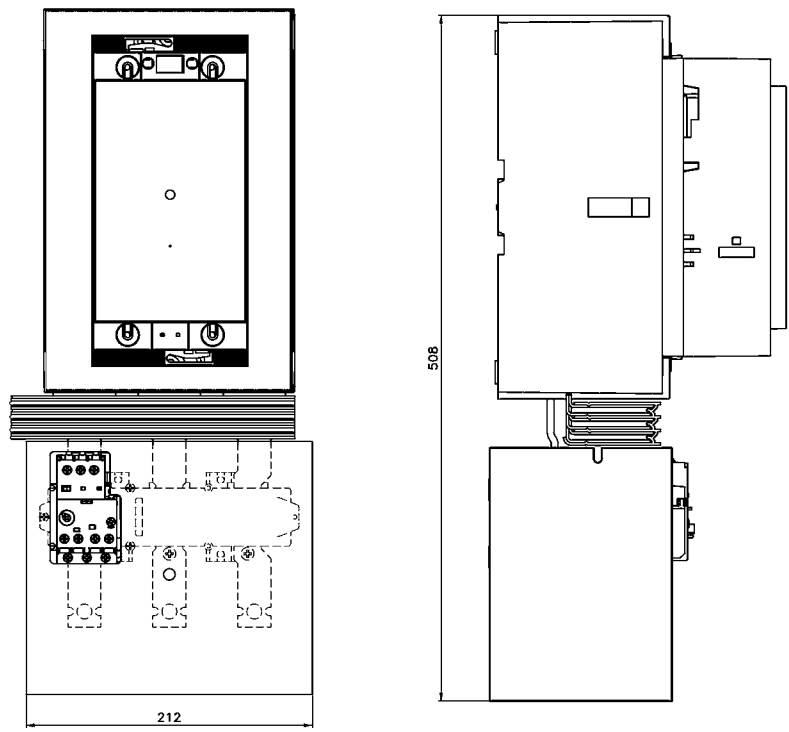

**Drilling plan**

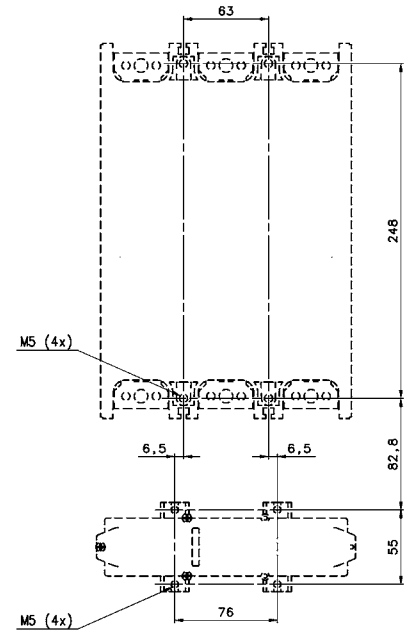

(dimensions in mm)

## Electronic overload relays

### Dimensions

### Starter combination with contactor and terminal shroud

2

AF580 / AF750 + E800DU + DT800 / AF750S + LT800

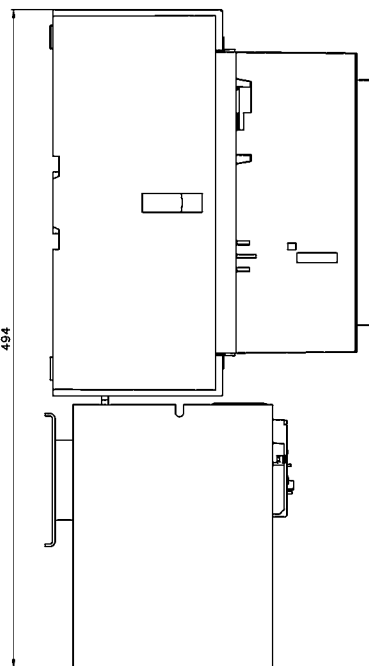
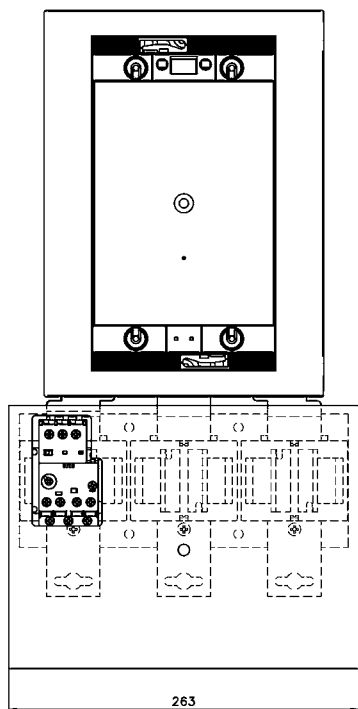

### Drilling plan

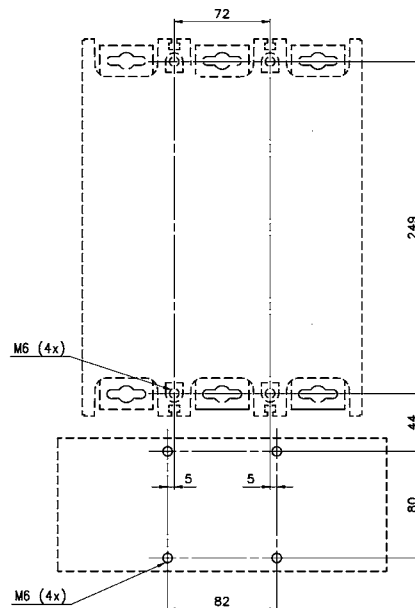

AF580 / AF750 + E800DU + DT800 / AF750L

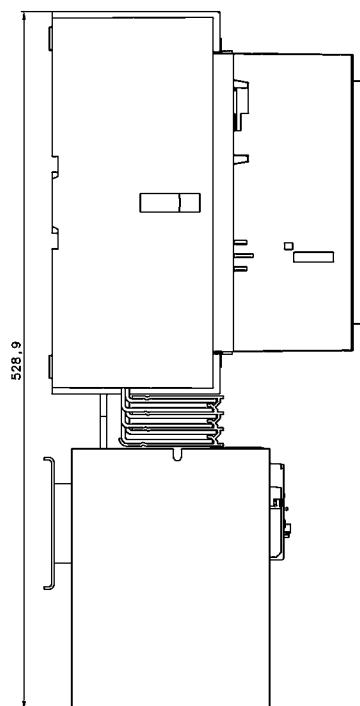
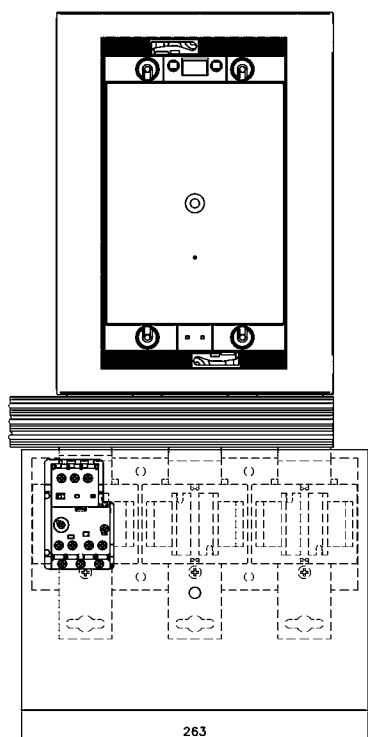

### Drilling plan

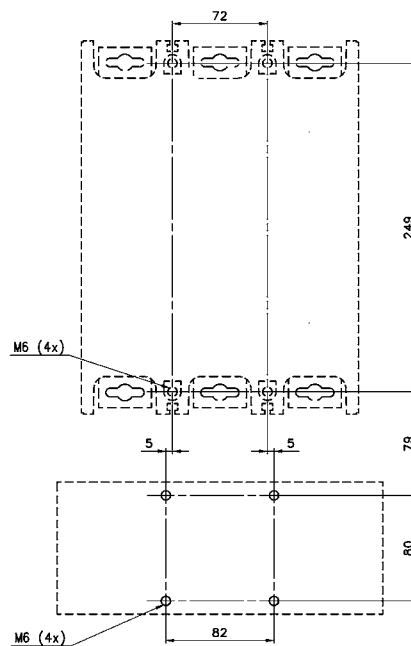

(dimensions in mm)