

Extract from NEC® Separate overcurrent protection

Extract from 2002 NEC® Code Requirements

460-8. Conductors.

(A) Ampacity. The ampacity of capacitor circuit conductors shall not be less than 135 percent of the rated current of the capacitor. The ampacity of conductors that connect a capacitor to the terminals of a motor or to motor circuit conductors shall not be less than one third the ampacity of the motor circuit conductors and in no case less than 135 percent of the rated current of the capacitor.

(B) Overcurrent Protection. An overcurrent device shall be provided in each ungrounded conductor for each capacitor bank. The rating or setting of the overcurrent device shall be as low as practicable.

Exception: A separate overcurrent device shall not be required for a capacitor connected on the load side of a motor overload protective device.

(C) Disconnecting Means. A disconnecting means shall be provided in each ungrounded conductor for each capacitor bank and shall meet the following requirements.

- (1) The disconnecting means shall open all ungrounded conductors simultaneously.
- (2) The disconnecting means shall be permitted to disconnect the capacitor from the line as a regular operating procedure.
- (3) The rating of the disconnecting means shall not be less than 135 percent of the rated current of the capacitor.

Exception: A separate disconnecting means shall not be required where a capacitor is connected on the load side of a motor controller.

460-9. Rating or Setting of Motor Overload Device. Where a motor installation includes a capacitor connected on the load side of the motor overload device, the rating or setting of the motor overload device shall be based on the improved power factor of the motor circuit.

The effect of the capacitor shall be disregarded in determining the motor circuit conductor rating in accordance with Section 430-22.

NOTE: *National Electric Code® and NEC® are registered trademarks of the National Fire Protection Association, Inc., Quincy, MA 02269*

Reprinted with permission from NFPA 70-2002, The National Electrical Code®, 2002, National Fire Protection Association, Quincy, MA 02269. This reprinted material is not the complete and official position of the NFPA, on the referenced subject which is represented only by the standard in its entirety.

Separate overcurrent protection

A separate overcurrent device is not necessary when an ABB capacitor is electrically connected on the load side of the motor starter fused safety switch or breaker. Personnel and facility short circuit protection is provided within the capacitor by ABB's patented Sequential Protection System. Short circuit protection between the main feed and the capacitor is provided by the motor starter fused safety switch or breaker. A disconnect switch can be provided when the capacitor is connected as illustrated in Option C (See Fig. 12). When the capacitor is connected as shown in Option C, the capacitor remains energized when the motor is off. The optional disconnect switch provides a means to disconnect the capacitor when the motor is not in operation.

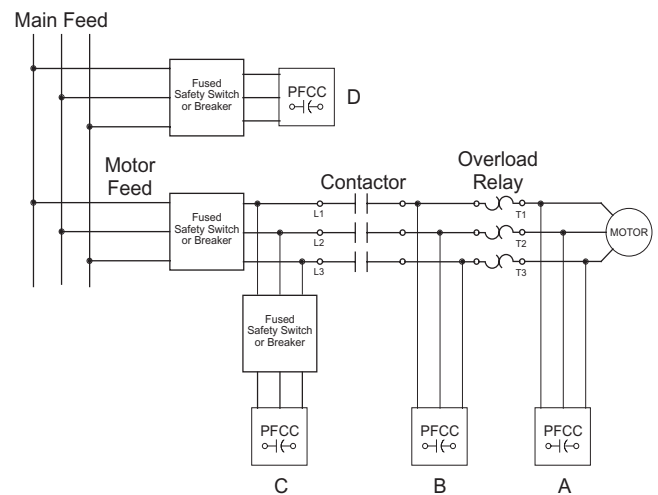

Fig. 12