

Circuit diagrams

2 Speed, 1 Winding; 2 Speed, 2 Winding

A9 – A750

00.00 Inches
00.00 [Millimeters]

2 Speed, 1 winding — constant or variable torque, selective control
A9 – A750 shown with control circuit transformer, HOA, STOP-FAST-SLOW

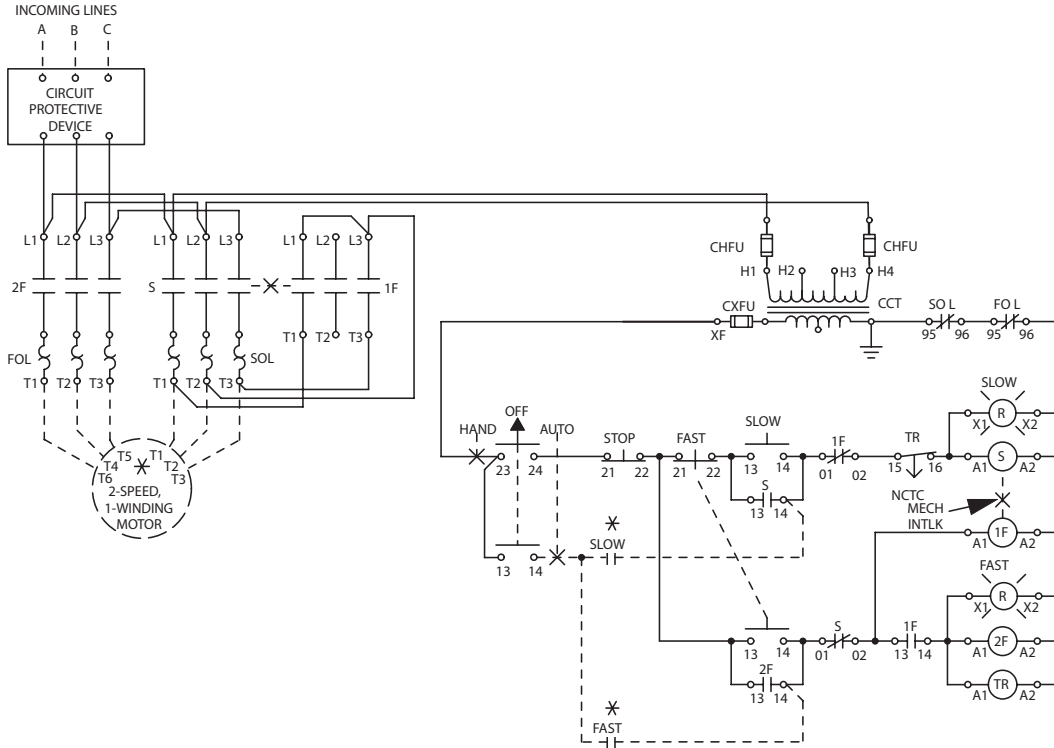

2 Speed, 2 winding
A9 – A750 shown with control circuit transformer, FAST-SLOW-OFF-AUTO

