

Type N, NE, NL & TNL Control relays

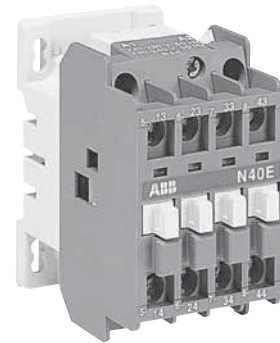

Control relays
Type N, NE, NL & TNL
Positive safety
AC/DC operated



7

Positive safety relays

There are many applications where safety is very critical and it is important to use electrical equipment which ensures that dangerous machine movement cannot occur when a fault is detected with the moving contacts during the cycle which the fault is indicated.

Regulations and standards have been written to ensure that safety is maintained:

- United States ANSI B11.19-1990
 ANSI B11.20-1991
- Germany SÜVA
 ZH1/457
- France INRS
- United Kingdom BIA
- Switzerland SA

The ABB Type N & NL 4 and 8 pole relays are designed with "Positive Guided" contacts and fulfill the regulations or standards shown. The relays can provide positive safety for the N.O. and N.C. contacts which assure that the N.O. contacts will not close before any N.C. contact opens. Therefore, if one of the contacts weld due to abnormal conditions in the control circuit, the other contacts will also remain in the same position as when the welding occurred. This means that the open contacts must maintain an air distance 0.5mm when the coil is energized at 110% Vc or when it is de-energized.

UL File No: E39231 (N & NL)

General information

Type N, AC operated

Description

- AC operated with laminated magnetic circuit.
- 2 versions: 4 pole or 8 pole. The width of 8 pole devices is identical to that of 4 pole devices; only the depth is increased.
- Side by side mounting possible.
- Self cleaning auxiliary contacts.
- Alone or by itself or with a 4 pole CA5 auxiliary contact block, these devices offer "positive safety" between their auxiliary contacts.

Application

Type N control relays are used for switching auxiliary circuits and control circuits.

7

Holes for screw mounting (screws not supplied). Distances between holes according to EN50 002.

Quick mounting on 35 x 7.5mm DIN mounting rail according to IEC715 and EN50 022.

Location of side mounted accessories: mounting on right or left hand side.

Terminals delivered in open position with captive screws (screws of unused terminals should be tightened).

Screwdriver guidance for all screws makes it possible to use motorized screwdrivers.

All terminals provide protection against accidental direct contact with live parts according to VDE0106 – Part. 100 and offer IP 20 degree of protection according to IEC947-1.

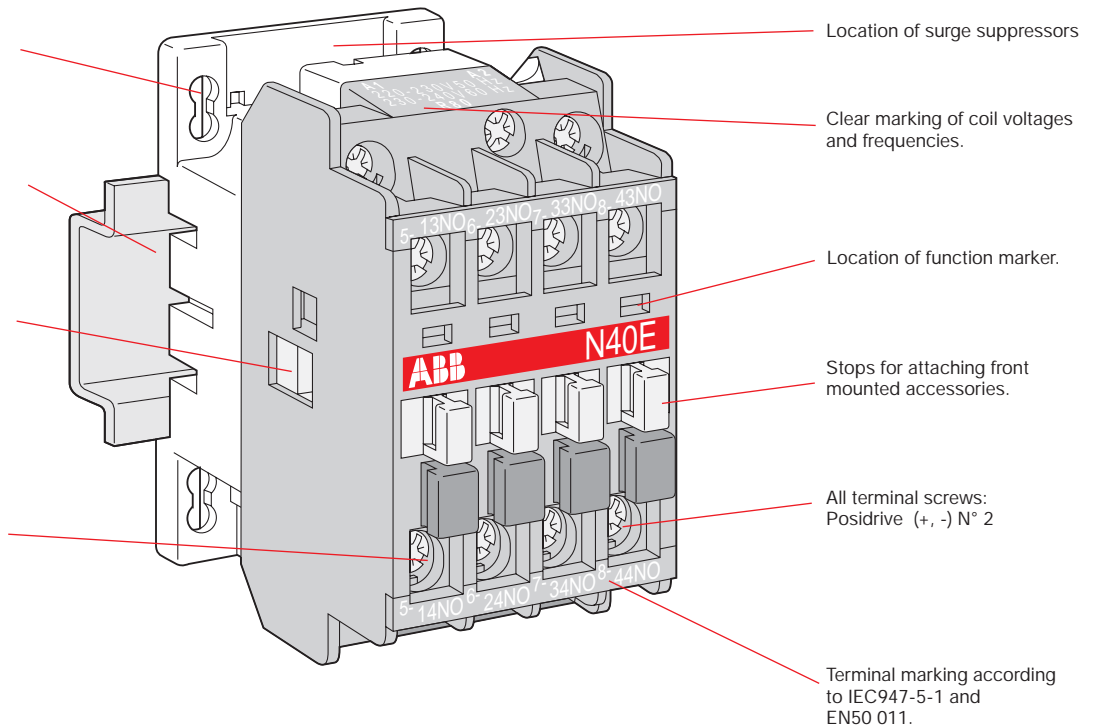

Catalog number explanation

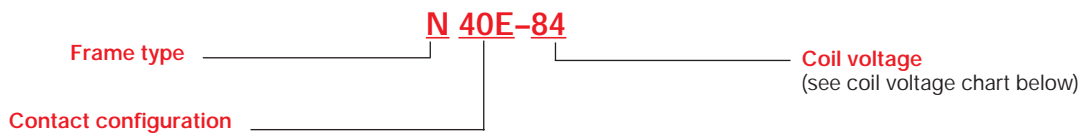

Coil voltage selection chart

| Hz | Relay type | Volts | | | | | | | | | | | | | | | |
|----|------------|-------|----|----|-----|-----|-----|-----|-----|-----|-----|-----|-----|-----|-----|-----|-----|
| | | 12 | 24 | 48 | 110 | 120 | 125 | 208 | 220 | 240 | 277 | 380 | 415 | 440 | 480 | 500 | 600 |
| 60 | N | | 81 | 83 | 84 | 84 | | 34 | 36 | 80 | 42 | | 86 | 86 | 51 | 53 | 55 |
| 50 | N | | 81 | 83 | 84 | | | | 80 | | | 85 | 86 | | | | |
| DC | NE, NL | 80 | 81 | 83 | 86 | | 87 | | 88 | 89 | | | | | | | |

General information

Type NE, DC operated

Description

- Contactor relays with laminated magnet circuit and double-winding coil fed from a DC supply via a built-in N.C. lagging auxiliary contact.
- 1-stack version with three built-in auxiliary contacts.
- Self-cleaning auxiliary contacts
- Alone or fitted with a 4-pole CA5 auxiliary contact block, these devices offer mechanically linked contacts.
- Side by side mounting possible.

Application

NE... contactor relays are used for switching auxiliary circuits and control circuits.

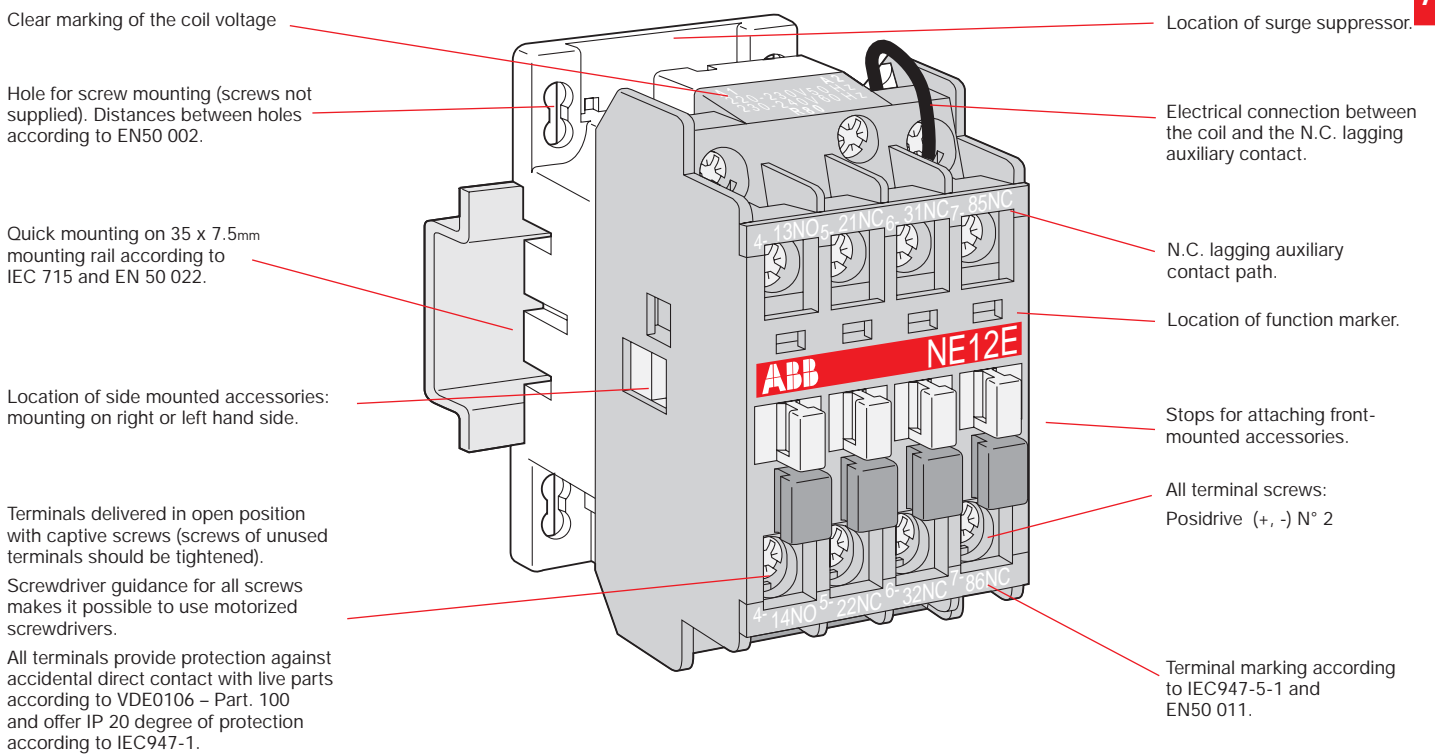

Catalog number explanation

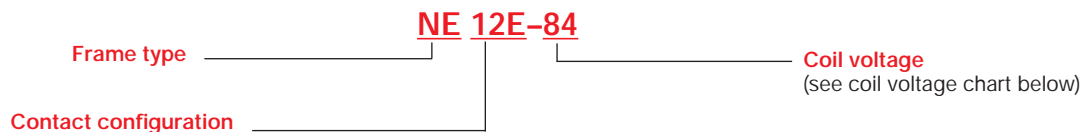

Coil voltage selection chart

| Hz | Relay type | Volts | | | | | | | | | | | | | | | |
|----|------------|-------|----|----|-----|-----|-----|-----|-----|-----|-----|-----|-----|-----|-----|-----|-----|
| | | 12 | 24 | 48 | 110 | 120 | 125 | 208 | 220 | 240 | 277 | 380 | 415 | 440 | 480 | 500 | 600 |
| 60 | N | | 81 | 83 | 84 | 84 | | 34 | 36 | 80 | 42 | | 86 | 86 | 51 | 53 | 55 |
| 50 | N | | 81 | 83 | 84 | | | | 80 | | | 85 | 86 | | | | |
| DC | NE, NL | 80 | 81 | 83 | 86 | | 87 | | 88 | 89 | | | | | | | |

General information

Type NL & TNL, DC operated

Type NL

Description

- Magnetic circuit variants: NL types: d.c. operated with solid magnetic circuits.
- 2 versions: 4 pole or 8 pole
The width of 8 pole devices is identical to that of 4 pole devices; only the depth is increased.
- Bifurcated auxiliary contacts.
- Alone or mounted with a 4 pole CA5 auxiliary contact block, these devices offer "positive safety" between their auxiliary contacts.

Application

Type NL control relays are used for switching auxiliary circuits and control circuits.

Type TNL

Description

- Magnetic circuit variants
 - NL types: D.C. operated with solid magnetic circuits.
 - TNL types: D.C. operated with solid magnetic circuit and large coil voltage range.
- 2 versions
 - 4-pole/1-stack or 8-pole/2-stack
 - The width of 8-pole devices is identical to that of 4 pole devices; only the depth is increased.
- Double sharp auxiliary contacts.
- Alone or mounted with a 4-pole CA 5 auxiliary contact block, these devices offer "positive safety" between their auxiliary contacts.

Application

Type NL and TNL control relays are used for switching auxiliary circuits and control circuits.

7

Location of surge suppressors.

Quick mounting on 35 x 7.5mm or 35 x 15mm DIN mounting rail according to IEC947-5-1 and EN50022.

Holes for screw mounting (screws not supplied). Distances between holes according to EN50002.

Terminals delivered in open position with captive screws (screws of unused terminal should be tightened).

Screwdriver guidance for all screws makes it possible to use motorized screwdrivers.

All terminals provide protection against accidental direct contact with live parts according to VDE0106 – Part. 100.

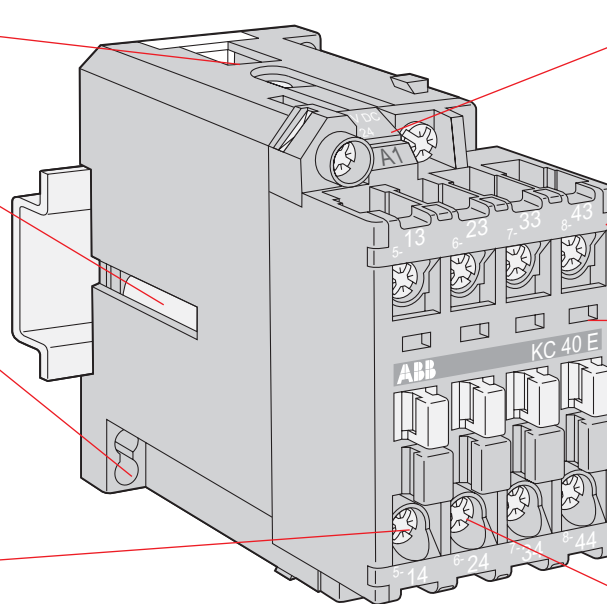

Clear marking of coil voltages.

Terminal marking according to IEC947-5-1 and EN50 011.

Location of function marker and surge suppressor.

Stops for attaching front mounted accessories.

All terminal screws: M 3.5, posidrive (+,-) N° 2

Catalog number explanation

(T)NL 44E-84

Frame type

Coil voltage

(see coil voltage chart below.)

Contact configuration

Coil voltage selection chart

| Hz | Relay type | Volts | | | | | | | | | | | | | | | |
|----|------------|-------|----|----|-----|-----|-----|-----|-----|-----|-----|-----|-----|-----|-----|-----|-----|
| | | 12 | 24 | 48 | 110 | 120 | 125 | 208 | 220 | 240 | 277 | 380 | 415 | 440 | 480 | 500 | 600 |
| 60 | N | | 81 | 83 | 84 | 84 | | 34 | 36 | 80 | 42 | | 86 | 86 | 51 | 53 | 55 |
| 50 | N | | 81 | 83 | 84 | | | | 80 | | | 85 | 86 | | | | |
| DC | NE, NL | 80 | 81 | 83 | 86 | | 87 | | 88 | 89 | | | | | | | |

Type N & NL AC & DC operated



N40E-1



NE12E-1

A.C. operated

| Contact configuration | | Catalog number | List price |
|-----------------------|------|----------------|--------------|
| N.O. | N.C. | | |
| 4 | 0 | N40E-84 | \$ 60 |
| 3 | 1 | N31E-84 | |
| 2 | 2 | N22E-84 | |
| 4 | 4 | N44E-84 | 120 |
| 5 | 3 | N53E-84 | |
| 6 | 2 | N62E-84 | |
| 7 | 1 | N71E-84 | |
| 8 | 0 | N80E-84 | |

Coil voltage selection

All AC operated catalog numbers include a 120VAC coil. All DC operated catalog numbers include a 110VDC coil. To select other coil voltages, substitute the code from the Coil Voltage Selection Chart for the first digit after the last dash in the catalog number.

Ex.: A 240V coil is required for an N80 control relay: N80E-80

Coil voltage selection chart

| Hz | Relay type | Volts | | | | | | | | | | | | | | | |
|----|------------|-------|----|----|-----|-----|-----|-----|-----|-----|-----|-----|-----|-----|-----|-----|-----|
| | | 12 | 24 | 48 | 110 | 120 | 125 | 208 | 220 | 240 | 277 | 380 | 415 | 440 | 480 | 500 | 600 |
| 60 | N | | 81 | 83 | 84 | 84 | | 34 | 36 | 80 | 42 | | 86 | 86 | 51 | 53 | 55 |
| 50 | N | | 81 | 83 | 84 | | | 80 | | | | 85 | 86 | | | 55 | |
| DC | NE, NL | 80 | 81 | 83 | 86 | | 87 | 88 | 89 | | | | | | | | |

D.C. operated

| Contact configuration | | Catalog number | List price |
|-----------------------|------|----------------|--------------|
| N.O. | N.C. | | |
| 4 | 0 | NL40E-86 | \$ 72 |
| 3 | 1 | NL31E-86 | |
| 2 | 2 | NL22E-86 | |
| 4 | 4 | NL44E-86 ① | 144 |
| 5 | 3 | NL53E-86 | |
| 6 | 2 | NL62E-86 | |
| 7 | 1 | NL71E-86 | |
| 8 | 0 | NL80E-86 | |
| 1 | 2 | NE12E-86 | 72 |
| 2 | 1 | NE21E-86 | |
| 3 | 0 | NE30E-86 | |
| 4 | 3 | NE43E-86 ① | 144 |
| 5 | 2 | NE52E-86 | |
| 6 | 1 | NE61E-86 | |
| 7 | 0 | NE70E-86 | |

Block diagrams for NE... contactor relay coil supply

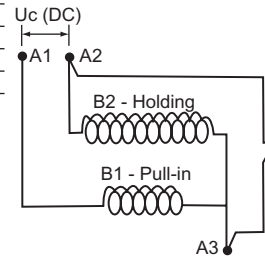

Coil supply $U_c < 110$ VDC

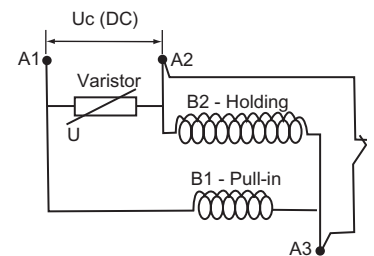

Coil supply via built-in varistor $U_c \leq 110$ VDC

① NE43 – NE70 and NL44 – NL62 control relays cannot accept any front mounted auxiliary contact blocks.

Type TNL 4 Pole & 8 Pole



TNL22E

4 Pole, 1 stack

| Number of contacts | | | | Weight | Catalog number | List price |
|--------------------|------|-----------|------|--------|----------------|------------|
| 1st stack | | 2nd stack | | | | |
| N.O. | N.C. | N.O. | N.C. | | | |
| 2 | 2 | - | - | 0.540 | TNL22E-★ | \$ 121 |
| 3 | 1 | - | - | 0.540 | TNL31E-★ | |
| 4 | - | - | - | 0.540 | TNL40E-★ | |

8 Pole, 2 stack

| Number of contacts | | | | Weight | Catalog number | List price |
|--------------------|------|-----------|------|--------|----------------|------------|
| 1st stack | | 2nd stack | | | | |
| N.O. | N.C. | N.O. | N.C. | | | |
| 4 | - | - | 4 | 0.600 | TNL44E-★ | \$ 180 |
| 4 | - | 2 | 2 | 0.600 | TNL62E-★ | |

★ - Substitute the ★ for the coil voltage code. See the Type TNL Coil voltage Selection chart beneath the photos.

Coil characteristics

No extra tolerances applicable to the U_c min. ... max. values quoted in the Coil voltage selection table

- Coil consumption at U_c max. $q = 20^\circ\text{C}$: 9 W pull-in/holding
- Replacement coils: consult us (standard coils used on NL control relays are not suitable for TNL control relays).

Coil voltage selection

| Min. U_c | Max | Voltage |
|------------|-----|---------|
| 17 | 32 | 51 |
| 24 | 45 | 52 |
| 36 | 65 | 54 |
| 42 | 78 | 58 |
| 50 | 90 | 55 |
| 77 | 143 | 62 |
| 90 | 150 | 66 |
| 152 | 264 | 68 |

Mounting distance – for coil operating limits U_c min. ... U_c max.

| A mm | B mm | Ambient temp. $^\circ\text{C}$ | Max. switching frequency Operating cycles/h |
|------|------|--------------------------------|--|
| 2 | 20 | ≤ 20 | 1200 |
| 5 | 20 | ≤ 55 | 1200 |

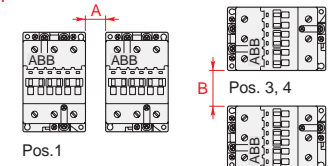

Add-on accessories

| Control relays | Max. number of auxiliary contact blocks | | | | | | Timer TP | Mechanical interlock | Label marker |
|--|---|--------|--------|--------|--------|--------|----------|----------------------|--------------|
| | CA5-10 | CA5-01 | CA5-40 | CA5-31 | CA5-22 | CA5-04 | | | |
| Pos. 1, 3 or 4 TNL 40-E | 4 | 2 | 1 | 1 | 1 | - | - | VBC 30 | BA 5-50 |
| Pos. 1, 3 or 4 TNL 31-E | 4 | 1 | 1 | 1 | - | - | - | VBC 30 | BA 5-50 |
| Pos. 1, 3 or 4 TNL 22-E | 4 | - | 1 | - | - | - | - | VBC 30 | BA 5-50 |
| Pos. 1 $\pm 30^\circ$ TNL - all types | - | - | - | - | - | - | - | VBC 30 | BA 5-50 |

Mounting positions

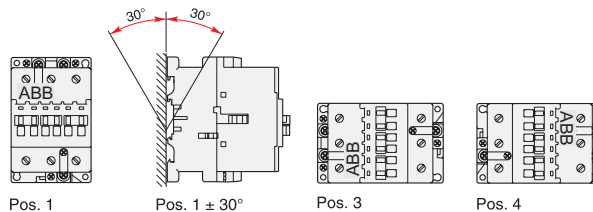

Accessories

Type N, NL & TNL

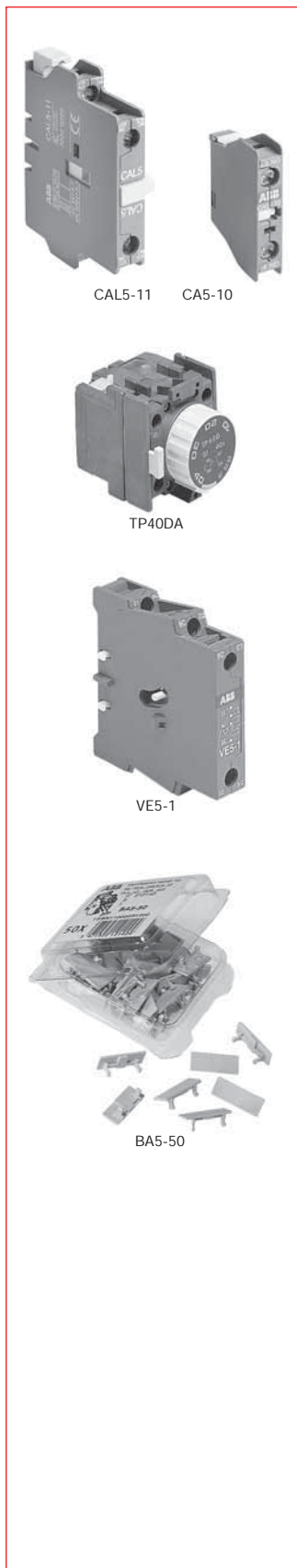

Auxiliary contact blocks

| Positioning | Contacts | | Catalog number | List price |
|------------------------------|----------|------|-------------------------------|------------|
| | N.O. | N.C. | | |
| N, NE, NL, TNL (front mount) | 1 | — | CA5-10 CA5-01 | \$ 15 |
| N, NL, NE, TNL (4 pole) | 4 | — | CA5-40N CA5-22N CA5-04N | 30 |
| | 2 | 2 | | |
| N, NE, NL, TNL (side mount) | — | 4 | CAL5-11 | |
| | 1 | 1 | | |

Pneumatic timers

| | Timing range | Contacts | | Catalog number | List price |
|------------------|---------------------|----------|------|--|------------|
| | | N.O. | N.C. | | |
| N, NL NE, TNL | On delay 0.1 – 40s | 1 | 1 | TP40DA TP180DA TP40IA TP180IA | \$ 108 |
| | On delay 10 – 180s | 1 | 1 | | |
| | Off delay 0.1 – 40s | 1 | 1 | | |
| | Off delay 10 – 180s | 1 | 1 | | |

Interlocks

| Feature | Contacts | | Catalog number | List price |
|--------------------------------------|----------|------|----------------|------------|
| | N.O. | N.C. | | |
| N, NE, NL, TNL Mechanical/electrical | — | 2 | VE5-1 | \$ 45 |
| N, NE, NL, TNL Mechanical | — | — | VM5-1 | 21 |

Mechanical latches

| Feature | Catalog number | List price |
|---------------------|----------------|------------|
| N, NL (4 pole only) | WB75A-★ | \$ 84 |

Coil voltage selection chart — mechanical latches

| 50 Hz | 60 Hz | Voltage code |
|-----------|-----------|--------------|
| 24 | 24 – 28 | 01 |
| 42 | 42 – 48 | 02 |
| 48 | 48 – 55 | 03 |
| 110 | 110 – 127 | 04 |
| 220 – 230 | 220 – 255 | 06 |
| 230 – 240 | 230 – 277 | 05 |
| 380 – 415 | 380 – 440 | 07 |
| 415 – 440 | 440 – 480 | 08 |

Identification markers

| Feature | Catalog number | List price |
|------------|----------------|------------|
| Pack of 50 | BA5-50 | \$ 15 |

Accessories

Type N, NL, NE & TNL



ZA16-84



RV5/50

RC5-1/50

Coils

| Relay type | Catalog number | List price |
|------------|----------------|------------|
| N | ZA16-★ | \$ 24 |
| NE | ZAE16-★ | 24 |

★ Select the coil voltage from the Control Relay Coil Voltage Selection chart and substitute the letter code for the ★ as the last digit in the catalog number.

Coil voltage selection chart

| Hz | Relay type | Volts | | | | | | | | | | | | | | | |
|----|------------|-------|----|----|-----|-----|-----|-----|-----|-----|-----|-----|-----|-----|-----|-----|-----|
| | | 12 | 24 | 48 | 110 | 120 | 125 | 208 | 220 | 240 | 277 | 380 | 415 | 440 | 480 | 500 | 600 |
| 60 | N | | 81 | 83 | 84 | 84 | | 34 | 36 | 80 | 42 | | 86 | 86 | 51 | 53 | 55 |
| 50 | N | | 81 | 83 | 84 | | | | 80 | | | | 85 | 86 | | 55 | |
| DC | NE, NL | 80 | 81 | 83 | 86 | | 87 | | 88 | 89 | | | | | | | |

Surge suppressors — for Type N control relays

| Feature | Type | Voltage range | Catalog number | List price |
|----------|------------------|------------------|----------------|------------|
| Varistor | N, NE NL, TNL | 24 – 50 VAC/DC | RV5/50 | \$ 30 |
| | | 50 – 133 VAC/DC | RV5/133 | |
| | | 110 – 250 VAC/DC | RV5/250 | |
| | | 250 – 440 VAC/DC | RV5/440 | |
| RC | N | 24 – 50 VAC | RC5-1/50 | \$ 30 |
| | | 50 – 133 VAC | RC5-1/133 | |
| | | 110 – 250 VAC | RC5-1/250 | |
| | | 250 – 440 VAC | RC5-1/440 | |

Technical data

| Type | Control circuit | Opening time growth factor | Residual overvoltage or clipping voltage | Remarks | |
|--|-----------------|----------------------------|--|---|---|
| RV5/... ing | AC/DC | 1.1 to 1.5 | 132V | Advantages | |
| | | | | Disadvantages | • Good energy absorption & damp- |
| | | | | | • Unpolarized system |
| | | | | | • Clipping from U_{vdr} thus voltage front up to this point |
| RC5-1/... or RC5-2/... RC-EH300/... | AC | 1.2 to 3 | 2 to 3 x U_c | Advantages | |
| | | | | • Very fast clipping | |
| | | | | • Attenuation of steep fronts and therefore, high frequencies | |
| | | | | • No operating delays | |

Accessory mounting information

Type N, NE, NL & TNL

4 Pole, N control relays

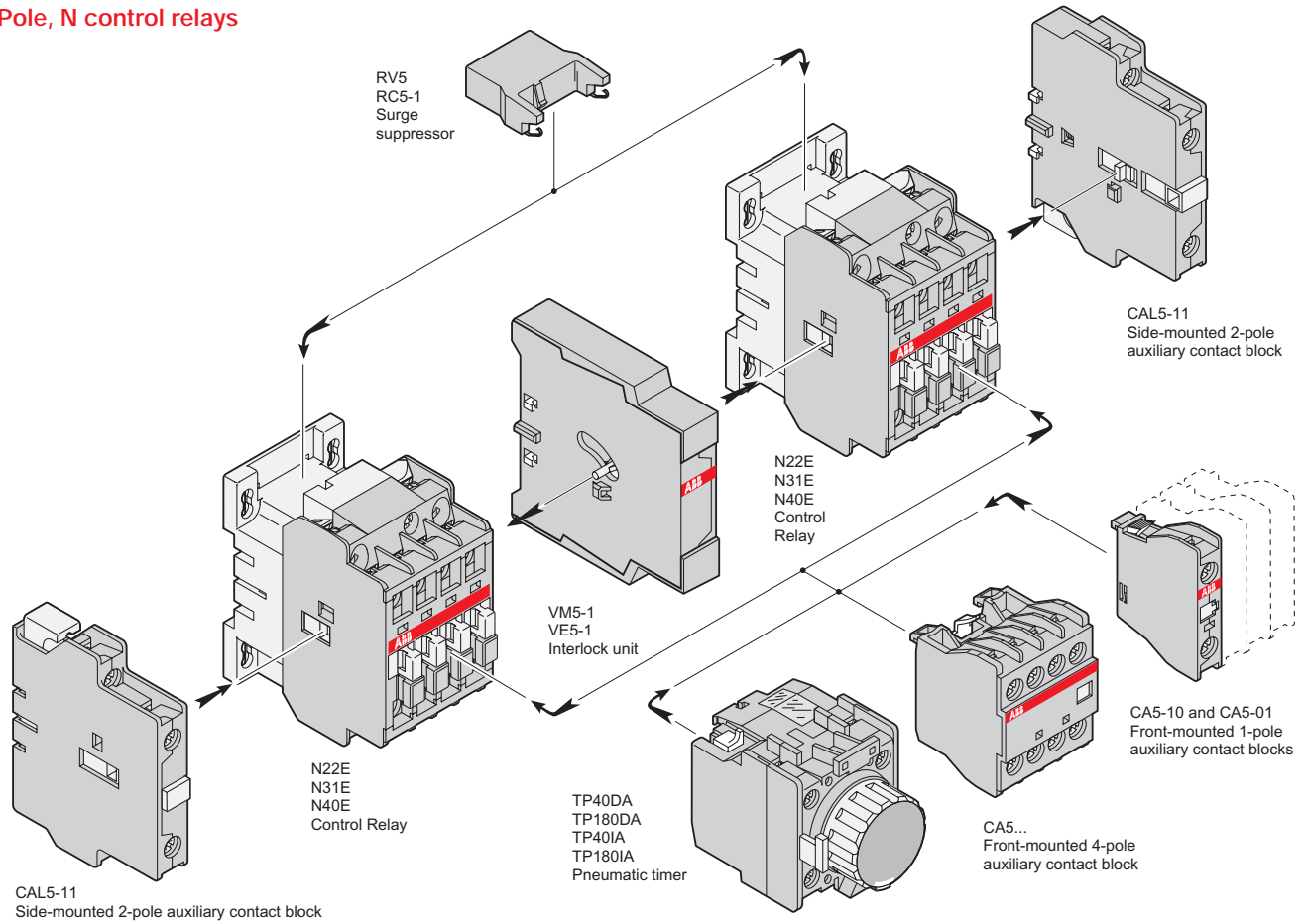



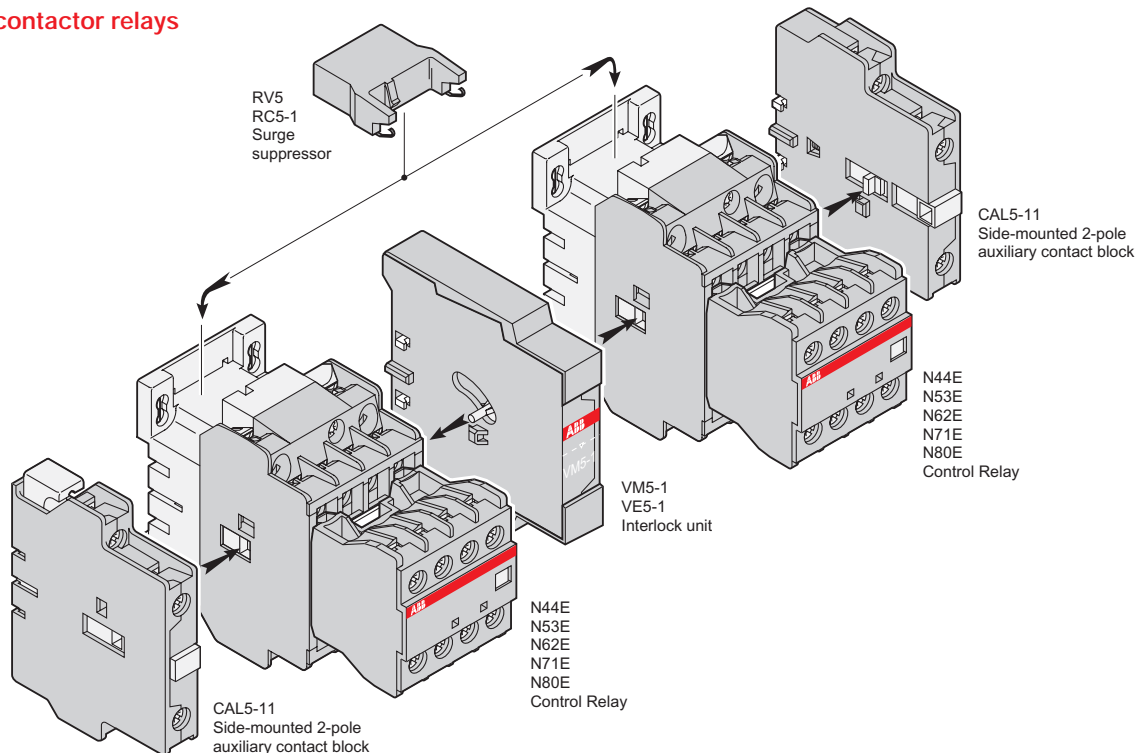





8 Pole, N contactor relays

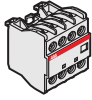
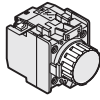
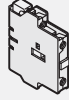

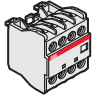
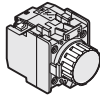
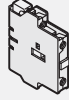
Possible accessory combinations

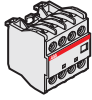
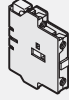
Type N, NE, NL, TNL

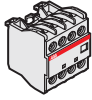
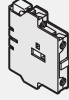
Configurations of accessories are different depending on whether front or side mounted.

| Type | Main poles | Built-in auxiliary contacts | Accessories — Front mounting | | | Accessories — Side mounting | |
|------|------------|-----------------------------|---|---|---|---|---|
| | | | Auxiliary contact blocks 1-pole CA5- | 4-pole CA5- | TP - A Pneumatic timer block | Auxiliary contact Blocks 2-pole CAL5-11 | Interlock units |
| N | ① 2 | 2 E |  |  |  |  |  |
| N | ① 3 | 1 E | 1 to 4 CA5- 1-pole blocks | 1 CA5- 4-pole block | or 1 TP - A block | + 1 to 2 CAL5-11 blocks | or 1 VM/ε5-1 block + 1 CAL5-11 block |
| N | ① 4 | 0 E | | | | | |
| N | 4 | 4 E | | | | | |
| N | 5 | 3 E | | | | | |
| N | 6 | 2 E | — | — | — | + 1 to 2 CAL5-11 blocks | or 1 VM/ε5-1 block + 1 CAL5-11 block |
| N | 7 | 1 E | | | | | |
| N | 8 | 0 E | | | | | |
| NE | ① 2 | 2 E |  |  |  |  |  |
| NE | ① 3 | 1 E | 1 to 4 CA5- 1-pole blocks | 1 CA5- 4-pole block | or 1 TP - A block | + 1 to 2 CAL5-11 blocks | or 1 VM/ε5-1 block + 1 CAL5-11 block |
| NE | ① 4 | 0 E | | | | | |
| NE | 4 | 4 E | | | | | |
| NE | 5 | 3 E | | | | | |
| NE | 6 | 2 E | — | — | — | + 1 to 2 CAL5-11 blocks | or 1 VM/ε5-1 block + 1 CAL5-11 block |
| NE | 7 | 1 E | | | | | |
| NE | 8 | 0 E | | | | | |
| NL | ① 2 | 2 E |  |  | — |  |  |
| NL | ① 3 | 1 E | 1 to 4 CA5- 1-pole blocks | 1 CA5- 4-pole block | or — | or 1 CAL5-11 block | or 1 VM/ε5-1 block + 1 CAL5-11 block |
| NL | ① 4 | 0 E | | | | | |
| NL | 4 | 4 E | | | | | |
| NL | 5 | 3 E | | | | | |
| NL | 6 | 2 E | — | — | — | or 1 CAL5-11 block | or 1 VM/ε5-1 block + 1 CAL5-11 block |
| NL | 7 | 1 E | | | | | |
| NL | 8 | 0 E | | | | | |
| TNL | ① 2 | 2 E |  |  | — |  |  |
| TNL | ① 3 | 1 E | 1 to 4 CA5- 1-pole blocks | 1 CA5- 4-pole block | or — | or 1 CAL5-11 block | or 1 VM/ε5-1 block + 1 CAL5-11 block |
| TNL | ① 4 | 0 E | | | | | |
| TNL | 4 | 4 E | | | | | |
| TNL | 5 | 3 E | | | | | |
| TNL | 6 | 2 E | — | — | — | or 1 CAL5-11 block | or 1 VM/ε5-1 block + 1 CAL5-11 block |
| TNL | 7 | 1 E | | | | | |
| TNL | 8 | 0 E | | | | | |

Technical data

UL & CSA



AC inductive ratings — NEMA A600

| Voltage | Continuous current | Maximum make | Maximum break |
|------------------------------|--------------------|--------------|---------------|
| 120V 240V 480V 600V | 10 | 7200VA | 720VA |

DC inductive ratings — NEMA P300

| Voltage | Continuous current | Maximum make | Maximum break |
|--------------------------|--------------------|--------------|---------------|
| 120V 250V 300-600V | 5 | 138VA | 138VA |

AC coil consumption

| In rush | Sealed |
|---------|--------|
| 80VA | 8VA |

DC coil consumption

| In rush | Sealed |
|---------|--------|
| 7.0W | 7.0W |

AC operating time

| Pickup | Dropout |
|-----------|-----------|
| 10 – 20ms | 10 – 20ms |

DC operating time

| Pickup | Dropout |
|-----------|-----------|
| 30 – 90ms | 10 – 20ms |

AC mechanical endurance
30 million operations

DC mechanical endurance
30 million operations

7

Technical data

Terminal marking and positioning

Type N

N control relays

Pole configuration schematics

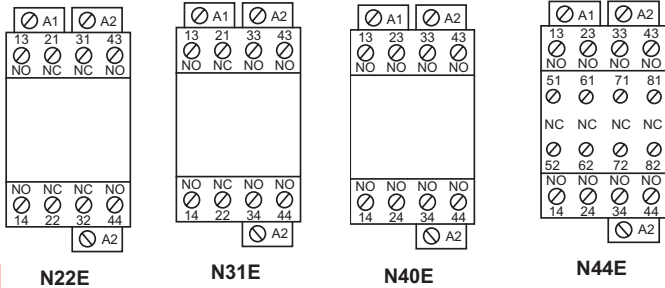

4 Pole control relay

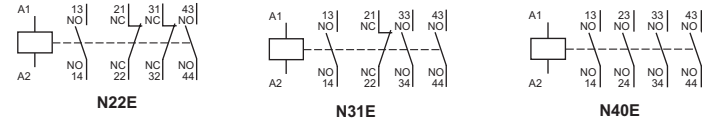

4 Pole control relay with 4 pole adder deck



7

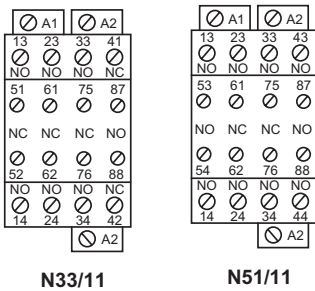
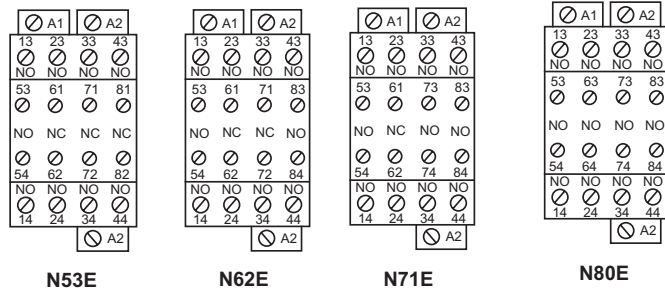

Other possible contact combinations with auxiliary contacts added by the user

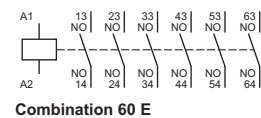
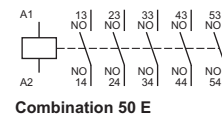
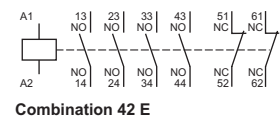
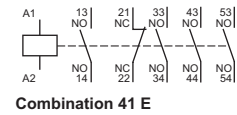
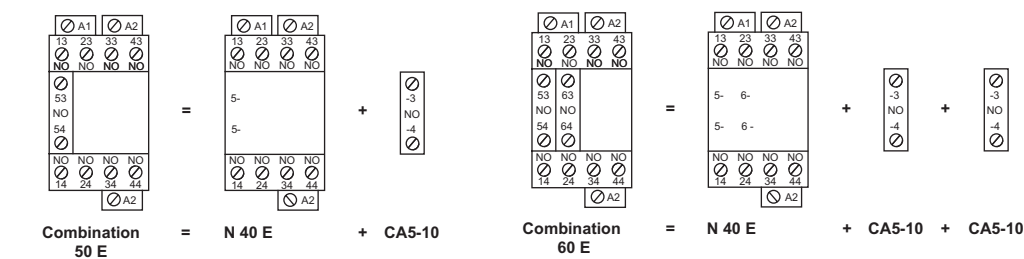
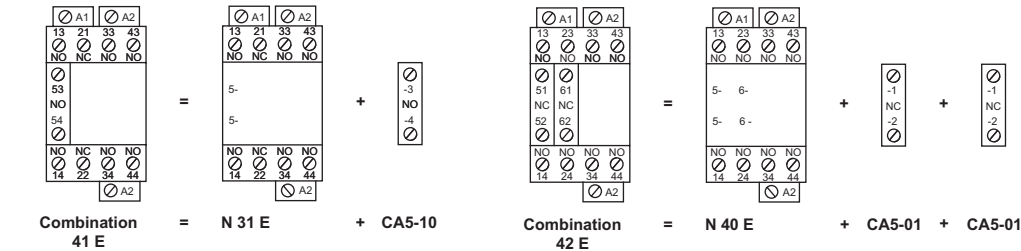

Technical data

Terminal marking and positioning

Type NE



NE control relays

Pole configuration schematics

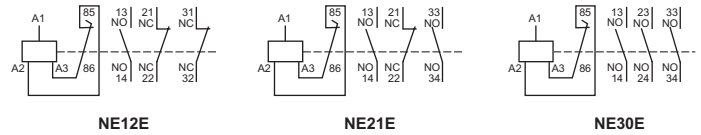
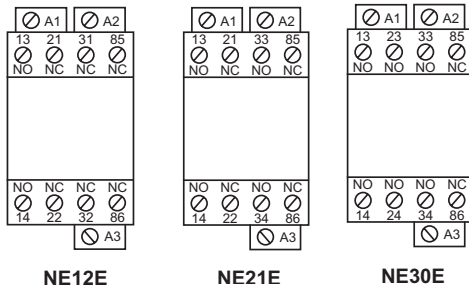

Technical data

Terminal marking and positioning

Type NL & TNL

Standard devices without addition of auxiliary contacts

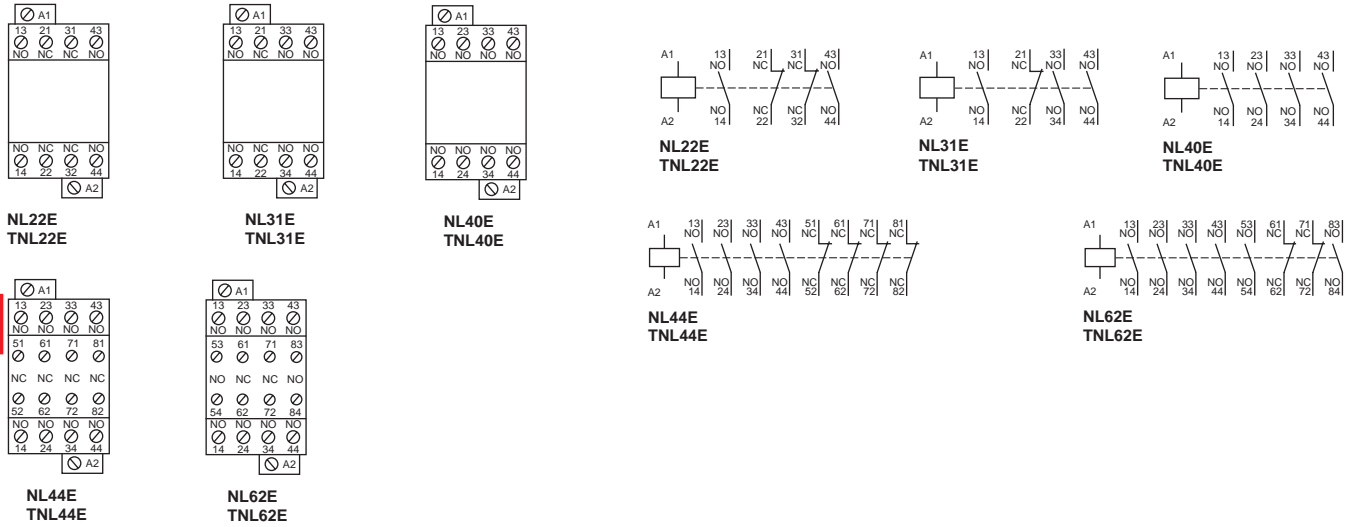

Other possible contact combinations with auxiliary contacts added by the user

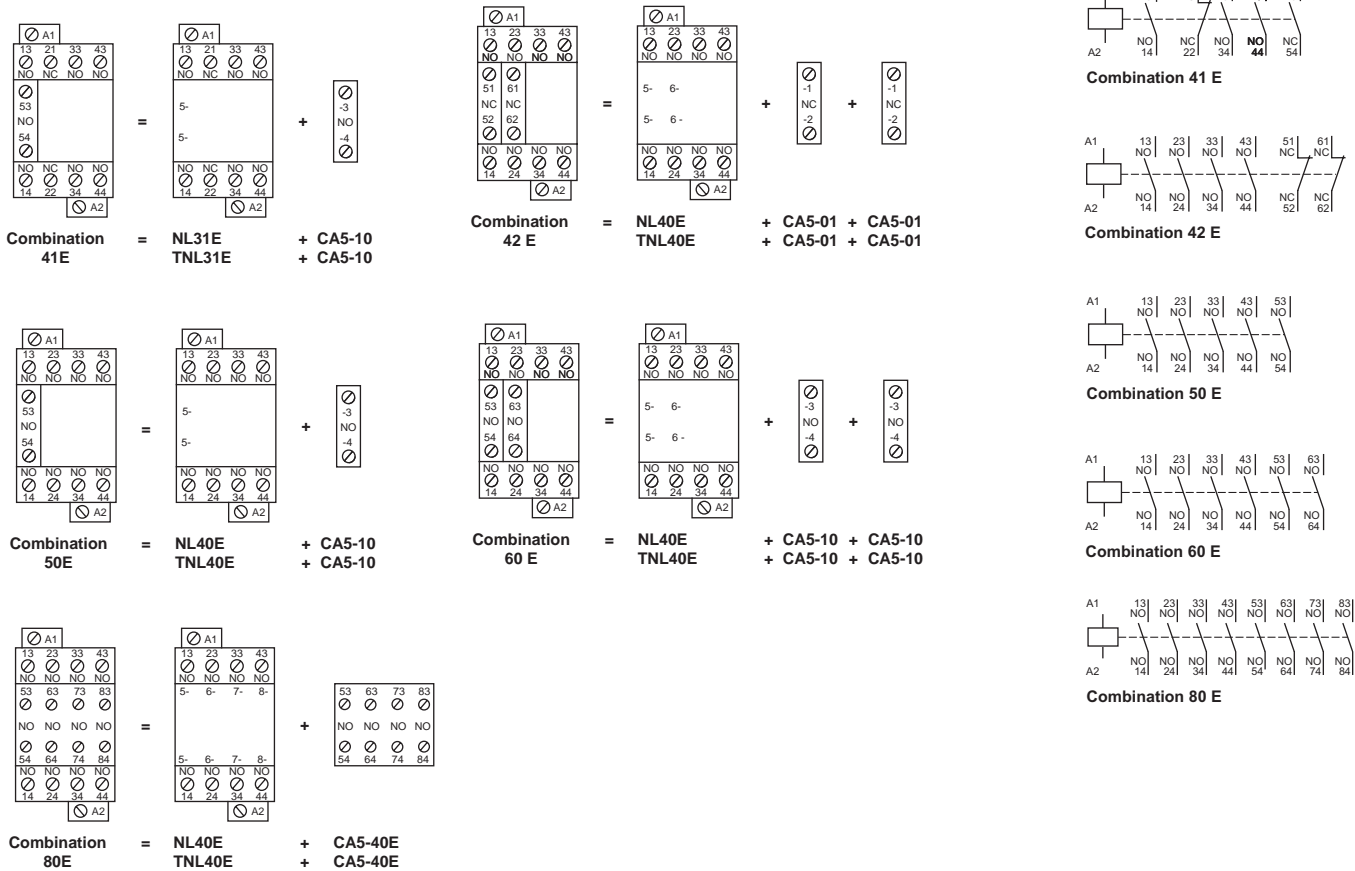

Technical data

IEC

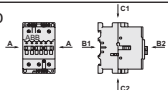
| Type | NE12, NE 21, NE 30 | N22, N31, N40 | N44, N53, N62, N71, N80 | NL22, NL31, NL40 | NL44, NL62 |
|--|--|---|--|------------------|------------|
| Number of poles | 3 | 4 | 8 | 4 | 8 |
| Insulation characteristics | | | | | |
| Rated insulation voltage U_i acc. to IEC947-5-1 and VDE0110 (Gr. C) | V | | 690 | | |
| acc. to UL/CSA | V | | 600 | | |
| Rated impulse withstand voltage U_{imp} acc. to IEC947-5-1 | kV | | 8 | | |
| General technical data | | | | | |
| Standards | Devices complying with international standards IEC947-5-1/947-4-1 and European standards EN60 947-5-1/60 947-4-1 Electromagnetic compatibility (EMC) according to amendment A11 to IEC947-1; EN60 947-1 and amendment 2 to IEC947-4-1 | | | | |
| Air temperature near contactor — for operation in free air: — for storage: | °C | -40 to +55 (0.85 – 1.1 U_c) / +55 to +70 (U_c) | | | |
| | °C | -60 to +80 | | | |
| Climatic withstand | according to IEC68-2-30 and 68-2-11 – UTE C63-100, Specification II | | | | |
| Mounting positions | Positions 1 to 5 - $\theta \leq 55^\circ\text{C}$: 0.85 – 1.1 - $\theta = 55 - 70^\circ\text{C}$: | | | | |
| (see diagrams below) | Position 6 | - $\theta \leq 55^\circ\text{C}$: 0.95 – 1.1 - $\theta > 55^\circ\text{C}$: not acceptable | unauthorized | | |
| Operating altitude | m | ≤ 3000 | | | |
| Shock withstand according to IEC 68-2-27 and EN 60068-2-27 Mounting pos. 1 (see below) |  | | 1/2 sinusoidal shock, 11ms: no change in contact position | | |
| | | | Shock direction: A, C1, C2 : 20 g B1 : 5 g B2 : 15 g | | |
| Mounting — on mounting rail — with screws (not supplied) | 35mm according to IEC715 and EN50022 2 x M4 | | | | |
| Connection terminals (delivered in open position, screws of unused terminals must be tightened) | M 3.5 (+,-) posidrive 2 screw with cable clamp | | | | |
| Connection capacity | Rigid solid | 1 x AWG 2 x AWG | 16 – 12 16 – 12 | | |
| Degree of protection according to IEC529, IEC947-1 and EN60529 — Pole terminals — Coil terminals | | | IP20 IP20 | IP20 IP20 | |

Mounting positions

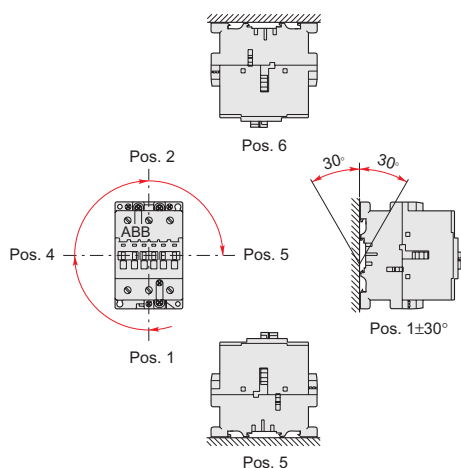

Electrical durability of contacts

utilization category AC – 15 according to IEC947-5-1

making current: 10 x

breaking current:

I_e with $\cos \varphi = 0.7$ and U_e

I_e with $\cos \varphi = 0.4$ and U_e

The curves opposite show the electrical durability of the control relays as well as the add-on auxiliary contact blocks in relation to the breaking current I_c . These curves have been drawn for resistive and inductive loads up to 690V, 40 – 60Hz.

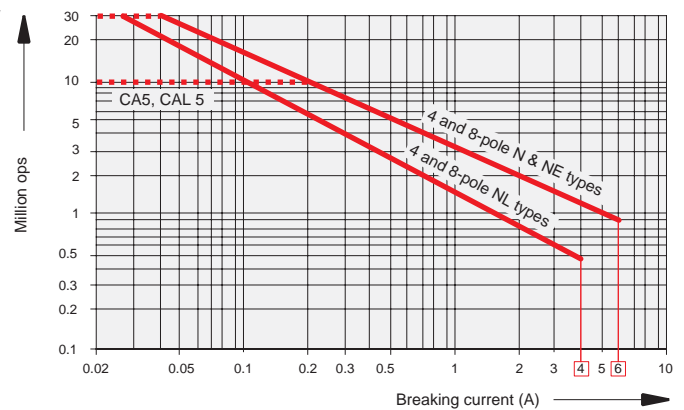

| Type | NE12, NE21, NE30 | N22, N31, N40 | N44, N53, N62, N71, N80 | NL22, NL31, NL40 | NL44, NL62 |
|---|------------------|---|-------------------------|------------------|------------|
| Number of poles | 3 | 4 | 8 | 4 | 8 |
| Pole utilization characteristics | | | | | |
| Rated operational voltage U_e V | 690 | | | | |
| Conventional thermal current in free air I_{th} according to IEC947-5-1 $\theta \leq 40^\circ\text{C}$ | A | 16 | | 16 | |
| Rated operating current I_e | | | | | |
| in AC-15 according to IEC947-5-1 | | | | | |
| 24 – 127 V 50/60 Hz | A | 6 | | 6 | |
| 230 – 240 V 50/60 Hz | A | 4 | | 4 | |
| 400 – 415 V 50/60 Hz | A | 3 | | 3 | |
| 500 V 50/60 Hz | A | 2 | | 2 | |
| 690 V 50/60 Hz | A | 2 | | 2 | |
| in DC-13 according to IEC947-5-1 | | | | | |
| 24VDC | A/W | 6/144 | | 6/144 | |
| 48VDC | A/W | 2.8/134 | | 2.8/134 | |
| 72VDC | A/W | 1/72 | | 1/72 | |
| 125VDC | A/W | 0.55/69 | | 0.55/69 | |
| 250VDC | A/W | 0.3/75 | | 0.3/75 | |
| Field of rated frequencies | Hz | 25 – 400 | | | |
| Mechanical durability in operating cycles | | 10 million | > 20 million | 30 million | |
| Max. switching frequency | cycles/h | 3000 | 6000 | 6000 | |
| Electrical durability in operating cycles | | 1200 | | | |
| Max. switching frequency | cycles/h | 1200 | | | |
| Rated making capacity according to IEC947-5-1 | | 10 x I_e /AC-15 | | | |
| Rated breaking capacity according to IEC947-5-1 | | 10 x I_e /AC-15 | | | |
| gG (gl) protection fuse | A | 10 | | | |
| Rated short time withstand current | | | | | |
| at ambient temp. of 40 °C, | 1.0 s | 100A | | 50A | |
| in free air, from cold state | 0.1 s | 140A | | 100A | |
| Insulation resistance at 500 VDC | | after durability test: 5 M Ω | | | |
| Min. switching capacity | | | | | |
| with failure rate below 10 ⁻⁶ | | 17V / 5mA | | 24V / 5mA | |
| Non overlapping time between N.O. and N.C. contacts | ms | ≥ 2 | | | |
| Power loss per pole at 6A | W | 0.10 | | 0.15 | |
| Magnet system characteristics | | | | | |
| Coil operating limits $\theta \leq 40^\circ\text{C}$ | | according to IEC 947-5-1 : 0.85 - 1.1 U_c | | | |
| Drop out voltage in % of U_c | | 10 – 30% | roughly 40 – 65% | roughly 10 – 30% | |
| Coil consumption (average value) | | | | | |
| — a.c. operation: 50 Hz pull in | VA | — | 70 | — | |
| 60 Hz pull in | VA | — | 80 | — | |
| 50/60 Hz ^① pull in | VA/VA | — | 74/70 | — | |
| 50/60Hz holding | VA/W | — | 8/2 | — | |
| — d.c. operation: cold pull in | W | 90 | — | 3 | |
| warm holding | W | 2 | — | 3 | |
| Rated control voltage U_c | | | | | |
| — AC operation: 50/60 Hz | V | — | 20 – 690 | — | |
| — DC operation: | VDC | 12 – 250 | — | 12 – 240 | |
| Max. permissible short supply interruption | | | | | |
| without opening of contacts | ms | 2 | 2 | 2 | |
| Operating time | | | | | |
| between coil energization and: | | | | | |
| — closing of N.O. contact | ms | 10 – 16 | 10 – 26 | 100 | |
| — opening of N.C. contact | ms | 8 – 12 | 7 – 21 | 20 – 70 | |
| between coil de energization and: | | | | | |
| — opening of N.O. contact | ms | 5 – 14 | 4 – 11 | 10 – 17 | |
| — closing of N.C. contact | ms | 11 – 17 | 9 – 16 | 16 – 27 | |

① 50/60 Hz coils: voltage codes 80 to 88, see page 7.5.

Approximate dimensions

Type N, NE, NL, & TNL

AC & DC operated

00.00
00.00 Inches
[Millimeters]

Type N, 4 Pole, AC operated

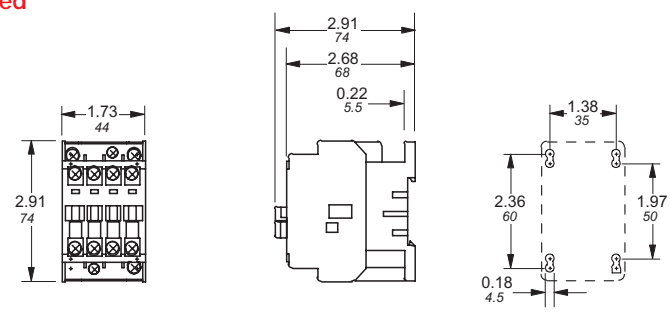

Type NE, 4 Pole, DC operated

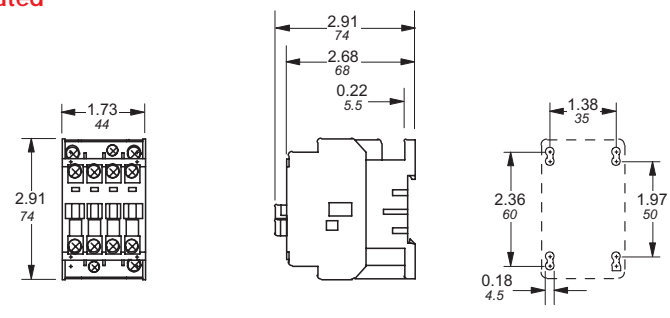

Type NL, TNL

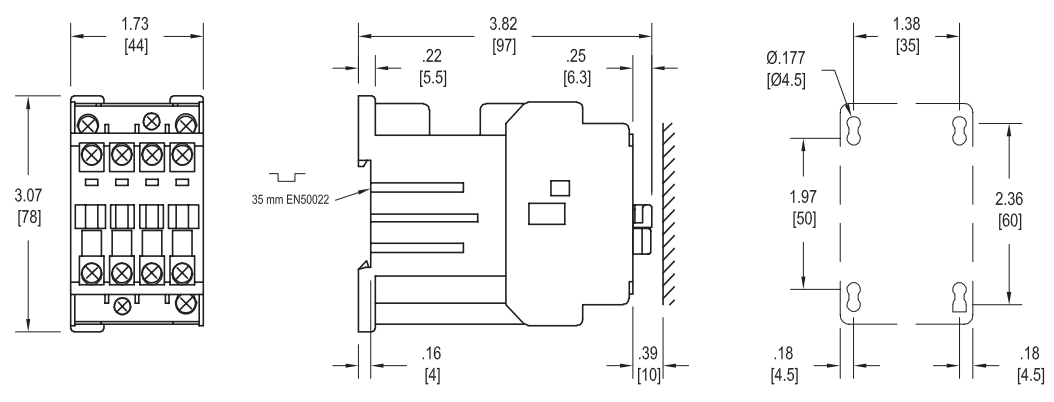

Approximate dimensions Accessories for Type N & NE

N & NE

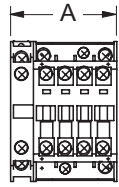

SIDE MOUNTED
AUXILIARY

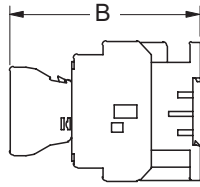

SINGLE POLE
TOP MOUNTED
AUXILIARY

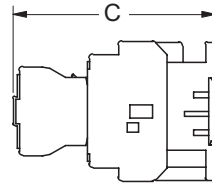

FOUR POLE
TOP MOUNTED
AUXILIARY

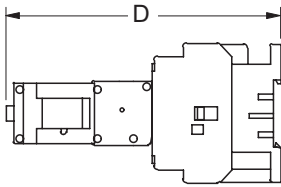

ON-POSITION
LATCH

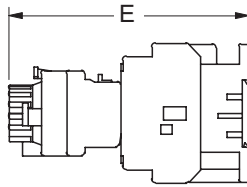

PNEUMATIC
TIMER

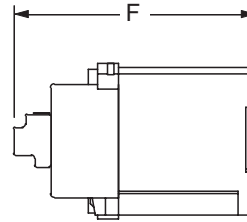

MECH INTERLOCK D.C.
OPERATED

| Type | | A | B | C | D | E | F |
|------|----|------|-------|------|------|------|---|
| N | IN | 2.20 | 3.96 | 4.21 | 5.71 | 5.00 | — |
| | MM | 56 | 100.5 | 107 | 145 | 127 | — |
| NE | IN | 2.20 | 3.96 | 4.21 | 5.71 | 5.00 | — |
| | MM | 56 | 100.5 | 107 | 145 | 127 | — |