

General information

Type NE, DC operated

Description

- Contactor relays with laminated magnet circuit and double-winding coil fed from a DC supply via a built-in N.C. lagging auxiliary contact.
- 1-stack version with three built-in auxiliary contacts.
- Self-cleaning auxiliary contacts
- Alone or fitted with a 4-pole CA5 auxiliary contact block, these devices offer mechanically linked contacts.
- Side by side mounting possible.

Application

NE... contactor relays are used for switching auxiliary circuits and control circuits.

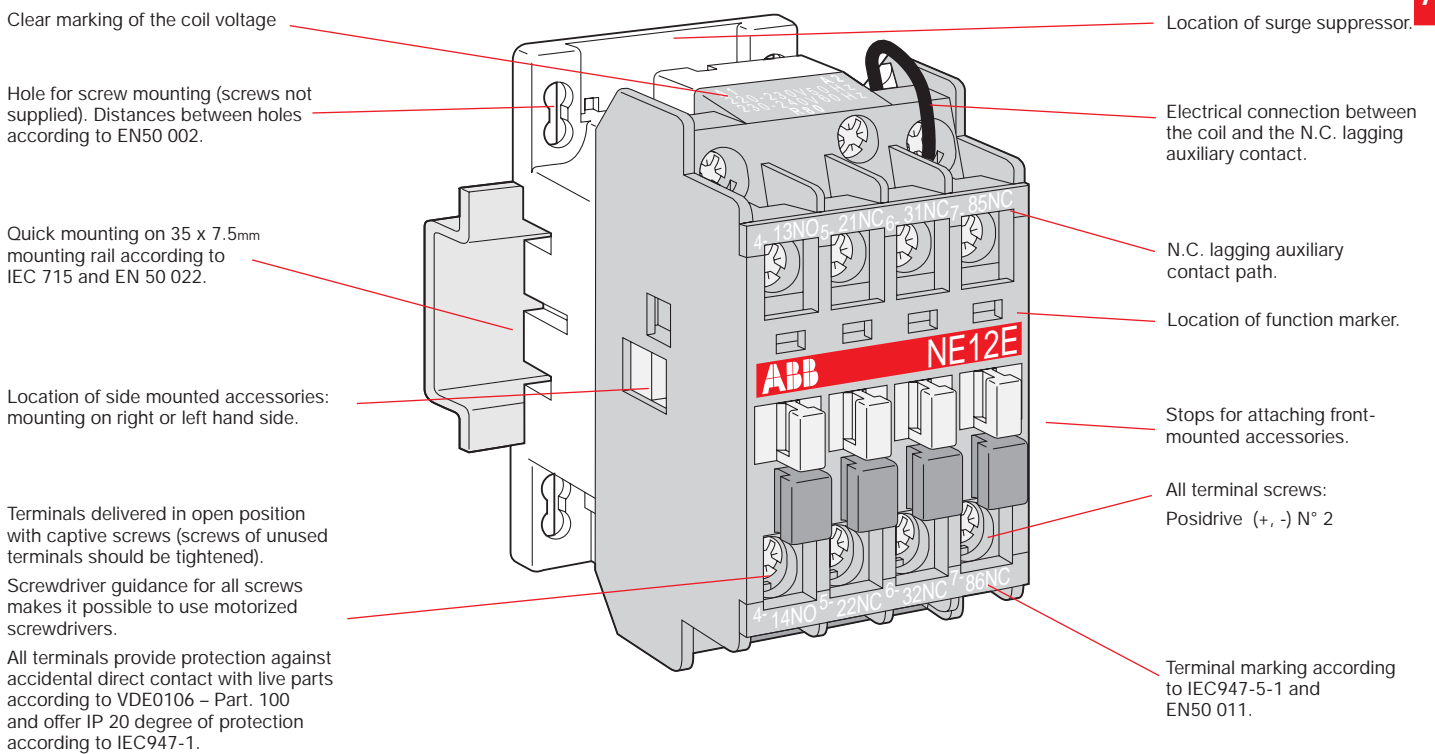

Catalog number explanation

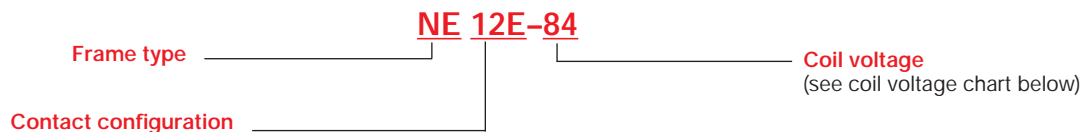

Coil voltage selection chart

Hz	Relay type	Volts															
		12	24	48	110	120	125	208	220	240	277	380	415	440	480	500	600
60	N		81	83	84	84		34	36	80	42		86	86	51	53	55
50	N		81	83	84				80			85	86				
DC	NE, NL	80	81	83	86		87		88	89							