

Electronic Safety relays

ABB Electronic relays
Safety

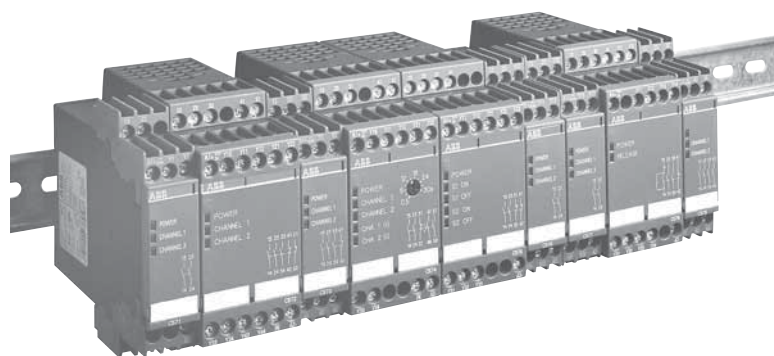

7

Description

The C57x series covers 10 safety relays which perform safety functions on machines. Their fields of application extend from emergency-stop circuits through guard door monitoring functions and tread mats to presses and punches. All C57x products are UL Listed, CSA approved and bear the CE Mark.

All safety relays can be used on the basis of their classification into the risk categories to EN 954-1, they are approved by the employers' liability insurance associations and/or the German Technical Inspection Authority (TÜV) and comply with the requirements of EN 60204, Part 1.

Redundancy is achieved by series-connection of two N.O. contacts. These N.O. contacts are located in two mutually independent, positive-action, all-or-nothing relays which monitor each other by means of a special-purpose circuit.

Diversity is provided thanks to the combination of N.C. contact and N.O. contact. Cyclic monitoring of the safety circuit in each On/Off cycle ensures maximum reliability.

Thanks to the two-channel control and/or control which is immune to shorts across

contacts, it is also possible to monitor signalling devices such as emergency-stop buttons or limit switches of the guard doors. This ensures the required level of safety even on systems subject to a high level of pollution.

In the event of a fault or error, the safe state of the system is achieved directly after opening the safety contacts. These enable circuits are N.O. contacts which open reliably in the event of fault or error and thus reliably switch off the potentially hazardous drives or machines.

Additional signalling contacts, N.C. contacts which close in the event of a fault or error or semiconductor outputs, are available, depending on the type of equipment.

Easy, reliable and fast wiring is achieved by a clear and manageable terminal designation system. This allows wiring errors to be minimized.

In addition to all these safe features, the C57x safety relays correspond to the product design of ABB's range of switchgear and control systems. They fit in perfectly with the overall design of the switch cabinet.

Type C570



C570

Voltage range		Output contacts			Safety category	Weight (oz.)	Piece per unit	Catalog number	List price
50/60Hz	VDC	Enable contacts	Instantaneous	Time delay					
—	24VDC							1SAR501042R0003	\$ 870
24VAC	—	4 N.O.	—	1 N.C.	3	33.86	1	1SAR501042R0002	
110VAC	—			1 N.O.				1SAR501042R0004	
230VAC	—							1SAR501042R0005	

Description

- Single channel connection
- Feedback circuit for monitoring external contactors
- LED indicators for power and operation
- Output: 4 N.O. and 1 N.O. & 1 N.C. positively driven
- Overall width: 75mm

Application

The safety relay can be used to monitor Emergency Stop circuits and for monitoring of other protective devices (i.e., safety gates).

Type C571



C571

Voltage range		Output contacts			Safety category	Weight (oz.)	Piece per unit	Catalog number	List price
50/60Hz	VDC	Enable contacts		Auxiliary					
		Instan-taneous	Time delay						
24VAC	24VDC	2 N.O.	—	—	3, (4)ⓐ	8.47	1	1SAR501020R0001 1SAR501020R0003 1SAR501020R0004 1SAR501020R0005	\$ 280
	24VDC	2 N.O.			3, (4)ⓐ				
115 VAC	—	2 N.O.			3, (4)ⓐ				
230 VAC	—	2 N.O.			3, (4)ⓐ				

Description

Emergency Stop monitor and safety gate monitor C571

- Auto-start / monitored start
- Operating voltage Vc at Emergency Stop button or limit switch
- Feedback loop for monitoring of external contactors
- LED indicators for power, channel 1 and 2
- Safety outputs: 2 N.O. contacts, positively guided
- Width of enclosure: 22.5mm

Application

Use the safety control gears C571/C573 in Emergency Stop devices as per EN418 and in safety circuits as per VDE 0113 Part 1 (11.98) and/or EN 60 204-1 (11.98), e.g., with moveable covers and guard doors. Depending on the external connections, categories 3 and 4 (with additional external measures) as per DIN EN 954-1 are achievable.

ⓐ Possible with additional external measures. The digit in parenthesis applies only if the cables and sensors are laid safely and protected mechanically.

Type C572



C572

Voltage range		Output contacts			Safety category	Weight (oz.)	Piece per unit	Catalog number	List price
50/60Hz	VDC	Enable contacts		Auxiliary					
		Instantaneous	Time delay						
—	24VDC	—	—	—	4	0.360	1	1SAR501032R0003	\$ 520
24VAC	—	3 N.O.	—	2 N.C.		0.450			
110VAC	—	3 N.O.	—	2 N.C.		0.450			
230VAC	—	3 N.O.	—	2 N.C.		0.360			

Description

Emergency Stop monitor and safety gate monitor C572

- Auto-start / monitored start
- 24 VDC at Emergency Stop button or limit switch
- Cross-short circuit detection at Emergency Stop button or limit switch
- Feedback loop for monitoring of external contactors
- LED indicators for power, channel 1 and 2
- Safety outputs: 3 NO contacts positively guided
- Signalling contacts: 2 NC contacts positively guided
- Width of enclosure: 45mm

Application

Use safety control gear C572 in Emergency Stop devices as per EN 418, in safety circuits as per VDE 0113 Part 1 (06.93) and/or EN 60 204-1 (12.97), e.g. with moveable covers and guard doors. Depending on the external connection, safety category 4 as per DIN EN 945-1 is achievable with this device.

Type C573



C573

Voltage range		Output contacts			Safety category	Weight (oz.)	Piece per unit	Catalog number	List price
50/60Hz	VDC	Enable contacts	Auxiliary						
		Instan-taneous	Time delay						
24VAC	24VDC	3 N.O.	—	1 N.C.	3, (4) ^①	8.47	1	1SAR501031R0001	\$ 340

Description

- Operating voltage U_e at Emergency-Stop button or limit switch
- Single or two-channel connection
- Feedback circuit for monitoring external contactors
- LED indicators for Power, Channels 1 and 2
- Output: 3NO and 1 NC positively driven
- Overall width: 45mm

Application

The safety relays C571/C573 can be used in Emergency Stop circuits as per EN 418 and in safety circuits as per VDE 0113 Part 1 (11.98) and/or EN 60 204-1 (11.98), i.e., with movable covers and guard doors. Depending on the external connections, categories 3 and 4 (with additional external measures) as per DIN EN 954-1 are achievable.

7

^① Possible with additional external measures. The digit in parenthesis applies only if the cables and sensors are laid safely and protected mechanically.

Type C574



C574

Voltage range		Output contacts			Safety category	Weight (oz.)	Piece per unit	Catalog number	List price
50/60Hz	VDC	Enable contacts		Auxiliary					
		Instantaneous	Time delay						
—	24VDC				3, (4) ①	15.87	1	1SAR503041R0003 1SAR503041R0002 1SAR503041R0004 1SAR503041R0005	\$ 675
24VAC	—	2 N.O.	2 N.O.	1 N.C.					
110VAC	—								
230VAC	—								

Description

Emergency Stop switching device and safety door monitor with time delay C574

- Single or two-channel connection
- Feedback circuit for monitoring external contactors
- LED indicators for Power, Channels 1 and 2, delayed channel 1/2
- Release time adjustable steplessly up to 30 s
- Output: 2 NO, 1 NC, 2 NO time-delayed
- Overall width: 45 mm

Application

The safety relay C574 can be used in Emergency Stop devices as per EN 418, in safety circuits as per VDE 0113 Part 1 (06.93) and/or EN 60 204-1 (12.97), such as for monitoring safety gates, or in circuits with controlled stand-still requirement (Stop Category 1). Depending on the external circuitry, this device can be used to realize Safety Category 4 instantaneous release circuits and Safety Category 3 delayed release circuits according to DIN EN 954-1.

• Delay time, 0.5 to 30 s stepless adjustment

• Auto-start

—	24VDC	2 N.O.	2 N.O.	1 N.C.	3, (4) ①	15.17	1	1SAR503141R0003	\$ 675
24VAC	—	2 N.O.	2 N.O.	1 N.C.	3, (4) ①	21.16	1	1SAR503141R0002	
110VAC	—	2 N.O.	2 N.O.	1 N.C.	3, (4) ①	21.16	1	1SAR503141R0004	
230VAC	—	2 N.O.	2 N.O.	1 N.C.	3, (4) ①	15.17	1	1SAR503141R0005	

• Delay time, 0.05 to 3 s stepless adjustment

• Monitoring-start

—	24VDC	2 N.O.	2 N.O.	1 N.C.	3, (4) ①	15.17	1	1SAR533241R0003	\$ 675
24VAC	—	2 N.O.	2 N.O.	1 N.C.	3, (4) ①	21.16	1	1SAR533241R0002	
110VAC	—	2 N.O.	2 N.O.	1 N.C.	3, (4) ①	21.16	1	1SAR533241R0004	
230VAC	—	2 N.O.	2 N.O.	1 N.C.	3, (4) ①	15.17	1	1SAR533241R0005	

• Auto-start

—	24VDC	2 N.O.	2 N.O.	1 N.C.	3, (4) ①	15.17	1	1SAR533141R0003	\$ 675
24VAC	—	2 N.O.	2 N.O.	1 N.C.	3, (4) ①	21.16	1	1SAR533141R0002	
110VAC	—	2 N.O.	2 N.O.	1 N.C.	3, (4) ①	21.16	1	1SAR533141R0004	
230VAC	—	2 N.O.	2 N.O.	1 N.C.	3, (4) ①	15.17	1	1SAR533141R0005	

① Possible with additional external measures. The digit in parenthesis apply only if the cables and sensors are laid safely and protected mechanically.

Type C575



C575

Voltage range		Output contacts			Safety category	Weight (oz.)	Piece per unit	Catalog number	List price
50/60Hz	VDC	Enable contacts		Auxiliary					
		Instantaneous	Time delay						
—	24VDC								
24VAC	—	2 N.O.	—	2 N.C.	4	12.35	1	1SAR504022R0003	\$ 780
110VAC	—							1SAR504022R0002	
230VAC	—							1SAR504022R0004	
	—							1SAR504022R0005	

Description

Two-hand control C 575

- For activating presses (e.g. in conjunction with overtravel monitor C 578)
- 24 V DC at the two-hand control switches
- Feedback circuit for monitoring external contactors
- 5 LED circuit state indicators for Power, S1 ON, S1 OFF, S2 ON, S2 OFF
- Simultaneity monitoring: 0.5 s
- Output: 2 NO, 2 NC positively driven
- Overall width: 45 mm

Application

C575 is suitable for installation in controls for presses.

- Hydraulic presses DIN EN 693
- Eccentric and related presses EN 692
- Screw presses EN 692

Type C576



C576

Voltage range		Output contacts			Safety category	Weight (oz.)	Piece per unit	Catalog number	List price
50/60Hz	VDC	Enable contacts		Auxiliary					
		Instantaneous	Time delay						
24VAC	24VDC	2 N.O.	—	—	4	8.47	1	1SAR501120R0001	\$ 350

Description

Emergency Stop switching device and safety door monitor C 576

- Cross-short detection at the EMERGENCY-STOP button or limit switch
- 24 V DC at the EMERGENCY-STOP button
- Single or two-channel connection
- Feedback circuit for monitoring external contactors
- LED indicators for Power, Channel 1, Channel 2 and Power
- Output: 2 NO
- Auto-start
- Overall width: 22.5 mm

Application

The safety relay C576 can be used in safety circuits as per VDE 0113 Part 1 (11.98) or EN 60 204-1 (11.98), i.e., with movable covers and safety gates; the safety relay C577 in Emergency Stop circuits as per EN 418. Depending on external connections, category 4 as per DIN EN 954-1 is achievable.

Type C577



C575

Voltage range		Output contacts			Safety category	Weight (oz.)	Piece per unit	Catalog number	List price
50/60Hz	VDC	Enable contacts	Auxiliary						
		Instantaneous	Time delay						
24VAC	24VDC	2 N.O.	—	—	4	8.47	1	1SAR501220R0001	\$ 350

Description

Emergency stop switching device and safety door monitor C577

- Cross-short detection at the Emergency Stop button or limit switch
- 24 V DC at the Emergency Stop button
- Single or two-channel connection
- Feedback circuit for monitoring external contactors
- LED indicators for Power, Channel 1, Channel 2 and Power
- Output: 2 NO
- Controlled start
- Overall width: 22.5 mm

Application

The safety relay C576 can be used in safety circuits as per VDE 0113 Part 1 (11.98), or EN 60 204-1 (11.98) i.e., with movable covers and safety gates; the safety relay C577 in Emergency Stop circuits as per EN 418. Depending on external connections, category 4 as per DIN EN 954-1 is achievable.

Type C578



C578

Voltage range		Output contacts			Safety category	Weight (oz.)	Piece per unit	Catalog number	List price
50/60Hz	VDC	Enable contacts		Auxiliary					
		Instantaneous	Time delay						
—	24VDC								
24VAC	—	3 N.O.	—	1 N.C.	4	15.87	1	1SAR505031R0003	
110VAC	—							1SAR505031R0002	
230VAC	—							1SAR505031R0004	
	—							1SAR505031R0005	
								\$ 910	

Description

Overtravel monitor C 578

- Cross-short detection at the EMERGENCY-STOP button or limit switch
- 24 V DC at the EMERGENCY-STOP button
- Feedback circuit for monitoring external contactors
- LED indicators for Power and Enable
- Output: 3 NO and 1 NC positively driven
- Controlled start
- Overall width: 45 mm

Application

The overtravel distance tester C578 is intended for checking the overtravel of linearly operating hydraulic, pneumatic and spindle presses in accordance with VBG 7n5.2 §11.

Type C579



C575

Voltage range		Output contacts			Safety category	Weight (oz.)	Piece per unit	Catalog number	List price
50/60Hz	VDC	Enable contacts	Auxiliary						
		Instan- taneous	Time delay						
24VAC 110VAC 230VAC	—	4 N.O.	—	—	—	8.47	1	1SAR502040R0001 1SAR502040R0004 1SAR502040R0003	\$ 390

Description

Expansion unit for contact expansion of the safety switching devices C 579.

One enable contact of the basic device is required for connection to the expansion unit.

- 4 NO positively driven
- Overall width: 22.5 mm

Application

You can use the C579 expansion unit in combination with all the C57x basic units. It extends the number of release circuits. Depending on the external connection, category 4 as per DIN EN 954-1 is achievable with this device.

Accessories for Type C560

Type	Description	Weight (oz.)	Pcs per unit pk	Catalog number	List price
C560.10	Cover cap sealable, for protection against unauthorized adjustment	8.47	5 sets	1SAR390000R1000	\$ 30
C560.20	Panel mounting bracket	8.47	5 sets of two pcs ea.	1SAR390000R2000	22

C565-S

with positively guided contacts

Electronic
Safety relays



1SAR330030R0000



1SAR390000R2000

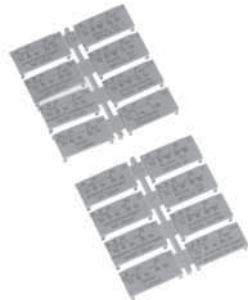

1SAR390000R4000

Terminal positioning C 565-S

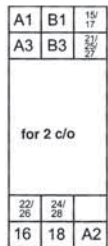

Same voltage must be applied to Terminals A, B.

Circuit diagram C 565-S

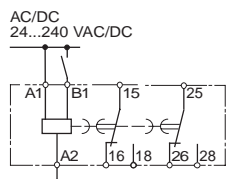

Multifunction time relay – 8 functions^①, 15 time ranges, 2 c/o positively guided & gold plated

Time range with rotary switch can be set to	Supply voltage		Weight (oz.)	Piece per unit	Catalog number	List price
	AC 50/60Hz	DC				
0.05s - 100h ^①	24 - 240V ^②	24 - 240V ^③	5.28	1	1SAR330030R0000	\$ 129.00

Functions can be set by a rotary switch. Separate markers allow a clearly legible and distinctive setting of the timing functions. The markers are available as an accessory.

Accessories

Item description	Ident letter	Piece per unit	Catalog number	List price
C560.10, cover sealable For protecting against unauthorized readjustment	—	5	1SAR390000R1000	\$ 30.00
C560.20, plug-in tab for screw mounting Mounting on panel	—	5 with 2 pieces each	1SAR390000R2000	22.00
C560.40, Set of labels for multifunction relay C565, full set with 16 functions ON-delay OFF-delay, with auxiliary voltage ON and OFF-delay, with auxiliary voltage Flascher, starting with OFF Impulse-ON Impulse-OFF, with auxiliary voltage Pulseformer with auxiliary voltage	A B C D E F G	5 sets	1SAR390000R4000	42.00

- ① Switch position y no timing. To be used for testing purposes (ON/OFF function) within the installation. When voltage is applied the relay remains energized or remains de-energized permanently.
- ② Operating range 0,7 to 1,25 x U_s.
- ③ Operating range 0,85 to 1,1 x U_s.
- ④ The c/o contacts are operated simultaneously, so that 8 functions can be selected (no Ym, no instantaneous contact)
- ⑤ Positively guided: N/C and N/O contacts are never closed both, contact distance of 22.5mm is guaranteed, minimum switching load 12V, 3mA.

Technical data

Time relay		C 565-S
Mechanical service life	operations	30 x 10 ⁶
Rated insulated voltage (Pollution degree 3) Overvoltage categorie III acc. to DIN VDE 0110	AC V	300
Permissible ambient temperature	during operation storage	°C °C
		- 25 to + 60 - 40 to + 80
Operating range of excitation ^①		0.85 to 1.1 x U _s with AC; 0.8 to 1.25 x U _s with DC 0.95 to 1.05 times rated frequency
Rated power at AC 230V, 50 Hz	W VA	2 6
Rated operating currents I _e	AC-15 at AC 230V, 50 Hz AC-140; DC-13 DC-13 at DC 24V DC-13 at DC 48V DC-13 at DC 60V DC-13 at DC 110V DC-13 at DC 230V	A — A A A A A
Output relay		3 ^② — 1 0.45 0.35 0.2 0.1
Fusing DIAZED ^③ [Utilization category gL/gG]	A	4
Switching frequency when loaded with I _e , AC 230V when loaded with contactors B6, B7, AC 230 V	1/h 1/h	2500 5000
Recovery time	ms	150 ^④
Minimum ON period	ms	35
Setting tolerance referred to full scale value	typically ± 5%	
Repeat accuracy		≤ ± 1%
Enclosure acc. to DIN EN 60 529		IP 20 terminals IP 40 covers
Wire size	single-core stranded with wire end ferrule single-core or stranded	mm/in. mm ⁻ AWG
		1 x (0.5 - 4) 2 x (0.5 - 2.5) 1 x (0.5 - 2.5) 2 x (0.5 - 1.5) 2 x (20 - 14)
Terminal screws	for normal screw-driver size 3 and Pozidrive 2	M 3.5
Permissible normal position		any
Resistance to shock semi-sinusoidal acc. to IEC 60068-2-27	g/ms	15/11
Vibro-stability acc. to IEC 60068-2-6	Hz/mm	10-55 / 0,35
EMV-tests by basic specification		EN 50081-1 EN 50082-2

① Unless otherwise specified

② Without any welding as per IEC 60947-5-1.

③ For C565-S; open I_e=1A

④ Wide range voltage power pack; voltage dependent 10 to 250 ms.

C6700 - C6702 with solid state output



Electronic safety relays with solid-state output C 67xx

- Solid-state outputs – no contacts – no wear
- Low weight & small size – Space and weight advantage
- Positively guided standard contactors operate as switching elements

C 67xx safety relays are solely used to monitor the sensors connected (e.g. limit switches resp. EMERGENCY-STOP-buttons) and actuators (positively guided standard contactors).

The basic unit C 6700 itself does not feature safe outputs. Only when the unit is used together with positively guided actuators (e.g. contactors B6, B7) the complete circuit fulfills up to category 3 to EN 954-1.
Us = 24VDC; Ue = 24VDC; Ie = 0.5ADC 13.

The safety relay C 6701 with solid-state outputs can be used directly to switch off connected devices up to category 3 or 4 to EN 954-1. Us = 24VDC; Ue = 24VDC; Ie = 1.5ADC 13.

The safety relay C 6702 with solid-state outputs can also be used to directly switch off connected devices up to category 3 to EN 954-1 and stop categories 0 and 1 at a width of 22.5 mm only.
Time delay settable from 0.05-3 or 0.5-30s. Us = 24VDC; Ue = 24VDC; Ie = 1.5ADC 13.

Type	Supply voltage V_c	Package unit piece	Weight 1 piece kg/lb	Catalog number	List Price
C 6700 C 6701 C 6702 C 6702	24VDC	1	0.150/0.33	1SAR 510 120 R 0003 1SAR 511 320 R 0003 1SAR 543 320 R 0003 1SAR 513 320 R 0003	Consult factory

Technical data

	C 6700	C 6701	C 6702
Permissible ambient temperature T_U Operation / storage Degree of protection acc. to EN 60 529 Rated insulation voltage V_i	-25...+60 °C / -40...+80 °C IP40, IP20 at terminals 50V		
Rated impulse withstand voltage V_{imp} Rated control supply voltage V_S Rated power consumption Operational voltage range Shock resistance (half-sine) acc. to IEC 60068 Weight	500V 24VDC 1.5W 0.9...1.15 x V_S 8g/10ms 150g/0.33lb	2kV 24VDC 1.3W 0.9...1.15 x V_S 8g/10ms 150g/0.33lb	2kV 24VDC 1.3W 0.9...1.15 x V_S 8g/10ms 150g/0.33lb
Recovery time after EMERGENCY STOP Recovery time after power failure Release time after EMERGENCY STOP	min. 20ms — < 30ms	min. 30ms 7 s min. 30ms	min. 30ms — 30ms / 0.05...3s or 0.5...30s adjustable
Recovery time after power failure Response time Response time monitored start Response time Auto-start Short circuit protection	max. 25ms — < 125ms < 250ms no fusing necessary	— max. 40ms — — no fusing necessary	— max. 40ms — — no fusing necessary

Utilization category acc. to IEC 60947-5-1:

		Rated operational voltage V_e	Rated operational current I_e
C 6700	DC-13	24V	0.5A (per output, 60 °C)
C 6701	DC-13	24V	2.0A
C 6702	DC-13	24V	2.0A

- 7
- Solid-state control of actuators, therefore no wear
 - No contact failure at currents of 17V, 1mA
 - Short circuit proof
 - High switching frequencies
 - 24VDC sensor supply
 - Economical

Internal standard circuit diagram of a safe circuit in accordance to C 6700

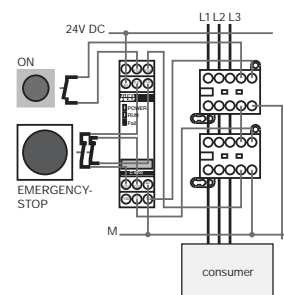

Internal standard circuit diagram of safety relay C 6701 with solid-state output.

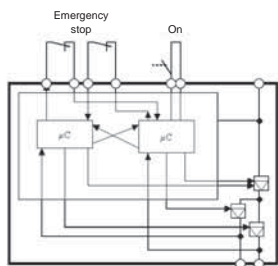

Technical data

C570 - C579

Type	C570	C571	C572	C573	C574	C575	C576	C577	C578	C579
Single-channel connection	x	x	x	x	x	x	x	x	-	x
2-channel connection	-	x	x	x	x	x	x	x	-	x
Cross-short protection	(x) ^①	(x) ^①	x	(x) ^①	x	x	x	x	-	-
Test certificate	BIA, SUVA	BG, SUVA UL, CSA								
Safety category to EN 954-1	2, (3) ^① , (4) ^①	3, (4) ^①	4	3, (4) ^①	4, (3) ^②	4	4	4	4	4
Mechanical service life	3 million operations	10 million operations								
Rated insulation voltage U _i	250 V control circuit	300 V								
Pollution severity 3	400 V output contacts									
Overvoltage category III to DIN VDE 0110										
Rated impulse strength U _{imp}	1.5 kV control circuit	4 kV								
Pollution severity 3	4 kV output contacts									
Permissible ambient temperature for operation	-25 to +55 °C	-25 to +60 °C (suitable for butt-mounting design) -40 to +80 °C								
for storage	-25 to +80 °C									
Enclosure to EN 60 529	IP20	IP20 ^③	IP20	IP20 ^③	IP20	IP20	IP20 ^③	IP20 ^③	IP20	IP20 ^③
Shock-hazard protection to VDE 0106	Safe from finger-touch	Safe from finger-touch								
Rated power DC/AC operation at 1.0 x U _s	6 W	1.5 W	3 W	1.5 W	4 W	3 W	1.5 W	1.5 W	4 W	1.5 W
Operating range AC operation	0.8 to 1.1 x U _s	0.85 to 1.1 x U _s								
DC operation	0.8 to 1.1 x U _s	0.85 to 1.1 x U _s								
Switching frequency	500/h at AC-15 resp. DC-13	1000/h when loaded with I _e								
Resistance to shock	Rectangular shock: 10/5 and 6/10 g/ms Sinusoidal shock: 30/5 and 8/10 g/ms	8 g/10 ms semi-sinusoidal to IEC 60 068								
Short-circuit protection (non-welding fusing at I _k = 1 kA)	Fuse-links for Enable/signalling contacts: l.v.h.b.c., neoZed and diaZed utilization cats. gL/gG quick-acting Fuse supply C570: Cartridge fuse quick-acting/slow-blow, power circuit bkr. A, B, C-characteristic	Fuse-links l.v.h.b.c. Type 3NA, DIAZED Type 5SB, NEOZED Type 5SE6A Utilisation category gL/gG quick-acting								
Wire ranges Flexible with wire end ferrule	2 x (0.5-1.5) mm ² or 1 x (0.5-2.5) mm ²									
Single-core	2 x (0.5-2.5) mm ² or 1 x (0.5-4) mm ²									
Tightening torque, terminal screw M3.5	0.8 to 1.2 Nm									
Electrical service life at I _e		100.000 operations								
Rated operating currents to IEC 60 947-5-1										
Thermal continuous current I _{th} I _e /AC-15	6A	5A								
I _e /DC-13	up to 230 V, 4 A	115 V, 5 A 230 V, 5 A 24 V, 2 A 115 V, 0.2 A 230 V, 0.1 A								
Continuous current		Enable circuits UT 70 °C 4 A 3.5 A 3 A UT 60 °C 4.5 A 4 A 3.5 A UT 50 °C 5 A 4.5 A 4 A								
Mounting positions	any									
Width / mm	75	22.5	45	22.5	45	45	22.5	22.5	45	22.5

① Possible with additional external measures. The figures in bracket apply only if the cables and sensors are laid safely and protected mechanically.

② Applies only to undelayed FK; category 3 applies to time-delayed FK

③ IP 20 terminals, IP 40 housing

Application examples

C6700

Applications

The C 6700 safety combination can be used in EMERGENCY STOP circuits according to EN 418 and in safety circuits according to EN 60 204-1 (11.98), e.g. for moving covers and safety gates. Safety category 3 according to DIN EN 954-1 or SIL2 according to IEC 61508 can be achieved, depending on the external circuits.

Functions and connections

The C 6700 safety relay has two solid-state outputs. Three LEDs indicate the operating state and the function. During operation, all internal circuit elements are cyclically monitored for faults.

The EMERGENCY STOP button or the position switch are connected to terminals Y11, 12 or Y21, 22. The ON button is connected in series to the NC contacts of the external actuators (feedback loop) to terminals Y33, 34 .

The C 6700 safety relay and the activated contactors K1 and K2 must have the same frame potential. Safety category 3 to EN 954-1 is achieved only in combination with 2 external actuators with positively driven feedback contacts.

⚠ Use a power pack to IEC 60536 safety class III (SELV or PELV) for power supply!

Terminal marking

Supply voltage	A1	L/+
	A2	M
Inputs	Y11, 12	Channel 1 EMERGENCY STOP or position switch
	Y21, 22	Channel 2 EMERGENCY STOP or position switch
	Y20	Single channel switch
Outputs	Y33, 34	ON button, feedback loop
	14, 24	Solid-state outputs

Internal circuit

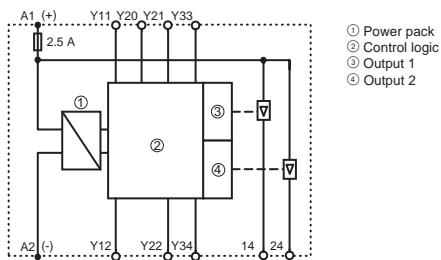

Two channel autostart for safety gate monitoring Category 3/SIL2

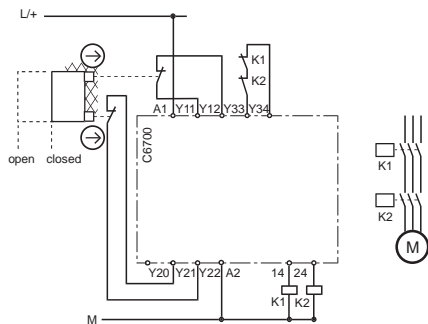

Operation

LEDs			Operation			
POWER	RUN	FAIL	PS	E-STOP	ON	Outputs
☀	☀	●	ON	non activated	activated	on
☀	●	☀		activated	non activated	off
☀	●	●		non activated	non activated	off

Faults

☀	●	☀	<ul style="list-style-type: none"> Defect in electronic Crossover in EMERGENCY STOP circ. 	off
●	●	●	No supply voltage	

Fault clearance

1. Switch supply voltage off.
2. Clear fault or replace device.
3. Switch supply voltage back on.

Cable length

for 2 x 1.5mm² 150nF/km max. 2000m total cable length for sensors

EMERGENCY STOP, single channel, with monitored start Category 3/SIL2

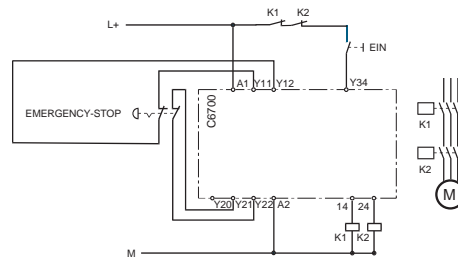

EMERGENCY STOP, single channel, with monitored start Category 2/SIL1

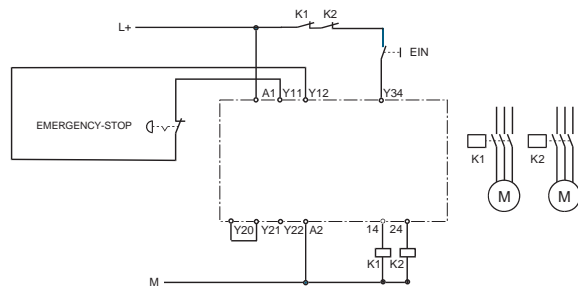

Single channel autostart for safety gate monitoring Category 2/SIL1

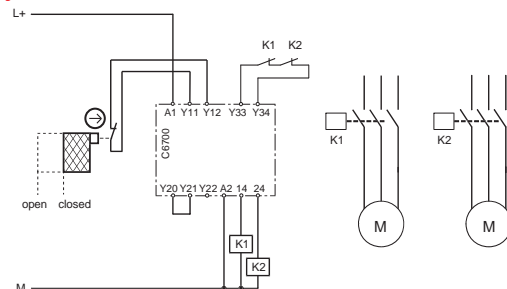

Application examples

C6701

Application

The C 6701 safety combination can be used in EMERGENCY STOP circuits according to EN 418 and in safety circuits according to EN 60 204-1 (11.98), e.g. in movable guards and safety gates. Depending on the external circuit elements, safety category 4 according to DIN EN 954-1 or SIL 3 according to IEC 61508 can be achieved.

Functions and connections

The C 6701 safety combination has two reliable solid-state outputs. Three LEDs indicate the operating state and the function. When the device is put into operation it runs through a self-test to test the correct functioning of the internal electronics. All internal circuit components are monitored for faults cyclically during operation. The EMERGENCY STOP button and/or the position switches or light arrays are connected to terminals Y11, Y12 and Y21, Y22. The ON button is connected in series with the NC contacts of the external actuators to the supply voltage L+ (24 V DC) and to terminal Y34. The cascading input 1 is connected either via a safe output or directly to the supply voltage L+ (24 V DC). External actuators or loads can be switched via safe outputs 14, 24. It must be ensured that the actuators or loads and the C 6701 electronic safety combination have the same frame potential. Paralleling outputs 14 and 24 to increase the load current is not permissible. If electronic sensors (e.g. light-array monitoring) are used, in single-channel operation, Y35 must be connected to L+ (24VDC). For autostart operation, Y32 must be connected directly to L+ (24VDC) and Y34 must be connected to it via NC contacts of the external actuators.

⚠ Use a power pack to IEC 60536 safety class III (SELV or PELV) for power supply!

Terminal marking

Supply voltage	A1	L/+
	A2	M
Inputs	Y11, 12	Channel 1 EMERGENCY STOP or position switch
	Y21, 22	Channel 2 EMERGENCY STOP or position switch
	Y35	With / without cross circuit detection
	Y32	Autostart switch
	Y34	ON button, feedback loop
Input	1	Cascading input
Outputs	14, 24	Safe solid state outputs

Internal circuit

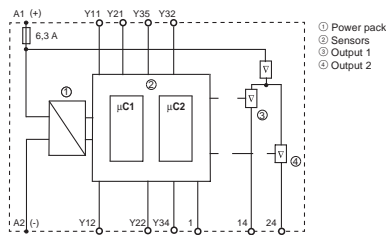

Safety gate monitoring, two channel, autostart Category 4/SIL 3

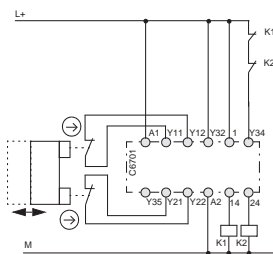

① Sensor circuits open; Cross circuit between the sensors; Short circuit of sensors to frame
 ② Only when using circuit variant with "cross circuit detection".

Operation

LEDs			Operation			
POWER	RUN	FAIL	PS	E-STOP	ON	Outputs
☀	☀	●	ON	non activated	activated	on
☀	●	☀		activated ①	non activated	off
☀	●	●		non activated	non activated	off
☀	●	☾ flashes	on start up self test approx. 7 sec.			
Fault						
☀	●	☾ flashes	Defect in the electronic Change in terminal assignment during operation Short circuit to 24V ②			off
●	●	●	No supply voltage			

Fault clearance

1. Switch supply voltage off.
2. Clear fault or replace device.
3. Switch supply voltage back on.

Cable length

for 2 x 1.5mm² max. 2000m total cable length for 150nF/km sensors

EMERGENCY STOP, single channel, monitored start Category 2/SIL 1

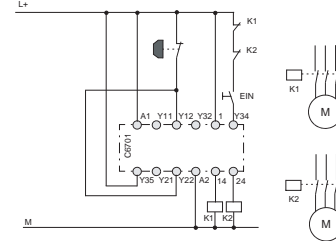

EMERGENCY STOP, two channel, monitored start with additional ON button category — Category 4/SIL3

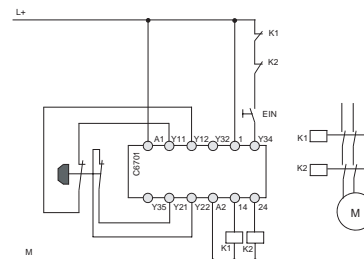

Light array monitoring, two channel, autostart category, Category 4/SIL3

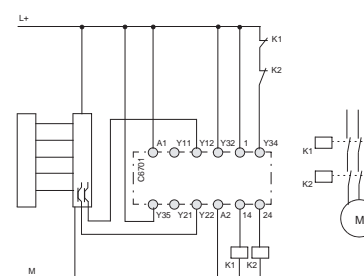

Application examples

C6702

Emergency Stop, two channel, monitored start with additional ON button and safety gate monitoring category 4/SIL 3

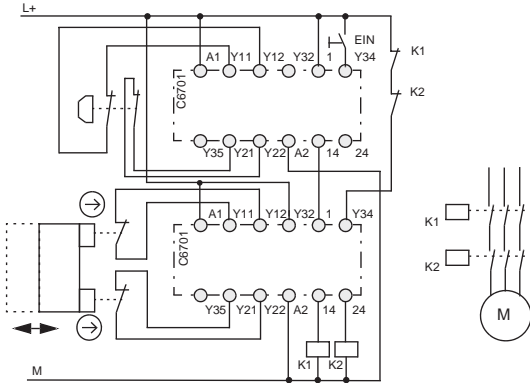

Safety mat, two channel, autostart category 3/SIL 2

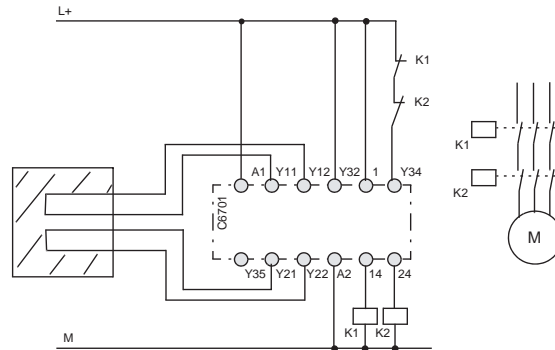

7

Application

The C 6702 safety combination can be used in EMERGENCY STOP circuits according to EN 418 and in safety circuits according to EN 60 204-1 (11.98), e.g. in movable guards and safety gates. Depending on the external circuit elements, safety category 4 according to DIN EN 954-1 or SIL 3 according to IEC 61508 can be achieved.

Functions and connections

The C 6702 solid-state safety combination has one safe solid-state output and one time-delayed safe solid-state output. Three LEDs indicate the operating state and the function. When the device is put into operation it runs through a self-test to test the correct functioning of the internal electronics. All internal circuit components are monitored for faults cyclically during operation. The EMERGENCY STOP button and/or the position switches or light arrays are connected to terminals Y11, Y12 and Y21, Y22. The ON button is connected in series with the NC contacts of the external. The cascading input 1 is connected either via a safe output or directly to the supply voltage L+ (24 V DC). External actuators or loads can be switched via safe outputs 14, 28. It must be ensured that the actuators or loads and the C 6702 electronic safety combination have the same frame potential. Paralleling outputs 14 and 28 to increase the load current is not permissible. If electronic sensors (e.g. light-array monitoring) are used in single-channel operation, Y35 must be connected to L+ (24VDC). For autostart operation, Y32 must be connected directly to L+ (24VDC) and Y34 must be connected to it via NC contacts of the external actuators.

⚠ Use a power pack to IEC 60536 safety class III (SELV or PELV) for power supply!

Terminal marking

Supply voltage	A1	L+
	A2	M
Inputs	Y11, 12	Channel 1 EMERGENCY STOP or position switch
	Y21, 22	Channel 1 EMERGENCY STOP or position switch
	Y35	With / without cross circuit detection
	Y32	Autostart changeover switch
	Y34	ON button, feedback circuit
Input	1	Cascading input
Outputs	14	Safe solid state output
	28	Safe solid state output, time delayed

Operation

LEDs			Operation			
POWER	RUN	FAIL	PS	E-STOP	ON	Outputs
☀	☀	●	ON	non activated	activated	on
☀	●	☀		activated ①	non activated	off
☀	●	●		non activated	non activated	off
☀	☾ flashes	☀		activated	non activated	off/on
☀	●	☾ flashes	on start up self test approx. 7 sec.			
Fault						
☀	●	☾ flashes	Defect in electronic Change in terminal assignment during operation Short circuit to 24V ②			off
●	●	●	No supply voltage			

Fault clearance

1. Switch supply voltage off.
2. Clear fault or replace device.
3. Switch supply voltage back on.

Cable length

for 2 x 1.5mm² 150nF/km max. 2000m total cable length for sensors

Internal circuit

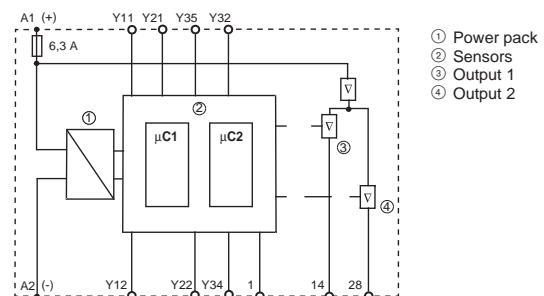

① Sensor circuits open; Cross circuit between the sensors; Short circuit of sensors to frame
② Only when using device with "cross circuit detection".

Application examples C670x

Safety gate monitoring, two-channel, autostart category 4 / SIL 3 with voltage-operated e.i.c.b. and delayed disconnection, stop category 1

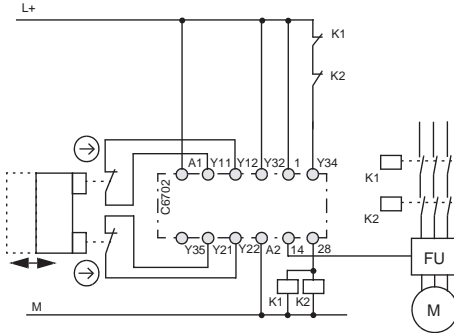

EMERGENCY STOP, single-channel, monitored start with additional ON button category 2 / SIL 1 with voltage-operated e.i.c.b. and delayed disconnection, stop category 1

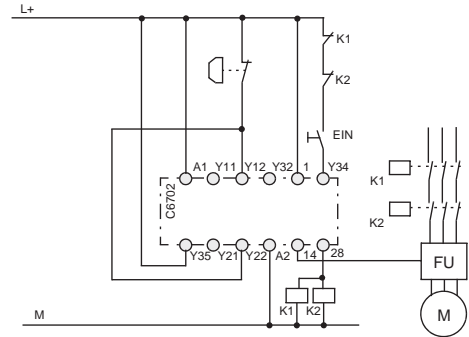

EMERGENCY STOP, two-channel, monitored start with additional ON button category 4 / SIL 3 with voltage-operated e.i.c.b. and delayed disconnection, stop category 1

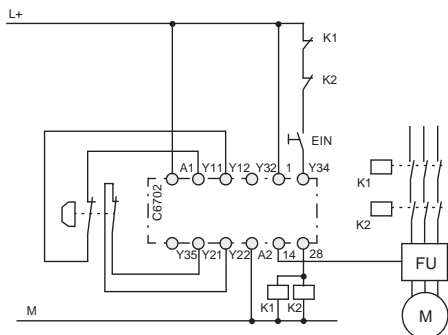

EMERGENCY STOP and safety gate monitoring, two channel with tumbler, monitored start category 4 / SIL 3

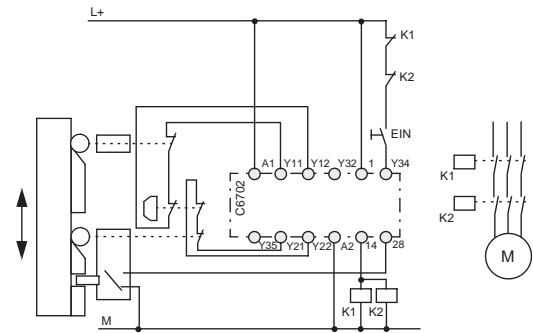

EMERGENCY STOP, two-channel, monitored start with additional ON button and safety gate monitoring, two-channel, autostart; category 4 / SIL 3

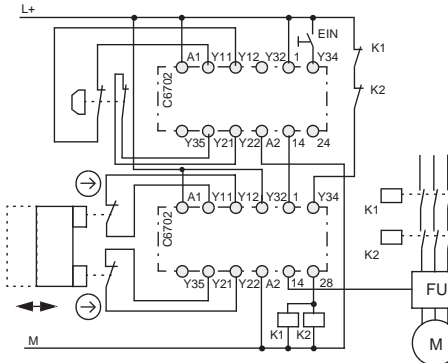

Light-array monitoring, two-channel, autostart category 4 SIL 3

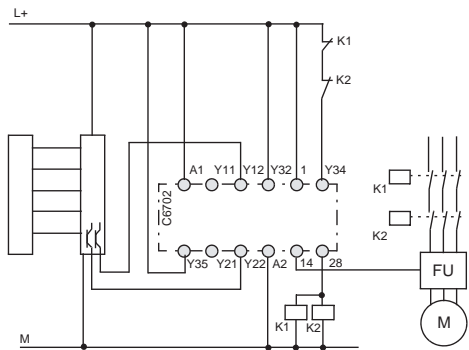

Safety mat, two-channel, autostart; category 3 SIL2

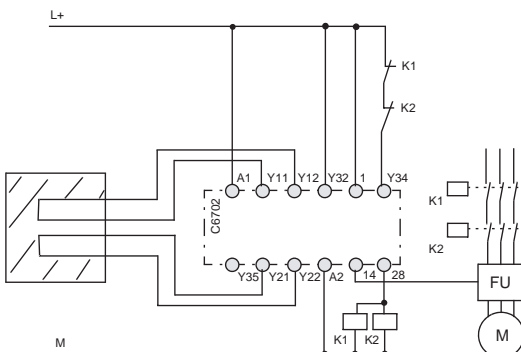

Personnel safety and machine protection

Risk category according to EN 954-1

Classification of a machine into categories to EN 954-1

Pursuant to the Machinery Directive 89/393/EEC, every machine must comply with the relevant directives and standards. Measures must be taken to keep the risk to persons below a tolerable extent.

In the first step, the project planner performs a risk evaluation to EN 1050 "Risk Assessment". This must take into consideration the machine's ambient conditions for instance. Any overall risk must then be assessed. This risk assessment must be conducted in such a form as to allow documentation of the procedure and the results achieved. The risks, dangers and possible technical measures to reduce risks and dangers must be stipulated in this risk assessment. After stipulating the extent of the risk, the category on the basis of which the safety circuits are to be designed is determined with the aid of EN 954-1 "Safety-Related Components of Controls".

This determined category defines the technical requirements applicable to the design of the safety equipment.

7 There are five categories (B, 1, 2, 3 and 4), whereby B (standing for basic category) defines the lowest risk and, thus, also the minimum requirements applicable to the controller.

Possible selection of categories pursuant to EN 954-1

Starting point for the risk assessment of the safety-related component of the controller.

S- Serious injuries

- S1 Slight (normally reversible) injuries,
- S2 Serious (normally irreversible) injuries, including death

F- Frequency and/or duration of the risk exposure

- F1 Rare to frequent and/or short duration of exposure
- F2 Frequent to sustained and/or long duration of exposure

P- Options for risk avoidance

(Generally referred to the speed and frequency at which the dangerous components moves and to the clearance from the dangerous component).

- P1 Possible under certain conditions
- P2 Hardly possible

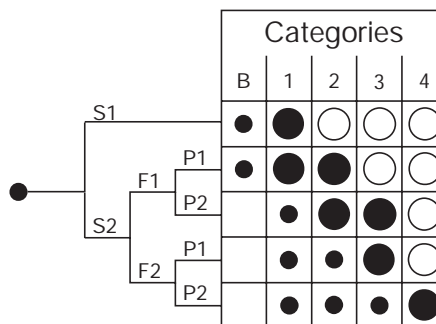

B1-4 Categories for safety-related components of controls

- Preferred category
- Possible category requiring additional measures
- Disproportionately extensive measures by comparison with the risk

Safety category ①	Summary of requirements	System behaviour ②	Principles for achieving safety
B	The safety-related components of controls and/or their protection devices and their components must be designed, constructed, selected, assembled and combined in compliance with the applicable standards, such that they can withstand the anticipated influences.	The occurrence of a fault may lead to loss of the safety function.	Predominantly characterised by selection of components!
1	The requirements of B must be complied with. Time-proven components and time-proven safety principles must be applied.	The occurrence of a fault may lead to loss of the safety function but the probability of occurrence is less than in category B.	
2	The requirements of B and the use of the time-proven safety principles must be complied with. The safety function must be checked at appropriate intervals by the machine control.	<ul style="list-style-type: none"> • The occurrence of a fault may lead to loss of the safety function between the inspection intervals. 	Predominantly characterised by the structure
3	The requirements of B and the use of the time-proven safety principles must be complied with. Safety related components must be designed such that: <ul style="list-style-type: none"> • a single fault in any of these components does not lead to loss of the safety function and • the individual fault is detected, wherever feasible in an appropriate manner. 	<ul style="list-style-type: none"> • The loss of the safety function is detected by the check/inspection. • If the single fault occurs, the safety function is always retained. • Certain faults but not all faults are detected. • An accumulation of undetected faults may lead to loss of the safety function. 	
4	The requirements of B and the use of the time-proven safety principles must be complied with. Safety related components must be designed such that: <ul style="list-style-type: none"> • a single fault in any of these components does not lead to loss of the safety function and • the individual fault is detected at or before the next requirement applicable to the safety function or, if this is not possible an accumulation of faults may then not lead to loss of the safety function. 	<ul style="list-style-type: none"> • If the faults occur, the safety function is always retained. • The faults are detected in good time to prevent loss of the safety function 	

This mandatory classification runs like a red thread from selection of the smallest limit switch through to the overall concept of the entire machine, whereby it is necessary to grapple with the permanent conflict between what is technically feasible and what is permitted on the basis of "pure theory".

Thus: Depending on application, not every technically feasible safety category is also permitted. For instance, in the case of contactless protection devices (light barriers etc.) only categories 2 or 4 are permitted. By contrast, in the case of tread mats, categories B to 4 can be used, depending on risk assessment, provided these categories can be reached at all owing to the design.

The 2-hand control C575 would technically also comply with the lower categories but it cannot be connected in categories 1-3.

① The categories are not intended to be applied in any specific order or hierarchical arrangements with respect to the technical-safety requirements.

② The risk assessment will indicate whether full or partial loss of the safety function(s) as the result of fault is acceptable.

Classification of a machine into categories to EN 954-1

Pursuant to the Machinery Directive 89/393/EEC, every machine must comply with the relevant Directives and Standards. Measures must be taken to keep the risk to persons below a tolerable extent.

In the first step, the project planner performs a risk evaluation to EN 1050 "Risk Assessment". This must take into consideration the machine's ambient conditions for instance. Any overall risk must then be assessed. This risk assessment must be conducted in such a form as to allow documentation of the procedure and the results achieved. The risks, dangers and possible technical measures to reduce risks and dangers must be stipulated in this risk assessment. After stipulating the extent of the risk, the category on the basis of which the safety circuits are to be designed is determined with the aid of EN 954-1 "Safety-Related Components of Controls". This determined category defines the technical requirements applicable to the design of the safety equipment. There are five categories (B, 1, 2, 3 and 4) whereby B (standing for basic category) defines the lowest risk and, thus, also the minimum requirements applicable to the controller.

Possible selection of categories pursuant to EN 954-1

Starting point for risk assessment of the safety-related components of the control.

Description

Scope of application

Potential risks and hazards posed by a machine must be eliminated as quickly as possible in the event of danger.

For dangerous movements, the safe state is generally standstill. All safety switching devices of Series C 570 switch to de-energised state, i.e. standstill for drives, in the event of danger or fault. Standard EN 60204 demands that every machine must feature the Stop function of category 0.

Stop functions of categories 1 and/or 2 must be provided if necessary for technical-safety and/or technical-function requirements of the machine. Category-0 and category-1 stops must be operable independently of the operating mode, and a category-0 stop must have priority.

There are three categories of stop function:

Category 0:

Shut-down by immediate switch-off of the energy supply to the machine drives.

Category 1:

Controlled shut-down, whereby the energy supply to the machine drive is retained in order to achieve shut-down and the energy supply is only interrupted when shut-down has been reached.

Category 2:

A controlled shut-down in which the energy supply to the machine drive is retained.

EMERGENCY-STOP

EMERGENCY-STOP devices must have priority over all other functions. The energy supplied to the machine drives which may cause dangerous states must be switched off as quickly as possible without further risks or dangers. Resetting of the drives may not trigger a restart. The EMERGENCY-STOP must act either as a stop of category 0 or as a stop of category 1.

The basic device of the 570 Series of safety switching devices can be used for EMERGENCY-STOP applications up to maximum category 4 to EN 954-1. Depending on external wiring and cable routing of the sensors, category 3 resp. 4 to EN 954-1 must be reached.

Safety door monitoring

Pursuant to EN 1088, a distinction is made between interlocked, separating protective devices and interlocked, separating protective devices with follower. Here as well, the safety switching devices are used for EMERGENCY-STOP applications. Controls up to category 4 to EN 954-1 are possible.

Presses and punches

The two-hand control C 575 is a device on which the operator must use both hands simultaneously, thus protecting him against risks and dangers.

The overtravel monitor C 578 is used on linear-driven presses (e.g. hydraulic, pneumatic and spindle presses) in accordance with VBG7n52. It checks for the following only once during the test stroke:

- Correct connection of the operating controls
- External cable discontinuity
- Possible failure of the components to be monitored cyclically

The overtravel monitor can be used only in conjunction with a two-hand control. The press controllers and overtravel monitors are suitable for installation in controls for eccentric, hydraulic and spindle presses. They can be used up to category 4 to EN 954-1. Type III C to DIN 574 is possible specifically for presses.

Device construction

The safety switching device C 570 operates internally with several contactor relays. The contacts of the relays comply with the requirement in respect of positively driven operation to ZH 1/457, Edition 2, 1978. This means that NO contact and NC contact may not be closed simultaneously.

Safety relays with positively driven contacts are used in the newly developed safety switching devices C 571-C 574, C 576, C 577, the contact expansion C 579 and on the press controllers C 575 and C 578. This series of devices is characterised by an extremely narrow design (22.5mm and 45 mm). Approvals and test certificates, conventional on the market, have been issued by BG, SUVA, UL and CSA.

The function of the internal contactor relays/relays is monitored in a redundant circuit. In the event of failure of a relay, the safety switching device always switches to de-energised state. The fault is detected and the safety switching device can no longer be switched on. Using normally closed contacts and normally open contacts for the same function complies with the requirement in respect of diversity.

Enable contacts (FK)

The safety-related function must be controlled via safe output contacts, the so-called Enable contacts. Enable contacts are always normally open contacts and switch off without delay.

Signalling contacts (MK)

Normally open contacts and normally closed contacts which may not perform safety-related functions are used as the signalling contact.

An Enable contact may also be used as a signalling contact.

Delayed Enable contacts

Drives which have a long overtravel must be decelerated in the event of danger. For this purpose, the energy supply must be maintained for electrical braking (stop category 1 to EN 60 204-1). The safety switching device C 574 also feature OFF-delayed Enable contacts, besides undelayed Enable contacts. Delay times of 0.5 to 30 s are available.

The sealable cover cap C 560.10 (see Selection data and Ordering details, Accessories) can be fitted onto C 574, C 6702 to protect against unauthorised adjustment of the set delay time.

Contact expansion

If the Enable contacts of the basic device do not suffice, positively driven contactors (e.g. B6, B7) may be used for contact expansion. One solution for increasing the number of Enable contacts, which is both simple to use and space-saving, is the expansion unit C 579 (only 22.5mm wide). The expansion unit C 579 provides 4 additional Enable contacts.

Expansion unit C 579

Expansion unit C 579 may not be operated separately in safety-related circuits but must be combined with a safety switching device C 57x. One Enable contact of the basic device is required for connection of an expansion unit. The category of a control with expansion units corresponds to the category of the basic device.

Mounting

Snap-on mounting on 35mm top-hat rail to EN 50 022. Screw mounting of the safety switching devices C 57x can be implemented with two additional plug-in tabs C 560.20 (see Selection data and Ordering details, Accessories).

User Manual

A User Manual with a device description, connection diagrams and application information in several languages is enclosed with every safety switching devices of Series C 570 and C 67xx.

"Safety Engineering" Application Manual

You can find further information in the "Safety Engineering" Application Manual. It provides you with the required information on the relevant safety standards and project planning information.

The entire range of components used for safety applications is explained in this Manual, from the sensor (Emergency-Stop command devices and position switches), through evaluation units (safety switching devices C 57x and fail-safe control

AC 31 S) to the actuator (e.g. contactor for switching motors). All these components must be selected correctly in order to meet the requirements applicable to modern safety facilities.

Please order the "Safety Engineering" Application Manual

1SAC 103 201 H 0101 German

1SAC 103 201 H 0201 English

Selection guide C570 – C6702

Selection table for ABB safety relays in accordance to risk category (EN 954-1):

Category	C 570	C 571	C 572	C 573	C 574	C 575	C 576	C 577	C 578	C 6700	C 6701	C 6702
B												
1	x	x	x	x	x		x	x		x	x	x
2	x	x	x	x	x		x	x		x	x	x
3	x ^①	x	x	x	x		x	x		x	x	x
4		x ^①	x	x ^①	x ^②	x	x	x	x		x	x

Selection table for ABB safety relays in accordance to device characteristics

Characteristics suitable for device	C 570	C 571	C 572	C 573	C 574	C 575	C 576	C 577	C 578	C 579	C 6700	C 6701	C 6702
7 EMERGENCY STOP	yes	yes	yes	yes	yes	—	yes	yes	—	③	yes	yes	yes
Safety gate monitoring	yes	yes	yes	yes	yes	—	yes	yes	—	③	yes	yes	yes
Tread mats	—	—	—	—	—	—	—	—	—	—	—	—	-
Two-hand control e.g. presses	—	—	—	—	—	yes	—	—	—	—	—	—	-
Feedback loop for monitoring of external contactors	yes	yes	yes	yes	yes	yes	yes	yes	—	—	yes	yes	yes
Single channel	yes	yes	yes	yes	yes	—	—	—	—	—	yes	yes	yes
Two channel	—	yes	yes	yes	—	yes	yes	yes	—	—	yes	yes	yes
Cross-short circuit monitoring	—	—	yes	—	yes	—	yes	yes	—	—	—	yes	yes
24VDC at the EMERGENCY STOP limit switch	—	—	yes	—	—	yes	yes	yes	yes	—	yes	yes	yes
Operating voltage at the EMERG. STOP limit switch	yes	yes	—	yes	yes	—	—	—	—	—	—	—	-
No. of safety outputs	4	2	3	3	2	2	2	2	—	4	2 ^④	2	1
No. of time delayed safety output contacts	—	—	—	—	1	—	—	—	—	—	—	—	1
No. of signalling contacts	2	—	2	1	2	2	—	—	—	—	—	— ^⑤	— ^⑤
Enclosure width in mm	75	22.5	45	22.5	45	45	22.5	22.5	45	22.5	22.5	22.5	22.5
Monitoring overtravel e.g. presses	—	—	—	—	—	—	—	—	yes	—	—	—	—
Auto-start	yes	yes	yes	yes	yes	—	yes	—	—	—	yes	yes	yes
Controlled/monitored start	—	—	yes	—	—	—	—	yes	—	—	yes	yes	yes

① Possible with additional external measures.

② Applies only to undelayed contact. Category 3 applies to delayed contact.

③ Contact extension

④ Solid-state outputs requirements of safety in acc. to 954-1 only in combination with positively guided contactors.

⑤ Solid-state outputs could also be used as safe messaging outputs.

Application examples

C570, C571, C573

Information

The safety relays are tested by BIA. The shown external wiring diagrams / application examples are examples of use only. A risk appraisal has to be done by the user. Further application examples on request.

C570 Application

The safety relay can be used to monitor EMERGENCY STOP circuits and for monitoring of other protective devices (e.g. safety gates)

EMERGENCY-STOP circuit

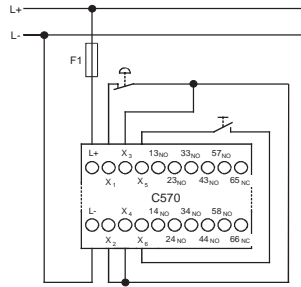

Operation

Operating states indication:

"READY" indicates that the supply voltage is applied to the unit, provided that the contacts of the EMERGENCY STOP pushbutton or door safety switch are closed. "ON" lights up, when the ON button is pressed and the enabling circuits are switched through.

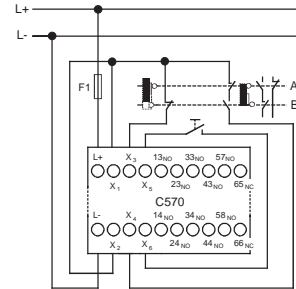

Safety gate monitoring
(A= door open,
B= door closed)

7

C571, C573 Application

The safety relays C 571/C 573 can be used in EMERGENCY STOP circuits as per EN 418 and in safety circuits as per VDE 0113 Part 1 (11.98) and/or EN 60 204-1 (11.98), e.g. with movable covers and guard doors. Depending on the external connections, categories 3 and 4 (with additional external measures) as per DIN EN 954-1 are achievable.

Functions and connection

The safety relay C 573 has three release circuits (safety outputs) which are configured as NO contacts and a signal circuit configured as a NC contact. The safety relay C 571 has two release (safe) circuits which are configured as NO contacts. The number of release circuits can be increased by adding one or more C 579 extension units. Three LEDs indicate the operating state and function. When the EMERGENCY STOP button or the limit switch is unlocked and when the ON button is pressed, the internal circuits of the safety relays and the external contactors are checked for proper functioning. Connect the EMERGENCY STOP pushbutton or the limit switch in the supply cable from A1 to +24 or L24 V. To evaluate over two channels, connect Channel 2 from A2 to 0 V or N. Connect the ON button in series with the NC contacts of the external contactor (feedback loop) between terminals Y1 and Y2.

Terminal markings

Supply voltage	A1 A2	L/+ N/-
Sensors	Y1, Y2	ON button, feedback loop
Outputs	13, 14 23, 24 33, 34 41, 42	Safety output 1 (n/o) Safety output 2 (n/o) Safety output 3 (n/o)* Signal circuit 1 (n/c)*

* with C 573 only

Operating states

LEDs	Channel		Operation			
	Channel 1	Channel 2	PS	EMERG. STOP	ON	Safety output
☀	☀	☀	ON	non activated	activated	closed
☀	●	●		activated	non activated	open
☀	●	●		non activated	non activated	open
Faults						
☀	☀	●	Relay fusion-welded			open
☀	●	☀	Motor contactor fusion-welded			
☀	●	●	Defects in electronic			
●	●	●	Cross or ground faults in EMERG. STOP circuit (min. fault current $I_{kmin} = 0.5A$; PTC-fuse trips or supply voltage missing)			

Fault clearance

1. Switch supply voltage off.
2. Clear fault or replace device.
3. Switch supply voltage back on.

Cable length

for 2 x 1.5mm² max. 1000m (total cable length for 150 nF/km sensors and power supply lines)

Internal circuit

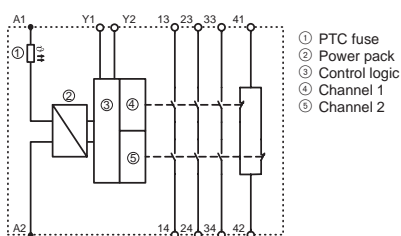

Emergency Stop, category 2 acc. to EN 954-1

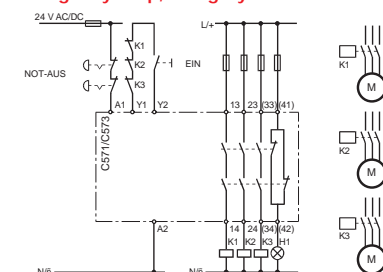

EMERGENCY STOP, category 3 and 4 acc. to EN 954-1

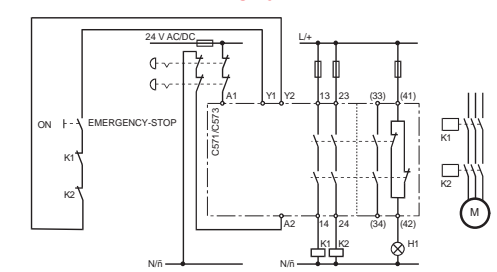

Application examples C571-AC

Safety gate monitoring, category 2 acc. to EN 954-1

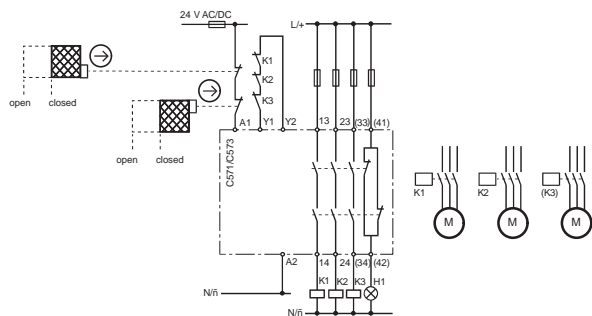

Safety gate monitoring, category 3 and 4 acc. to EN 954-1

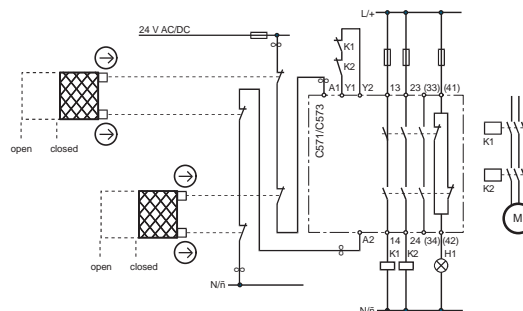

7 Application

The safety relay C 571-AC can be used in EMERGENCY STOP circuits as per EN 418 and in safety circuits as per VDE 0113 Part 1 (11.98) and/or EN 60 204-1 (12.97), e.g. with movable covers and safety gates. Depending on the external connections, safety categories 3 and 4 as per DIN EN 954-1 are achievable. When the safety combination is used in «automatic start» mode, automatic re-starting (as per EN 60 204-1, sections 9.2.5.4.2 and 10.8.3) must be prevented by the higher-level control system in the event of EMERGENCY STOP.

Functions and connections

The safety relay C 571-AC has two release circuits (safety outputs) which are configured as NO contacts. The number of safety outputs can be increased by adding one or more C 579 extension modules. Three LEDs indicate the operating state and function.

When the EMERGENCY STOP button or the limit switch is unlocked and when the ON button is pressed, the internal circuits of the safety relay and the external contactors are checked for proper functioning.

Connect the EMERGENCY STOP button or the limit switch to terminals Y11, 12 and Y21, 22. The ON button is connected in series with the NC contacts of the external contactor (feedback loop) between terminals Y33, 34.

Terminal marking

Supply voltage	A1	L
	A2	N
Sensors	Y11, 12	Channel 1 EMERGENCY STOP or limit switch
	Y21, 22	Channel 2 EMERGENCY STOP or limit switch
	Y33, 34	ON button, feedback loop
Outputs	13, 14	Safety output 1 (n/o)
	23, 24	Safety output 2 (n/o)

Internal circuit

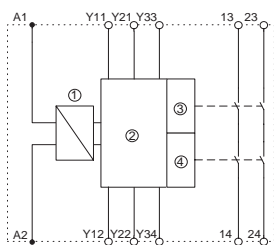

- ① Power pole
- ② Control logic
- ③ Channel 1
- ④ Channel 2

Two channel autostart for contactor monitoring; Safety category 3 and 4 acc. to EN 954-1

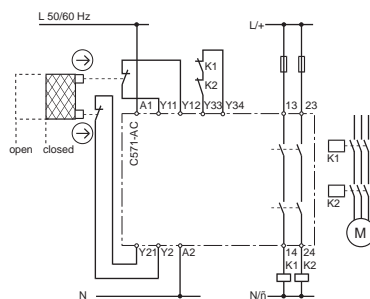

Operating states

LEDs			Operation			
POWER	Channel 1	Channel 2	PS	E-STOP	ON	Safety output
☀	☀	☀	ON	non activated	activated	closed
☀	●	●		activated	non activated	open
☀	●	●		non activated	non activated	open
Faults						
☀	☀	●	Relay fusion-welded Motor cont.fusion-welded Defects in electronic			open
●	●	●	Cross or ground faults in EMERG. STOP circuit			

Fault clearance

1. Switch supply voltage off.
2. Clear fault or replace device.
3. Switch supply voltage back on.

Cable length

for 2 x 1.5mm² max. 1000m (total cable length for 150 nF/km sensors and power supply lines)

Single-channel EMERGENCY STOP with additional ON button Safety category 2 acc. to EN 954-1

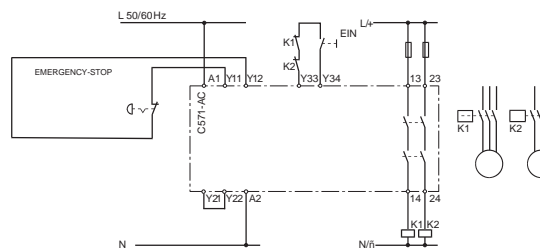

Two-channel EMERGENCY STOP with additional ON button Safety category 3 and 4 acc. to EN 954-1

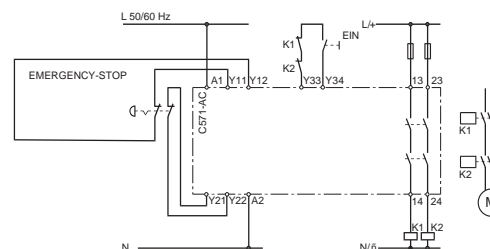

Application examples C572

Application

The safety relay C 572 can be used in EMERGENCY STOP circuits as per EN 418, in safety circuits as per VDE 0113 Part 1 (06.93) and/or EN 60 204-1 (12.97), e.g. with movable covers and safety gates. Depending on the external connection, safety category 4 as per DIN EN 945-1 is achievable with this device.

Functions and connections

The safety relay C 572 has three release circuits (safety outputs) which are configured as NO contacts and two signal circuits configured as an NC contact. Three LEDs indicate operating state and function. When the EMERGENCY STOP pushbutton or limit pushbutton is unlocked and the ON pushbutton is pressed, the redundant safety relays, electronic circuitry and external contactors are tested for proper functioning. On the C 572, the ON circuit Y33, 34 is checked for short circuit. This means that a fault is detected when Y33,34 is closed before the EMERGENCY STOP button is closed.

Terminal marking

Supply voltage	A1 A2	L/+ N/-
Outputs	13, 14 23, 24 33, 34 41, 42 51, 52	Safety output 1 (n/o) Safety output 2 (n/o) Safety output 3 (n/o) Signal output 1 (n/c) Signal output 2 (n/c)

Function	Monitored start	Monitored start / Autostart	Autostart
1-channel	ON push button at Y33, 34	Jumper from Y11 to Y12 Jumper from Y21 to Y22 EMERGENCY-STOP circuits at Y10, 11	Feedback loop or jumper to Y33, 34 and jumper from
2-channel		Jumper from Y10 to Y11 EMERGENCY-STOP circuits at Y11, 12 and Y21, 22	Y43 auf Y44 Important: Y21, 22 must be closed before or at the same time as Y11, 12

Internal circuit

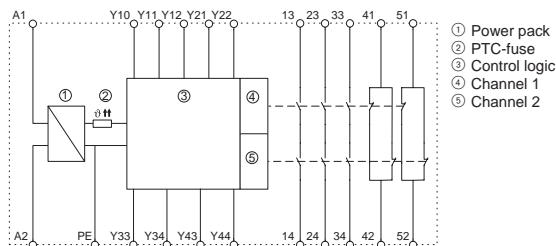

Autostart for guard door monitoring; Safety category 2 acc. to EN 954-1

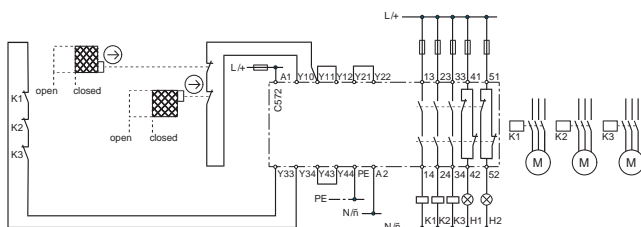

Operation states

LEDs			Operation			
POWER	Channel 1	Channel 2	PS	E-STOP	ON	Safety outputs
☀	☀	☀	ON	non activated	activated	closed
☀	●	●		activated	non activated	open
☀	●	●		non activated	non activated	open
Faults						
☀	☀	●	Relay fusion-welded			open
☀	●	☀	Motor cont.fusion-welded			
☀	●	●	Defects in electronic Short circuit in ON circuit			
●	●	●	Cross or ground faults in EMERG. STOP circuit (min. fault current $I_{Kmin} = 0.5A$; PTC-fuse trips or supply voltage missing)			

Fault clearance

1. Switch supply voltage off.
2. Clear fault or replace device.
3. Switch supply voltage back on.

Cable length

for 2 x 1.5mm² max. 1000m (total cable length for 150 nF/km sensors and power supply lines)

Autostart and safety gate monitoring

Safety category 4 acc. to EN 954-1

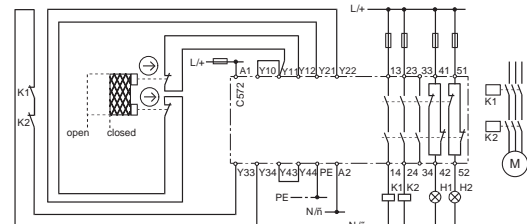

Monitored start for EMERGENCY STOP

Safety category 2 acc. to EN 954-1

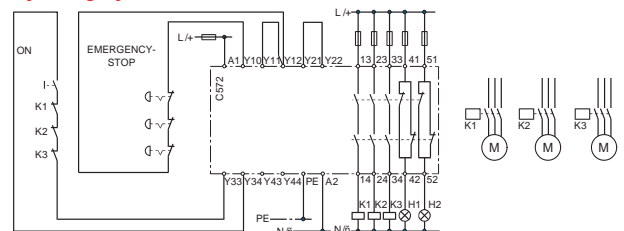

Monitored start for EMERGENCY STOP

Safety category 3 and 4 acc. to EN 954-1

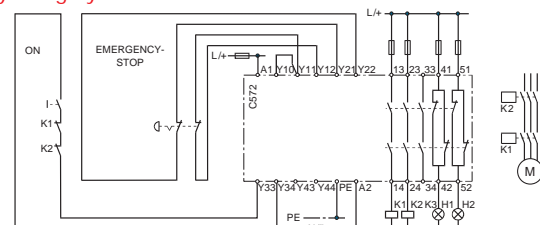

Application

The safety relay C 574 can be used in EMERGENCY STOP devices as per EN 418, in safety circuits as per VDE 0113 Part 1 (06.93) and/or EN 60 204-1 (12.97), such as for monitoring safety gates, or in circuits with controlled stand-still requirement (STOP Category 1). Depending on the external circuitry, this device can be used to realize Safety Category 4 instantaneous release circuits and Safety Category 3 delayed release circuits according to DIN EN 954-1.

Functions and connections

The C 574 safety relay possesses two delayed and two instantaneous release circuits (safety outputs) as NO contacts and one instantaneous signal output as NC contact. Five LEDs indicate the operating status and the functions.

The redundant safety relays, the electronics and the operated motor contactors are tested for proper functioning when the EMERGENCY STOP button or the limit switch button is unlatched, and when ON circuit Y33, Y34 is closed.

On the C 574 (monitored start), the ON circuit Y33, 34 is checked for short circuit. This means that a fault is detected when Y33, 34 is closed before the EMERGENCY STOP button is closed.

Terminal marking

Supply voltage	A1 A2	L/+ N/-
Output	13, 14 23, 24 31, 32 47, 48 57, 58	Safety output 1, instantaneous Safety output 2, instantaneous Signal output, instantaneous Safety output 1, delayed (t) Safety output 2, delayed (t)

Function Monitored Start

1-channel	ON pushbutton at Y33, 34	Jumper from Y11 to Y12 Jumper from Y21 to Y22 EMERGENCY STOP circuits at Y10, 11
2-channel		Jumper from Y10 to Y11 EMERGENCY STOP circuits at Y11, 12 and Y21, 22

Internal circuit

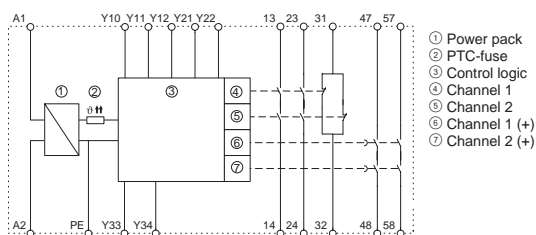

Monitored start for EMERGENCY STOP

Safety category 3 and 4 acc. to EN 954-1

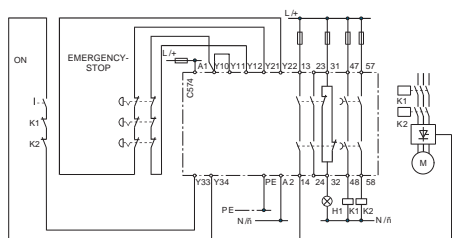

Operation

LEDs					Operation			
POWER	Ch 1	Ch 2	Ch 1	Ch 2	PS	E-STOP	ON	Safety outputs
☀	☀	☀	☀	☀	ON	non activated	activated	closed
☀	●	●	●	●		activated delay time elapsed	non activated	open
☀	●	●	●	●		non activated	non activated	open
☀	●	●	☀	☀		activated delay time elapsed	non activated	FK 1 & 2 open, FK1(t) & FK2(t) closed
					Faults			
☀	☀	●	☀	●		Relay fusion-welded		open
☀	●	☀	●	☀		Motor cont. fusion-welded		
☀	●	●	●	●		Defect in electronic Short circuit in ON circuit		
●	●	●	●	●		Cross or ground faults in emergency trip circuit (min. fault current $I_{kmin} = 0.5A$; PTC fuse trips)		

Fault clearance

1. Switch supply voltage off.
2. Clear fault or replace device.
3. Switch supply voltage back on.

Cable length

for 2 x 1.5 mm² 150nF/km max. 1000m total cable length for sensors and power supply lines)

Monitored start for EMERGENCY STOP

Safety category 2 acc. to EN 954-1

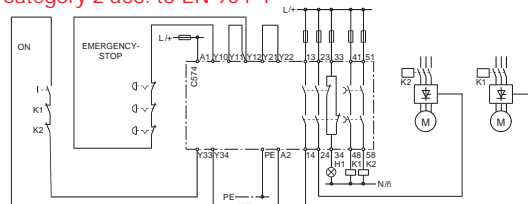

Safety gate monitoring

Safety category 3 and 4 acc. to EN 954-1

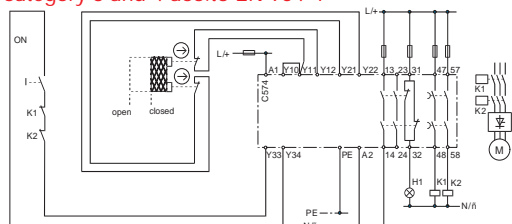

Safety gate monitoring

Safety category 2 acc. to EN 954-1

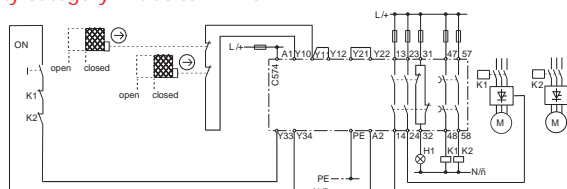

Application examples

C575

Application

C 575 is suitable for installation in controls for presses.

- Hydraulic presses DIN EN 693,
- Eccentric and related presses EN 692,
- Screw presses EN 692.

Functions and connections

The two-hand control unit C 575 possesses two release circuits (safety outputs) configure as NO contacts and two signal outputs configured as NC contacts. Five LEDs indicate the operating status and the functions.

The safety outputs are closed by simultaneous operation (< 0.5s) of the push-buttons S1, S2. If one pushbutton is no longer pressed, the outputs open. They do not close again until both pushbuttons are no longer pressed and then simultaneously pressed again.

1. Operating voltage to be applied to the terminals A1 and A2.
The operating voltage must be de-energized with the operating energy of the press.
2. Feedback loop to be closed:
Y11, Y12 to be jumperd or connected to the NC contacts of external contactors.
3. Input circuits to be connected:
Pushbutton S1 to terminals Y21, Y22, Y23 and
pushbutton S2 to terminals Y31, Y32, Y33.

Terminal marking

Supply voltage	A1	L/+
	A2	N/-
Outputs	13, 14	Safety output 1 (n/o contact)
	23, 24	Safety output 2 (n/o contact)
	31, 32	n/c signal output
	41, 42	n/c signal output
Inputs	Y11, Y12	Feedback loop
	Y21, 22, 23	Pushbutton S1
	Y31, 32, 33	Pushbutton S2

Internal circuit

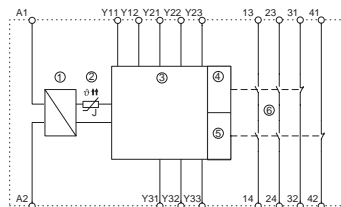

Operation

LEDs					Operation
POWER	S1 ON	S2 ON	Channel 1	Channel 2	
☀	●	●	●	●	Pushbutton non activated
☀	☀	●	●	●	only S1 activated
☀	●	☀	●	●	only S2 activated
☀	☀	☀	☀	☀	S1 and S2 activated

The unit cannot be started with the following faults:

- Short circuit, e.g. between the pushbuttons
- Defective relay coils
- Conductor failure
- Welded contacts

The output relays does not energize if:

- The pushbuttons are not pressed simultaneously (< 0.5s)
- Only one pushbutton is pressed
- The feedback loop Y11, Y12 is open.

Cable length

max. 1000m for 2 x 1.5mm² (Total cable length for sensors and power supply lines)

External circuit S1, S2 pushbuttons on two-hand control console, H1 indicator light, K1 and K2 must be positively guided contactors, Safety category 4 acc.to EN 954-1

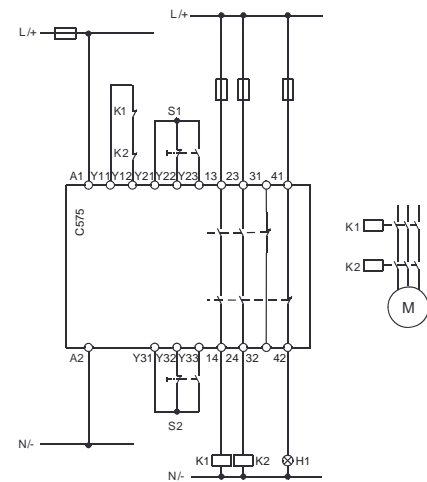

Application examples C576, C577

Application

The safety relay C 576 can be used in safety circuits as per VDE 0113 Part 1 (11.98) or EN 60 204-1 (11.98), e.g. with movable covers and safety gates; the safety relay C 577 in EMERGENCY STOP circuits as per EN 418. Depending on external connections, category 4 as per DIN EN 954-1 is achievable.

Functions and connections

The safety relays C 576/C 577 have two release circuits (safety outputs) configured as NO contacts. The number of release circuits can be increased by adding one or more C 579 extension units.

Three LEDs indicate operating state and function.

When the EMERGENCY STOP button or the limit switch is unlocked and when the ON button is pressed, the internal circuit of the safety relay and the external contactors are checked for proper functioning.

On the C 577, the ON circuit Y33, 34 is checked for short circuit.

This means that a fault is detected when Y33, 34 is closed before the EMERGENCY STOP button is closed.

The EMERGENCY STOP button or the limit switch are connected to terminals Y11, 12, 21, 22. The ON button is connected in series to the NC contacts of the external contactors (feedback loop) to terminals Y33, 34.

Terminal marking

Supply voltage	A1 A2	L/+ N/-
Sensors	Y11, 12 Y21, 22	Channel 1 EMERGENCY STOP or limit switch Channel 2 EMERGENCY STOP or limit switch
Outputs	Y33, 34 13, 14 23, 24	ON button, feedback loop Safety output 1 (n/o contact) Safety output 2 (n/o contact)

Fault clearance

1. Switch supply voltage off.
2. Clear fault or replace device.
3. Switch supply voltage back on.

Cable length

for 2 x 1.5mm² max. 1000m total cable length for
150nF/km sensors and power supply lines)

Internal circuit

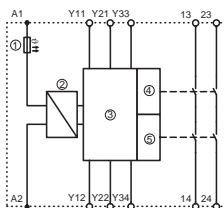

Operation

LEDs			Operation			
POWER	Channel 1	Channel 2	PS	E-Stop	ON	Safety outputs
☀	☀	☀	ON	non activated	activated	closed
☀	●	●		activated	non activated	open
☀	●	●		non activated	non activated	open
Faults						
☀	☀	●	Relay fusion-welded Motor cont. fusion-welded			open
☀	●	☀	Defect in electronic Short circuit in ON circuit			
☀	●	●	Cross or ground faults in EMERGENCY STOP circuit (min. fault current $I_{Kmin} = 0.5A$; PTC fuse trips)			

C 577 with monitored start for EMERGENCY STOP Category 4 acc. to EN 954-1

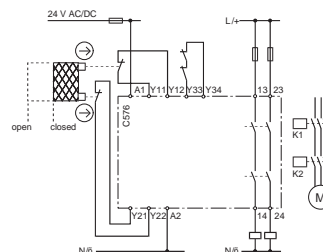

C 577 with monitored start for EMERGENCY STOP Category 4 acc. to EN 954-1

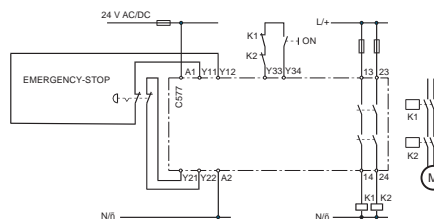

Application examples

C578

Application

The overtravel distance tester C 578 is intended for checking the overtravel of linearly operating hydraulic, pneumatic and spindle presses in accordance with VBG 7n5.2 §11.

Functions and connections

The overtravel distance tester C 578 has four safety outputs, three NO contacts and one NC contact. Two LEDs indicate the functions.

The C 578 tests the overtravel distance in connection with a position switch every time the control voltage is switched on. The permissible overtravel distance corresponds to dimension 's' of the cam that is used to operate the position switch. Obtain dimension 's' from the press manufacturer in accordance with ZH 1/456 (published by the German central office for accident prevention and labour safety, Cologne).

Terminal marking

Supply voltage	A1 A2	L/+ N/-
Outputs	13, 14 23, 24 33, 34 41, 42	Safety output 1 (tool down) n/o contact (tool up) n/o contact (overtravel distance OK) n/c contact (hydraulic pump ON)
Inputs	Y11, 12, 13, 14 Y21, 22 Y31, 32, 33, 34	Feedback loop (K4) Position switch (S4) Top dead centre switch (S3)

External circuit

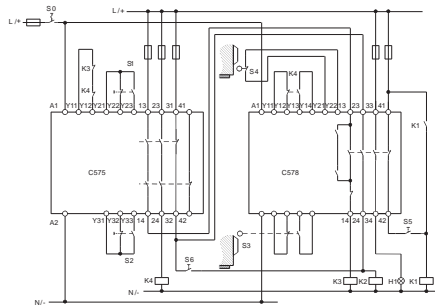

C 575 two hand control unit,
S0 Main switch,
S1, S2 keys at two hand control console,
S3 Position switch for top dead centre,
S4 Position switch for test cam
S5 Hydraulic pump "ON",
S6 Tool "up" (manual mode),
K1 Contactor for hydr. pump,
K2 Tool "up",
K3, K4 Tool "down",
H1 Indicator light

Operation

Sequence of operations after the press has been switched on:

1. Switch on the hydraulic pump with S5, move plunger to top dead centre, if necessary by means of S6.
2. Operate S1, S2 on the two-hand control console until the position switch for test-cam (S4) opens.
3. Stop operating S1, S2.
4. Operate S1, S2 again: Indicator light H1 lights up if the overtravel distance is OK.
5. Stop operating S1, S2: The plunger returns to top dead centre.
6. If overtravel distance is OK, all outputs remain active until the control voltage is switched OFF.

LEDs		Operation
POWER	Release	
		Overtravel distance OK.
		Overtravel distance incorrect or test not yet performed

Fault

If the cam overtravels position switch S4, indicator light H1 does not light up. The hazardous part of the machine can be moved up to top dead centre only by means of S6.

The press can no longer be used for production. When this happens, notify the maintenance staff that the press needs attention.

Internal circuit

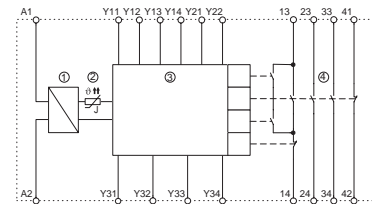

Application examples C579

Applications

You can use the C 579 expansion unit in combination with all the C 57x basic units. It extends the number of release circuits. Depending on the external connection, category 4 as per DIN EN 954-1 is achievable with this device.

Functions and connections

The C 579 expansion unit has four release circuits (safety circuits) configured as NO circuits.

Two LEDs indicate operating state and function. The device is controlled via any release circuit of the safety relays C 57x.

When the EMERGENCY STOP pushbutton or the limit switch is unlocked and the ON button is pressed, the internal circuit of the safety relay and the external contactors are checked for correct functioning.

7 Terminal marking

Supply voltage	A1 A2	L/+ N/-
Outputs	13, 14 23, 24 33, 34 43, 44	Safety output 1 (n/o contact) Safety output 2 (n/o contact) Safety output 3 (n/o contact) Safety output 4 (n/o contact)
Feedback loop	51, 52	Monitoring of the extension unit

Internal circuit

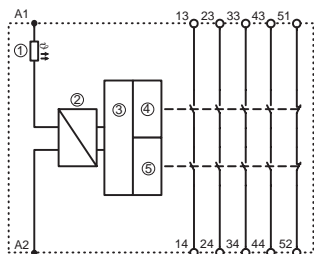

EMERGENCY STOP

Safety category 4 acc. to EN 954-1

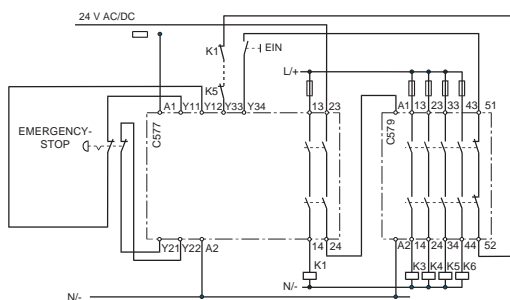

Operation

LEDs		Operation	
Channel 1	Channel 2	PS	Safety output of C 57x safety relays
		ON	closed
			open
		Faults	
		Relay fusion-welded	
		Defect in electronics	
		Motor contactor fusion welded	

Fault clearance

1. Switch supply voltage off.
2. Clear fault or replace device.
3. Switch supply voltage back on.

Cable length

For 2 x 1.5mm² max. 1000m total cable length for 150nF/km sensors and power supply lines.

Safety gate monitoring

Safety category 4 acc. to EN 954-1

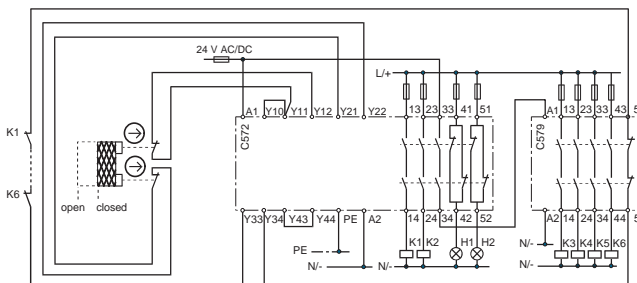

EMERGENCY STOP with time delay

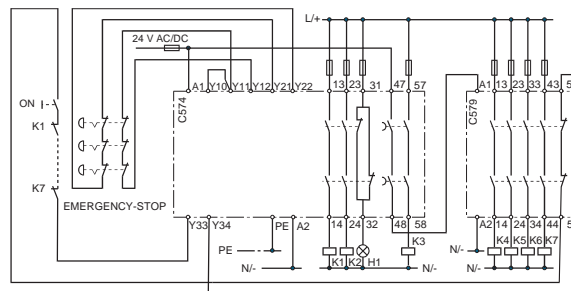

Approximate dimensions

C570

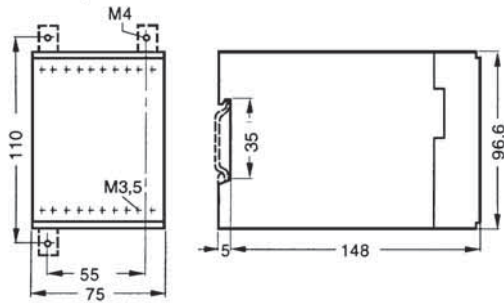

C571, C573, C576, C577, C579

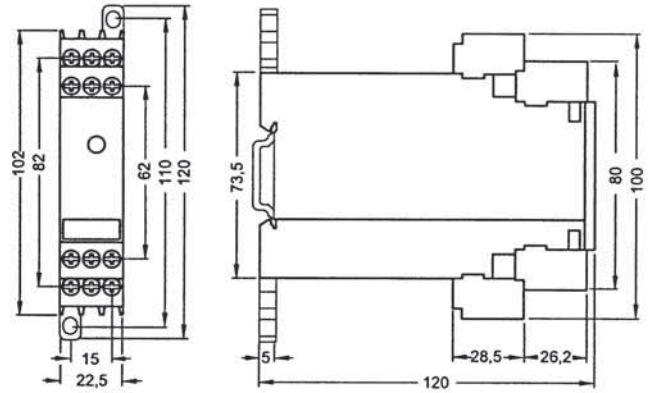

C572, C574, C575, C578

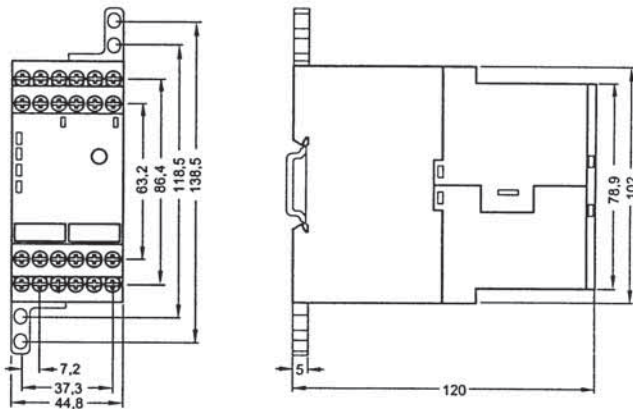

C6700 / C6701 / C6702

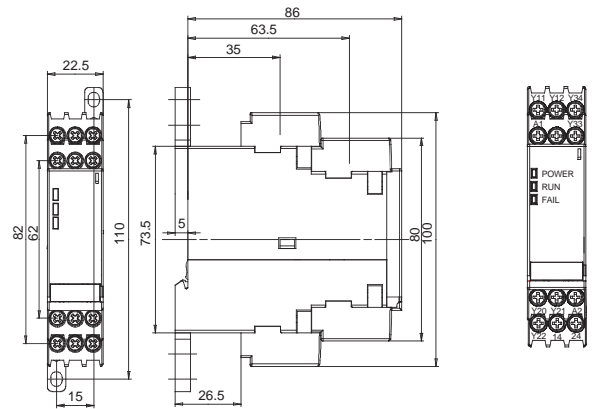

C565-S

